



TUALATIN VALLEY  
WATER DISTRICT

# Water System Design and Construction Standards

**Draft June 2024**

Conforms with TVWD Resolution 03-09 and TVWD Policies for Water System Standards as approved by the TVWD Board of Commissioners.

---

Paul L. Matthews  
Chief Executive Officer

---

Peter Boone, PE, PLS  
Chief Operating Officer

# Table of Contents

List of Tables .....	3
List of Standard Details .....	3
Definitions, Acronyms, and Abbreviations .....	4
<b>1 General Requirements .....</b>	<b>1-1</b>
1.1 Scope and Definitions .....	1-1
1.2 Procedures for Use of District Design Standards .....	1-1
1.3 General Process for Water System Improvements by Developer .....	1-1
1.4 Distribution System Material Selection .....	1-2
1.5 Preparation and Submittal of Engineering Plans .....	1-3
1.6 Approval of Engineering Plans .....	1-4
1.7 Construction Staking Requirements .....	1-4
1.8 Construction Inspection .....	1-5
1.9 Electronic Drawings .....	1-5
1.10 Requirements for Acceptance of Water System Improvements .....	1-5
1.11 Warranty .....	1-6
1.12 Easements .....	1-6
1.13 General Design Requirements .....	1-7
1.14 General Materials Requirements .....	1-7
1.15 General Construction Requirements .....	1-8
<b>2 Trench Excavation and Backfill .....</b>	<b>2-1</b>
2.1 General Requirements .....	2-1
2.2 Materials .....	2-1
2.3 Construction .....	2-2
<b>3 Water Mains .....</b>	<b>3-1</b>
3.1 General Requirements .....	3-1
3.2 Materials .....	3-4
3.3 Construction .....	3-10
<b>4 Valves and Valve Boxes .....</b>	<b>4-1</b>
4.1 General Requirements .....	4-1
4.2 Materials .....	4-2
4.3 Construction .....	4-6
<b>5 Fire Hydrants .....</b>	<b>5-1</b>
5.1 General Requirements .....	5-1
5.2 Materials .....	5-1
5.3 Construction .....	5-2
<b>6 Water Service Connections .....</b>	<b>6-1</b>
6.1 General Requirements .....	6-1
6.2 Materials .....	6-2

6.3	Construction.....	6-5
<b>7</b>	<b>Precast Concrete Vaults .....</b>	<b>7-1</b>
7.1	General Requirements.....	7-1
7.2	Materials .....	7-1
7.3	Construction.....	7-4
<b>8</b>	<b>Cross Connection Control Requirements.....</b>	<b>8-1</b>
8.1	General Requirements.....	8-1
8.2	Conditions Where Backflow Prevention is Required .....	8-1
8.3	Backflow Prevention Types and Hazards .....	8-2
8.4	Installation Requirements .....	8-3
<b>9</b>	<b>Corrosion Control.....</b>	<b>6</b>
9.1	General Requirements.....	6

DRAFT

## List of Tables

Table 1.1 Pipe Installation Guide .....	1-2
Table 3.1 Maximum Allowable Deflection of DI Pipe Restrained Joints (18-foot pipe length) 1, 2 .....	3-2
Table 3.2 Acceptable Tapping Sleeves .....	3-7
Table 3.3 Polyethylene Encasement Minimum Acceptable Values .....	3-9
Table 3.4 Hypochlorite Solution .....	3-18
Table 4.1 Minimum Number of Turns .....	4-3
Table 6.1 Required Meter Boxes and Covers .....	6-5
Table 6.2 Required Angle Meter Stops .....	6-5

## List of Standard Details

STANDARD DETAIL	TITLE
201	Typical Trench Backfill
301	Polyethylene Encasement Installation Method
302	Tapping Sleeve
303	Sample Station
304	Straddle Block For Ductile Iron Pipe
305	2" Blowoff Assembly at Normally Closed Pressure Zone Break
306	2" Standard Blowoff (4" – 8" Mainline)
307	Phase Break End for Future Extension (4" – 8" Mainline)
308	Phase Break End for Future Extension (12" Mainline)
309	Locate Station
310	Locate Station Closeup
311	Locate Station Placement
401	Typical Water Valve Location
402	Typical Valve Setting
403	Valve Operator Extension
404	2" Combination Air and Vacuum Valve with 1" Service
405	2" Combination Air & Vacuum Valve
501	Typical Water Main and Fire Hydrant Location
502	Fire Hydrant Standard Installation
503	Fire Hydrant Clear Zone
601	Water Service Connection: General Notes

602	Water Service Connection: Service Installation
603	Water Service Connection: Meter Box Placement in Planter Strip
604	Water Service Connection: Meter Box Placement Behind Sidewalk
605A	Water Service Connection: Meter Box Assembly
605B	Water Service Connection: Approved Meter Boxes and Covers
606	3" Meter Installation
607	4" Meter Installation
608	6" Meter Installation
609	8" Meter Installation
610	10" Meter Installation
701	Vault Ladder Installation
702	Electric Sump Pump Installation
703	Hydraulic Sump Pump Installation
801	Double Check Valve Assembly or Double Check Detector Assembly
802	Reduced Pressure Backflow Assembly (Above Ground)
803	Reduced Pressure Backflow Assembly (In Vault)
804	Minimum Protection for Filling Tanker Trucks

## Definitions, Acronyms, and Abbreviations

### Definitions

Contractor	The person or entity employed by the developer, owner, or district in order to implement water system improvements.
Developer	The person or entity legally responsible for the development of land.
District	The Tualatin Valley Water District.
District Engineer	The District's Chief Engineer, or their authorized representative.
Inspector	The person employed by the District to observe construction and enforce the District's Water System Standards and proper construction of water system improvements.
Installation Type	Based on the criticality as well as the size of a pipeline, the District requires that various measures be taken to protect a proposed pipe system. Refer to <a href="#">Table 1-1</a> for a guide to pipe material selections.
Owner	The person or entity who possesses legal ownership of the land affected by the improvements.
Project Engineer	The engineer in responsible charge of designing the water system improvements, who must be registered in the State of Oregon.
Resistivity	Resistivity is the electrical resistance of a unit volume of a material, the reciprocal of conductivity and is used to help determine soil corrosivity.

Rules and Regulations	Guidelines as adopted by ordinance by the Board of Commissioners to conduct safe, fair, and effective business with our customers.
Standard Details	Detail drawings showing specific installation details for water system components.
Standards	The Tualatin Valley Water District Water System Design and Construction Standards.

## Acronyms

Note: When references to the following capitalized abbreviations are made, they refer to Specifications, Standards, or Methods of the respective association or agency.

AASHTO	American Association of State Highway and Transportation Officials
ANSI	American National Standards Institute
APWA	American Public Works Association
ASTM	American Society for Testing and Materials
AWWA	American Water Works Association
DIPRA	Ductile Iron Pipe Research Association
ISO	International Organization for Standardization
NACE	NACE International (formerly National Association of Corrosion Engineers)
NSF	NSF International (formerly National Sanitation Foundation)
OAR	Oregon Administrative Rules
ODOT	Oregon Department of Transportation
OHA	Oregon Health Authority
ORS	Oregon Revised Statutes
OSHA	Occupational Safety and Health Administration
UL	Underwriter's Laboratories, Inc.
UPC	Uniform Plumbing Code

## Abbreviations

AVB	Atmospheric Vacuum Breaker	MIC	Microbiologically Induced Corrosion
BCR	Begin of Curb Return	MIPT	Male Iron Pipe Thread
CC	AWWA Taper Thread	MJ	Mechanical Joint (fitting)
CTS	Compression Connection	Ω-cm	Ohms-centimeters
DFT	Dry Film Thickness	OS&Y	Outside Stem/Screw and Yoke
DCDA	Double Check Detector Assembly	PRV	Pressure Reducing/Regulating Valve
DIP	Ductile Iron Pipe	psi	Pounds Per Square Inch (pressure)
ECR	End of Curb Return	PUE	Public Utility Easement
FIPT	Female Iron Pipe Thread	PVB	Pressure Vacuum Breaker
ft-lb	Foot-Pound	PVC	Polyvinyl Chloride Pressure
fps	Feet Per Second	RP	Reduced Pressure Valve Assembly
g/m <sup>2</sup>	Grams per Meter Squared	RPDA	Reduced Pressure Detector Assembly
HDPE	High Density Polyethylene	SDR	Standard Dimension Ratio
in	Inch	SSSP	Site-Specific Safety Plan
lbs	Pounds	SVB	Spill-Resistant Vacuum Breaker
LLDPE	Linear Low-Density Polyethylene	V/MIL	Volt per Mil
mg/L	Milligrams per Liter	WSP	Working Steam Pressure
mils	Thousandths of an Inch		

# 1 General Requirements

## 1.1 Scope and Definitions

- A. These Standards include provisions, technical specifications, and requirements for construction within the Tualatin Valley Water District, and other entities managed by the District.
- B. In addition to following these Standards, water system design and construction shall abide by all relevant codes, ordinances, and regulations. In cases of conflicting requirements, the more stringent standard shall apply.
- C. Standard Details are included in this set of Standards to supplement the written standards. In the event of a conflict between the Standards and the Standard Details, the District Engineer shall decide which standard shall have precedence. Generally, the Standards shall have precedence.
- D. The District Engineer has the authority to recommend or allow deviations from these Standards in necessary circumstances, according to their best judgment.
- E. Public health and safety shall be protected in the Project Engineer's designs, and at all times during construction of water system improvements.
- F. All construction and other water system related work shall be performed, following all applicable rules and regulations, by experienced workers using tools in good repair to a high quality of workmanship.
- G. The District may revise these Standards at any time without prior notification. Any amendment shall take effect upon the date indicated in the addendum upon posting to the District's website.

## 1.2 Procedures for Use of District Design Standards

- A. The primary purpose of the Standards is to provide direction to Developers on District requirements for new potable water distribution infrastructure. These Standards may also be used to provide direction to consulting engineers hired by the District to design other water main projects.

## 1.3 General Process for Water System Improvements by Developer

- A. In general, the process for designing and installing water system improvements shall be as follows:
  - 1. The District recommends the Project Engineer contact the District Engineer prior to initiating the project design. The District Engineer may suggest or require a pre-design meeting to discuss the specific requirements for the project.
  - 2. The Project Engineer shall determine pipe material selections in accordance with [Section 1.4](#).
  - 3. The Developer shall submit engineering plans prepared by the Project Engineer and sealed with a professional engineer's stamp in accordance with ORS 672, along with the plan review fee. Refer to [Section 1.5](#) for plan submittal requirements.



4. The District shall review the engineering plans for conformance with the Standards. Deviations from the Standards may be requested but will require specific approval at the sole discretion of the District Engineer. If changes and revisions are required following District review, the Project Engineer shall revise and resubmit the plans.
5. Following approval of the plans by the District, the Contractor shall install the improvements in accordance with the approved plans.
6. The Inspector shall monitor and inspect the work throughout construction to ensure compliance with the approved plans and the Standards.
7. The Contractor shall notify the Inspector in writing or by phone when the project, or designated portion of the project, is substantially complete. The Inspector will conduct a walkthrough with the Developer, the Developer's Project Engineer, and the Contractor to inspect the substantially completed work. The Inspector will prepare and submit to the Contractor a punch list of items to be completed or corrected based on the results of the final walkthrough. The Contractor shall take immediate steps to remedy the listed deficiencies and notify the District in writing when the project is complete and ready for final inspection. The Inspector will make a final inspection and, if the work is considered to have reached final completion with all punch list items remedied, will notify the Contractor in writing that the work has been accepted by the District.
8. Upon completion of the work, the Developer shall submit to the District Electronic Drawings prepared by the Project Engineer as described in [Section 1.9](#).
9. After final acceptance by the District, the Developer shall provide a one-year warranty on the improvements.

## 1.4 Distribution System Material Selection

- A. Table 1-1 shall be used as a guide to pipe material selections. The District Engineer will determine if any pipelines within a project shall be deemed to be critical.

Table 1.1 Pipe Installation Guide	
Level of Service & Size	Pipe Material Type & External Coating
Noncritical and ≤ 12" Diameter	Ductile iron pipe and fittings with zinc coating and polyethylene encasement
Critical Pipes or > 12" Diameter	Preliminary design report required per <a href="#">Section 9</a> to analyze and recommend pipeline materials and appropriate corrosion protection measures

- B. Critical, or larger diameter pipelines, will require soil resistivity testing, in accordance with Sections [1.5.H.5](#) and [9.1](#), and implementation of corrosion protection measures.
- C. Requirements for trench excavation, bedding, backfill, and restoration for all pipe types are provided in [Section 2](#) of these Standards. Requirements for ductile iron pipe, fittings, and polyethylene encasement are provided in [Section 3](#) of these Standards.

## 1.5 Preparation and Submittal of Engineering Plans

- A. All plans for water system improvements must be prepared and sealed by a Project Engineer who is licensed by the state of Oregon and shall comply with all applicable sections of OAR 333-61.
- B. Submit plan review fee and engineering plans in Portable Document Format (PDF) to the District Engineer for review and approval. Engineering plans shall be full set including all roadway and utility improvements.
- C. If the project will be completed in more than one phase, the extents of each phase must be clearly indicated on the plans.
- D. If modifications to the project are made after the District has reviewed and approved the plans, a full resubmittal of engineering plans showing the revisions will be required.
- E. Minimum text height shall be 0.10-inch.
- F. Plans shall include a cover sheet with the following information:
  - 1. Project name.
  - 2. Owner's name, address, phone number, and email address.
  - 3. Project Engineer's name, address, phone number, and email address.
  - 4. Contractor's name, address, phone number, and email address, if available.
  - 5. Project location (Vicinity Map).
- G. Generally, engineering plans shall include the following information:
  - 1. Existing and proposed utilities (water, sewer, storm, power, gas, telecommunication, cable, poles, etc.) on a composite utilities sheet.
  - 2. Existing and proposed water utilities sheet, separate from the composite utilities sheet.
  - 3. Existing and proposed curbs, sidewalks, driveways, mailboxes, trees, light poles, and other street features.
  - 4. Existing and proposed right-of-way and easements, including those required for water improvements.
  - 5. Horizontal and vertical alignments of proposed public water mains.
  - 6. Location of soil resistivity tests, if necessary, and resulting field measurements to justify pipeline installation type.
  - 7. Size, material, and location of proposed and existing water mains and services.
  - 8. Size, type, and location of proposed and existing water appurtenances, including but not limited to:
    - a. Valves and Air Release Valves
    - b. Hydrants
    - c. Fittings (Bends, Tees, Crosses, Reducers)
    - d. Pressure Regulators
    - e. Vaults

- f. Meters
  - g. Cathodic Protection Test Stations
  - h. Anodes
  - i. Phase breaks including temporary blow offs
  - j. Locate Stations
  - k. Thrust blocks
9. Joint restraint requirements.
10. District Standard Details that are applicable to the project.
- H. If applicable, include drawings showing:
- 1. Landscaping plans showing the layout of irrigation systems, backflow device(s), and any decorative water features.
  - 2. Mechanical plans of boilers, chillers, and other water-consuming mechanical devices.
  - 3. Plumbing plans with locations of on-site backflow devices; fire line drawings showing plans of antifreeze (either potable or non-potable) loops, etc.

## 1.6 Approval of Engineering Plans

- A. The District Engineer's approval of the project or development plans is required prior to the start of any construction. Plan approvals are only valid for six months from the date of approval, after which time drawings must be resubmitted, and plan review resubmittal fee must be paid prior to approval.
- B. Any changes to approved plans initiated by the Project Engineer or resulting from field conditions must be resubmitted and approved by the District Engineer.
- C. The Developer or their agent shall obtain all required permits from all applicable jurisdictions.
- D. Any property to be developed that is not currently within the District boundary shall be annexed into the District prior to extending water service to the site, unless an extra-territorial water line extension has been approved.

## 1.7 Construction Staking Requirements

- A. Construction staking is required for all water system improvements. Staking shall be performed by or under the supervision of an Oregon Registered Professional Land Surveyor or Registered Professional Engineer.
- B. Staking shall be in place prior to installation of water system improvements. Staking shall be preserved and shall not be disturbed until the Inspector authorizes it to be removed. If staking is disturbed or removed prior to the Inspector's approval, it shall be promptly replaced.
- C. Line and grade stakes for water mains shall be provided on an offset line at intervals not exceeding 50 feet. Offset distance shall not be greater than 20 feet. Stakes shall be marked with stationing as well as elevation references (cut/fill) to finished grade and to top of pipe.

- D. The locations of taps, valves, fittings, hydrants, water meters, and other appurtenances shall be staked with offset stakes. Hydrant and meter stakes shall be marked with elevation references (cut/fill) to top of curb or to finished grade if no curb will be installed. Meter stakes shall be marked with lot numbers.

## 1.8 Construction Inspection

- A. The Contractor shall contact the Inspector at least 48 hours prior to any water system construction to request a pre-construction conference and pay the inspection fee.
- B. The District Engineer and Inspector shall have access to the project at all times in order to make routine visual inspections of the work.
- C. No work shall be buried before it is inspected and accepted by the Inspector. Potholing of buried water lines may be required at the Developer's expense to allow verification that the installation meets the requirements of the Standards.
- D. Should any inspection reveal that construction is not proceeding according to the approved plans and/or the Standards, the District Engineer or Inspector may order all work stopped and all defective work removed and replaced. If a revision is necessary, the Project Engineer shall provide the District Engineer with revised plans for review and approval before work resumes.
- E. Work by Contractor outside of the District's normal business hours shall require a minimum of 48 hours' notice to Inspector. Overtime costs for District inspection will be paid by the Contractor.

## 1.9 Electronic Drawings

- A. Upon completion of the project, the Project Engineer shall submit an electronic file of the final as-built drawings for the project, clearly showing changes from the approved plans which includes as-built waterline and appurtenance locations, and all property lines, street right of way lines and lot numbers. The District will review "as-built" drawings of the water facilities based on Inspector documentation collected during construction.
- B. Electronic files shall be submitted to the District Engineer via email as an attached file in PDF and in AUTOCAD.DWG or .DXF format. Verify the appropriate format version with the District Engineer prior to submittal.
- C. Submittal of "as-built" drawings may be waived as determined by the District Engineer.

## 1.10 Requirements for Acceptance of Water System Improvements

- A. The following items must be completed and / or submitted to District Engineer prior to final acceptance of water system improvements:
  1. Compliance with all relevant Standards, including but not limited to standards for design, construction, disinfection, pressure testing, bacteriological testing, and cathodic protection electrical continuity testing (if applicable).
  2. Completion of final lift of paving, ensuring that all valve boxes are raised and flush with the surface.
  3. Request for final inspection and correction of any punch list item deficiencies identified by District staff at the final inspection walk-through.

4. Submission of electronic files for the project, as described in [Section 1.9](#).
5. Provide documentation that any required easements and/or right-of-way dedications have been completed and recorded.
6. The District reserves the right to withhold installation of water meters until the project has been granted final acceptance.
7. The District may approve the installation of water meters and irrigation water meters, provided by the District, prior to final acceptance if the following conditions are met:
  - a. A performance bond in the amount of remaining waterline work as determined by the District, or a minimum of \$10,000, is submitted to the District prior to release of the subdivision for water meter installation. This includes payment of the bond processing fee.
  - b. All necessary backflow prevention devices have been installed, tested, and certified as described in [Section 8](#) of these Standards.

## 1.11 Warranty

- A. A one-year warranty period shall be provided for the water system improvements by the entity responsible for performing the work to guarantee to District that all work will be in accordance with the District approved plans and the Standards and will not be defective. Any failure of materials or workmanship during the warranty shall be repaired or replaced to the District's satisfaction at the expense of the entity responsible for performing the work.
- B. The warranty period shall begin on the date of final written acceptance of the project by the District.
- C. Water system materials shall be installed within manufacturer's warranty period, not less than 1-year remaining on the warranty, and no more than 3-years beyond the manufactured date.

## 1.12 Easements

- A. Where it is not practical or possible to install water system improvements within a dedicated public right-of-way or public utility easement, the District may allow the improvements to be installed within a dedicated easement on private property.
- B. Water line easements shall be centered on the pipe. Minimum easement widths shall be 15 feet for areas adjacent to public right of way with vehicular access (roadways, parking lots, etc.) and 20 feet for areas without vehicular access. Additional width may be required for special circumstances such as slopes, transmission pipelines, or other cases as determined by the District.
- C. Easements for vaults or other water system appurtenances shall extend a minimum of 5 feet on all sides of the structure. Additional width may be required for special circumstances such as slopes or other cases as determined by the District.
- D. Easements granted to the District shall allow for access, construction, operations, maintenance, replacement, reconstruction, and removal of the water system improvements, including the right to remove, cut and trim trees, brush, overhanging branches, and remove structures and other obstructions as necessary for the permitted use of the easement.

- E. If access to the easement area and associated appurtenances is not directly available from a public right-of-way, an access easement along the most direct route of access shall be granted to the District.
- F. Easement exhibits shall be prepared by a Professional Land Surveyor. Easement dimensions and language shall be subject to final approval by the District. Easements shall be recorded prior to final project acceptance.

## 1.13 General Design Requirements

- A. Potholing of existing facilities, either those owned by the District or other utilities, shall occur during the design phase for any location where the vertical and/or horizontal location will significantly impact construction of the new facilities. Locations and results of potholing on existing facilities shall be clearly indicated on design plans for District review. The District Engineer may determine that additional potholing is required prior to plan acceptance. The District Engineer or Inspector shall be present on site during potholing operations, unless prior approval is granted.
- B. Any permanent appurtenance that is above the sidewalk elevation and/or finish grade shall be at least 18 inches behind the sidewalk. Access to meters requires six feet vertical clearance above the meter box and two feet clearance around. A clear space shall be maintained around fire hydrants, fire protection equipment, and control valves. Refer to Standard Detail 503 as well as the District Rules and Regulations for a full description of access and clear space requirements.
- C. In locations outside of the established right-of-way, mark water line appurtenances, such as valves, blow off assemblies, and cathodic protection test stations with a Carsonite marking post, or District approved equal. Post shall be blue in color, a minimum width of 3.5 inches, and be set with the top of post three feet above finished grade and offset from the appurtenance to allow for operation of the appurtenance.
- D. Distribution system pressure:
  - 1. District practice is to provide water service at a minimum pressure of 40 pounds per square inch (psi). Available pressure at specific locations may fall below this value depending on geographic features within a particular pressure zone.
  - 2. Where the pressure exceeds 80 psi, the District may require Developers to install a pressure reducing facility such as a vault housing pressure reducing valves (PRVs) on the water main. Refer to the Uniform Plumbing Code for requirements regarding individual pressure regulating devices on each service line on the customer's side of the meter.

## 1.14 General Materials Requirements

- A. Only materials designed for potable water service and meeting NSF 61, AWWA standards, and other applicable standards shall be used in those elements of the water system which may come in contact with potable water. All materials must be certified "lead-free".
- B. All materials used for water system construction shall be of new manufacture. No rebuilt, reconditioned, or previously used materials shall be allowed.
- C. Throughout these Standards, specific materials or equipment are specified or described by using the name of a proprietary item or supplier to establish the type, function, appearance, and quality required. Unless the description is followed by language to

indicate that no substitutes will be acceptable, substitute products may be submitted for approval at the sole discretion of the District Engineer, under the following circumstances:

1. The product is equal in materials of construction, quality, durability, longevity, appearance, strength, and design characteristics.
2. The product will reliably perform at least equally well in function and achieve the results imposed by the District specified item.
3. The product manufacturer has a proven record of performance and availability of responsive service.
4. There will be no increase in life-cycle costs to the District for purchasing replacements, repairs, or maintenance.
5. The District is provided sufficient information including samples, materials of construction, design characteristics, and history of proven performance to adequately review the merits of the product.
6. The District is allowed a reasonable time within which to evaluate each substitute product proposal and sufficient information is provided to determine that the proposed product is an equal. The District may request additional data on the proposed item and may require a special performance guarantee or other surety.

## 1.15 General Construction Requirements

### A. Safety and Worksite Conditions

1. Project safety shall be the responsibility of the Contractor. Prior to beginning work on the project, the Contractor must assess potential hazards that will be encountered while performing the contracted work and develop a Site Specific Safety Plan (SSSP). The plan must include the procedures and methods for eliminating or controlling the project-specific safety hazards identified. This does not have to be a written plan. However, the Contractor must be able to articulate the SSSP to the Inspector during the pre-construction meeting.
2. Contractor shall inform the Inspector of the specific requirements of Contractor's SSSP that the Inspector and other District representatives must comply with while at the site.
3. Contractor is responsible for and shall conduct their operations in a manner ensuring safe working conditions at all times for all employees, public, and all others who may come in contact with, or may be exposed to, any operations related to the project. Compliance with the requirements of these provisions will not relieve the Contractor of the obligations assumed by the Contractor as required by law.
4. Contractors shall abide by all Oregon Occupational Safety and Health Administration (OSHA) and other applicable safety regulations. Contractor shall comply with Contractor's SSSP for the health and safety of persons and property in the vicinity of the work area. Noncompliance by Contractor or its employees with the SSSP or regulatory requirements is grounds for a stop work order. Contractor bears sole responsibility for penalties imposed for noncompliance.
5. Contractors shall provide and maintain sanitary facilities for employees in accordance with applicable regulations. Contractor shall ensure all work sites and

areas are maintained free of recognized hazards and in a sanitary and organized state.

6. The Contractor shall clean all spilled dirt, gravel, or other foreign material caused by construction operations from all streets and walkways at the end of each day's operation and shall adhere to all applicable erosion control requirements.
7. Contractors shall follow Oregon Safe Dig laws and standards (OAR 952-001).
8. Contractor shall ensure that workers arrive at the jobsite fit for duty, which includes being physically able to work, rested, and not under the influence of alcohol or drugs.
9. All safety-related equipment installed for use by the Contractor shall be made available to the Inspector for completion of required duties (e.g., inspections, testing, observations). This includes but is not limited to, sanitation facilities, access and egress points, anchorages, guardrail systems, scaffolds, ventilation, rescue systems, shade systems, parking, electrical facilities, and artificial lighting.

#### B. Permits and Road Closures

1. The Contractor or Developer shall obtain the appropriate utility permit(s) from the city, state, or county with jurisdiction for the streets or roads within the project work area prior to construction of system improvements.
2. Contractors shall comply with all rules and regulations of the applicable city, state, and county authorities regarding the closing of public streets or highways to use of public traffic. No road shall be closed to the public, except by express permission of the affected regulating authority.

#### C. Valve Operation Prohibited

1. Operation of valves in the District's water system by anyone other than District employees is strictly prohibited. Contractors shall not open or close valves or take any other action that may affect the operation of the existing water system, except as specifically required by the plans and specifications, and only with prior approval by the District.
2. The Contractor shall notify the District at least 48 hours in advance to request valve operation and/or interruption of the existing service.

#### D. Interruption of Utility Service

1. In the event of accidental interruption of domestic water service, the responsible party shall immediately notify the Inspector or District at 503-848-3000.
2. The responsible party shall arrange for restoration of service as promptly as possible and bear all costs of repair. In no case shall interruption of any water service be allowed outside of working hours, unless prior approval is granted by the District.
3. The Contractor shall provide a written shutdown plan a minimum of two (2) weeks prior to any planned shutdown or interruption of utility service. The shutdown plan shall provide details of the sequence, timing, duration, and work activities planned during the shutdown period. The plan shall include a dewatering plan for the existing pipe and trench. No water from the ditch shall be allowed to enter the pipe. The District Engineer shall have sole discretion for approval of the shutdown plan.
4. Planned shutdowns shall be limited to a maximum duration of four (4) hours and shall only occur on Tuesdays, Wednesdays, and Thursdays. Shutdowns during the week of a federal holiday are not permitted unless approved by District Engineer.



- E. Damage to Water System during Construction
  - 1. The District shall be notified immediately if any part of the water system is damaged in any way.
  - 2. Repair of any damage to the District's facilities caused by a Contractor shall be made to the Standards at the Contractor's expense. The District, at its option, may make the repairs and bill the Contractor on a time and materials basis.
- F. Relocation of Existing Mains
  - 1. Any water line or water meter relocation work that is a requirement of the development shall be performed by District crews at the Developer's expense on a time and materials basis unless otherwise authorized by the District. A deposit for the estimated cost of the work is required prior to planning and commencing the work.
  - 2. Abandonment or removal of existing facilities shall occur as close to the main as possible. Where abandoned facilities connect to the main with a saddle tap, the saddle shall be removed, and a repair clamp installed. See [Section 3.2](#) for repair clamp requirements for abandoning water main connections. Where abandoned facilities connect to the main with a valve, the valve shall be removed, and the fitting plugged or capped.
- G. Water Service Installation
  - 1. Installation of service lines 2 inches in diameter or smaller on new portions of the water system shall be performed by the Contractor.
  - 2. Installation, relocation, reconnection, or abandonment of service lines 2 inches in diameter or smaller on the live water system shall only be performed by District crews unless otherwise directed by the District.
- H. Connections to the Water System
  - 1. Connections to existing mains for proposed mains or services larger than 2 inches in diameter shall be wet-tapped by a tapping contractor using proper equipment, unless otherwise instructed by the District Engineer. Connection to the system shall be done in the presence of the Inspector. Qualifications for the proposed tapping contractor, along with a detailed description of the tapping method and connection plan shall be submitted to the District for review and approval prior to commencing work.
  - 2. Contractor shall notify the Inspector at least 48 hours prior to beginning installation, relocation, or abandonment of service lines.
- I. Preservation of Land Survey Monuments
  - 1. The Contractor shall preserve all existing survey monuments in and around the work area. If any survey monument will be disturbed by construction, it is the responsibility of the Developer or Contractor to hire a Professional Land Surveyor licensed in the State of Oregon to conduct a pre-construction survey and replace the affected monuments in accordance with state laws.
- J. Preservation/Replacement of Existing Structures
  - 1. Contractor shall preserve, repair, or replace all existing structures damaged during construction, including but not limited to storm sewers, catch basins, and culverts.

K. Contractor Pre-qualifications/Training & Certifications

1. Cathodic protection systems if required (anodes, joint bonds, test stations, etc.) shall be designed, constructed, and inspected only by those who meet the qualification requirements specified in [Section 9](#).

DRAFT

# 2 Trench Excavation and Backfill

## 2.1 General Requirements

### A. Types of Allowed Backfill

1. Class A backfill – compacted native material
  - a. Class A backfill requires District approval and shall only be considered for use in unpaved areas. Class A backfill is not allowed within the pipe zone.
2. Class B backfill – compacted crushed rock granular material
  - a. Class B backfill shall be used in all paved areas.
3. Refer to Standard Detail 201.

## 2.2 Materials

### A. Class A Backfill – compacted native material

1. The District may require a geotechnical engineering investigation of the suitability of native materials for use in trench backfill.
2. Class A backfill material shall be select material from the trench excavations with all foreign material, debris, and rocks larger than 1-inch diameter removed.
3. The moisture content of Class A backfill material shall be no more than 5% above optimum during backfill placement and compaction.

### B. Class B Backfill – compacted crushed rock granular material

1. Class B backfill material shall be crushed rock meeting the requirements of ODOT Standard Specifications Section 00641 and Section 02630.
2. Designated sizes shall be 1" - 0" or ¾" - 0" with no more than 10% passing the No. 200 sieve (wet analysis).

### C. Bedding and Pipe Zone Material

1. Bedding and pipe zone material shall be Class B backfill material.

### D. Foundation Stabilization Material

1. Foundation stabilization material shall be 2 ½" - 0" crushed rock meeting the requirements of ODOT Standard Specifications Section 00641 and Section 02630, or other material as approved by the District Engineer.

### E. Geotextile Fabric Material

1. Geotextile fabric shall be a nonwoven polypropylene fabric such as Mirafi 140N as manufactured by TenCate, or District approved equal.

### F. Ballast Concrete

1. Ballast concrete may be required in areas where trench excavation extends below the localized groundwater elevation. Specific conditions will be evaluated on a case-by-case basis. The Contractor shall submit the concrete mix design and proposed installation methods to the District for approval.

## 2.3 Construction

### A. Pavement, Curb, and Sidewalk Removal

1. Prior to excavation of the trenches, cut all pavements, curbs, and sidewalks, regardless of the thickness, with a pavement saw or other approved pavement cutter.
2. The width of the pavement cut shall be at least equal to the required width of the trench at ground surface. The city, county, or state agency responsible for the street may require T-cutting or additional pavement milling prior to re-surfacing.
3. Removed pavement and concrete materials shall be hauled from the site to be recycled and not used for trench backfill.

### B. Trench Width, Base, and Grade

1. All trench excavation shall be sufficient to provide a minimum of 36 inches of cover over the top of the installed water main.
2. Trench excavations where pipe is to be laid shall be sufficient to provide a minimum width of 12 inches greater than the nominal diameter of the pipe, or 24 inches, whichever is greater, unless otherwise approved by the District Engineer.
3. Grade the full width of the bottom of the trench where the pipe is to be laid; additional excavation to accommodate pipe bells is required. The trench bottom shall be level across the width and on a uniform grade between grade breaks along the length of the trench.
4. Foundation Stabilization
  - a. When the existing material in the bottom of the trench is unsuitable for supporting the pipe, excavate below the bottom of the pipe zone. Backfill the trench to the bottom of the pipe zone with approved material and compact to 95% max density. If firm, native material is not present within three feet below the bottom of the pipe zone, contact the Inspector for further guidance on foundation stabilization.

### C. Shoring, Sheeting, and Bracing of Trenches

1. Trench safety, including but not limited to shoring and bracing design, shall be the responsibility of the Contractor.
2. Erect, maintain, and remove shoring, sheeting and bracing as required by the most stringent of all applicable laws, codes, and ordinances.
3. Where sheeting and bracing are used, increase trench widths accordingly by the thickness of the sheeting. Keep sheeting in place until the pipe has been placed and backfilled at the pipe zone.
4. Shoring and sheeting shall be removed as backfilling progresses in a manner that will not damage the pipe or permit voids in the backfill.

### D. Location of Excavated Materials

1. During trench excavation, place the excavated material within the construction easement or specified working area so that the excavated material does not obstruct any private or publicly traveled roadways.

2. Pile material away from trenches so that the toe of the slope of the material excavated is at least 36 inches from the edge of the trench.
  3. It shall be the Contractor's responsibility to determine the safe loading of all trenches with excavated material.
- E. Removal of Water
1. Provide ample means by which to promptly remove and dispose of all water entering the trench for all phases of construction until completion of backfill of the pipe zone. These provisions shall apply during working and non-working hours.
  2. Control groundwater to prevent softening of the bottom of excavations or formation of "quick" conditions or "boils". Design and operate the dewatering systems to prevent removal of the natural soils so the groundwater level outside the excavation is not reduced to the extent that would damage or endanger adjacent structures or property.
  3. Drainage of trench water through the pipe under construction is strictly prohibited.
  4. The pipe shall be plugged during construction and storage so that no groundwater or other foreign material may enter at any time. See [Section 3.3.A](#) for pipe plug requirements.
  5. Disposal of water from dewatering operation and flushing shall be the responsibility of the Contractor. Any applicable permits shall be obtained by the Contractor and strictly followed.
- F. Addition and Compaction of Backfill
1. Bedding and Pipe Zone
    - a. Bedding shall be at least six inches in depth below the bottom of the pipe and shall extend across the full width of the trench.
    - b. The pipe zone shall extend from six inches below the bottom of the pipe to twelve inches above the top of the pipe barrel. The pipe zone material shall extend across the full width of the trench.
    - c. After the pipe is in place, backfill the pipe zone at an even rate such that there is an even layer of backfill on either side of the pipe at all times.
    - d. Compact the pipe zone by tamping in eight-inch lifts. Each layer shall be compacted to at least 95% of its maximum density as determined by AASHTO T-99. No unfilled or un-compacted areas shall exist beneath the pipe.
    - e. Refer to Standard Detail 201.
  2. Class A Backfill
    - a. Place approved material in the trench above the pipe zone in lifts not exceeding 18 inches, loose measure.
    - b. Compact each layer by mechanical methods to 90% maximum density as determined by AASHTO T-99.
    - c. Mound backfill material to several inches above finished grade to account for minor settlement.

3. Class B Backfill
  - a. Place approved material in the trench above the pipe zone in lifts not exceeding 8 inches.
  - b. Compact each layer by mechanical methods to 95% maximum density as determined by AASHTO T-99.
  - c. Backfill trench to subgrade elevation and construct or re-construct the street structural section per applicable jurisdiction's requirements.
4. Under no circumstances shall the Contractor allow sharp, heavy pieces of material to drop directly onto the pipe or the tamped material around the pipe. Special care shall be taken to protect polyethylene encasement.
5. When placing and compacting pipe zone and backfill material, the Contractor shall exercise extreme caution to prevent damage to polyethylene encasement.
6. The agency having jurisdiction over the right-of-way (county, city, state) may have additional requirements or more stringent standards relating to trench backfill within the right-of-way. In these cases, the Contractor shall perform the work in accordance with the more stringent standard and notify the Inspector of the discrepancy.
7. Settlement
  - a. Any settlement noted in trench backfill, finished surfacing, or structures built over the surfacing during the warranty period will be considered to be caused by improper compaction methods.
  - b. The Contractor shall correct settlement and restore any structures damaged by settlement to their original condition, or as required by road owner, at no additional cost to the District.

#### G. Compaction Testing

1. The Contractor shall be responsible for the cost of all testing and shall submit a statement of qualifications for a qualified and independent testing laboratory or testing service, including ODOT certifications for density technicians. Approval of the testing laboratory or service shall be at the sole discretion of the District Engineer.
2. Testing of backfill compaction shall include a test at the surface and at 1.5-foot increments below the surface. Testing shall be conducted every 200 feet along the trench length or as directed by the District Engineer.
3. Field compaction test results shall be evaluated based on a standard Proctor (ASTM D698) laboratory test completed on a representative sample of the material being used as trench backfill.
4. The Contractor shall provide the test results to the Inspector. If results indicate that compaction or moisture content is inadequate, backfill material shall be removed and replaced prior to continuation of work.
5. Any trench backfill not passing the compaction test and/or showing visible failure shall be rejected and replaced.

## H. General Surface Restoration Specifications

### 1. Asphalt Concrete and Portland Cement Concrete Paving

- a. Asphalt concrete and/or Portland cement concrete pavement materials and installation shall conform to the current specifications and standards of the city, county, state or other agency having jurisdiction for the location where the work is to be performed.
- b. It is the responsibility of the paving contractor to confirm which agencies have jurisdiction as well as the current surface restoration requirements of each agency.
- c. Any pavement markings within the work area that are damaged or removed as a result of the work shall be repaired or replaced.

### 2. Protection of Structures

- a. Provide whatever measures may be needed to protect the exposed portions of the bridges, culverts, curbs, gutters, posts, guard fences, road signs, and other features from splashing oil and asphalt from the paving operations. After paving is complete, remove any oil, asphalt, or dirt that is left behind on these features as a result of the paving operations.
- b. Where water valve boxes, manholes, catch basins, or other underground utility appurtenances are within the area to be surfaced, the resurfacing shall be level with the top of the existing finished elevation of these facilities. If it is evident that these facilities are not in accordance with the proposed finished surface, notify the proper authority in order to have the facility altered before proceeding with the resurfacing around the obstruction, unless otherwise approved. Protect all covers during asphalt application.

### 3. Warranty Period

- a. Contractor shall provide a warranty period of no less than one (1) year on pavement. During this period the Contractor shall repair or replace, at no additional cost to the District, any pavement failure caused by defective material, installation, or compaction. The warranty period shall begin at the time the project is accepted by the District.

# 3 Water Mains

## 3.1 General Requirements

### A. Pipe Sizes

1. The minimum standard main size shall be eight inches unless otherwise approved.
2. Four-inch mains may be permitted when ALL the following conditions are met:
  - a. The run is less than 300 feet.
  - b. There are no more than eight services.
  - c. There is no possibility of a future main extension.
  - d. There is no requirement for a fire hydrant.
3. Fire hydrants shall not be connected to mains less than eight inches in diameter.
4. The District may require mains to be upsized to serve future development.
5. The District may require existing District-owned mains to be upsized to serve proposed development.
6. The District will make the final determination on the size of proposed mains.
7. 10-inch and 14-inch pipe sizes are not allowed within the District.
8. Any hydraulic calculations that justify pipeline sizing shall be made using a Hazen-Williams "C" coefficient of 120.

### B. Vertical Alignment

1. The pipe cover from the top of the pipe to the finish grade above the pipe shall be a minimum of 36 inches unless otherwise approved or required by the District Engineer. All reasonable effort should be taken to maintain 36 inches of cover. Any deviation from this standard depth shall be approved in advance by the District. For installations where at least 30 inches of cover cannot be maintained, a waiver must be granted by the state in accordance with OAR 333-61-0050.
2. The minimum vertical separation between water mains and other utilities (excluding sanitary sewer) is 12 inches. Vertical separation between water main and sanitary sewer shall conform with Oregon Administrative Rule 333-061-0050(9) and shall maintain a minimum of 18 inches unless otherwise approved.
3. Water main vertical alignment shall be designed to minimize high points where possible without resulting in excessively deep pipe installations.
4. See [Section 4.1.C](#) for air and vacuum release valve locations.
5. At stream crossings the minimum cover above the top of the pipe shall be five feet to the bottom of the stream bed.

### C. Horizontal Alignment

1. Water mains shall generally be located within the public right-of-way or in approved easements.
2. Water mains shall generally be located on the south and east sides of the street, six feet from the face of curb to the pipe centerline. Refer to Standard Detail 501.



3. Water mains along looped or curved streets shall not switch sides of the street.
  4. Water mains in streets with development along only one side of the street shall be placed six feet from the face of the curb adjacent to the lots served. This minimizes service line length and avoids "long-side" connections to fire hydrants.
  5. When it is not possible to install the main within a public right-of-way, the District may allow the main to be installed within an easement. See Section 1.12 for easement requirements.
  6. Water mains shall be spaced 10-feet minimum from sanitary sewers per OAR 333-61-0050. Refer to OAR requirements for additional spacing requirements where 10-foot minimum cannot be met.
  7. Water mains shall be spaced 5 feet minimum from other utilities unless otherwise approved by the District.
- D. Changes in Pipe Alignment
1. Generally, the District encourages the use of deflected pipe joints in lieu of bend fittings.
  2. Wherever it is necessary to deflect pipe from a straight line either in a vertical or horizontal plane, or where long radius curves are permitted, the amount of deflection allowed shall not exceed the values in Table 3.1 or fifty percent of the value recommended by the pipe manufacturer, whichever is less.

**Table 3.1 Maximum Allowable Deflection of DI Pipe Restrained Joints (18-foot pipe length) 1, 2**

Pipe Diameter (in)	Mechanical Joint Maximum Deflection <sup>3</sup>		Push-On Joint Maximum Deflection	
	Angle (degrees)	Offset per 18-foot pipe length (in)	Angle (degrees)	Length Offset per 18-foot pipe length (in)
4	8	31	2.5	9
6	7	27	2.5	9
8	5	20	2.5	9
12	5	20	2.5	9

<sup>1</sup> The maximum deflection shall be determined from Table 3-1 or 50% of the deflection recommended by the manufacturer, whichever is less.

<sup>2</sup> Safe deflection for 150 psi pressure. For higher pressure, reduce tabulated deflection 10 percent for each 10 psi added pressure and confirm allowable deflection with Inspector.

<sup>3</sup> This refers to the allowable joint deflection of the pipe within a ductile iron mechanical joint fitting, such as a bend, tee, valve, etc.

E. Dead-end Mains

1. Dead-end mains generally are not allowed.

2. If future extension of the street is anticipated, a line-size valve and two-inch blowoff assembly shall be installed at the end of the dead-end line. See Standard Detail 307 for phase break blowoff detail.
3. If future extension is not anticipated, or where required by the District, a mechanical joint cap and two-inch standard blowoff assembly shall be installed. See Standard Detail 306 for two-inch standard blowoff detail.
4. If a dead-end main is located in a cul-de-sac or future extension is not anticipated, and the end of the main is also located at a high point, then a combination air and vacuum valve assembly is also required.
5. Blowoff assemblies are required on each side of a normally closed valve as determined by the District Engineer per Standard Detail 305.
6. At the discretion of the District, a hydrant may be installed in lieu of a blowoff assembly on eight-inch or larger mains where a future extension is not anticipated.
7. If future extension of the street is anticipated, dead-end mains shall be extended to within five feet of the edge of pavement per Standard Detail 307. Valves must be accessible and shall not be blocked by street barricades.

#### F. Restrained Joints

1. All joints on water mains shall be restrained.
2. Thrust restraint shall be provided by restrained joints that meet the requirements specified in [Section 3.2. In cases where restrained joints are not feasible, thrust blocking may only be used with prior authorization from the District Engineer.](#)
3. Thrust blocks shall be used as thrust restraint at hot tap locations. See Standard Detail 302 for Tapping Saddle installation. Size and bearing area of thrust blocks is dependent on site-specific soils and other factors. The Project Engineer shall provide stamped design calculations for thrust blocks on all pipes larger than 8 inches in diameter.
4. Straddle blocks shall be installed to provide thrust restraint at the discretion of the District Engineer. Size and bearing area of straddle blocks is dependent on site-specific soils and other factors. Minimum dimensions and reinforcement are shown in Standard Detail 304. The Project Engineer shall provide stamped design calculations for straddle blocks on all pipes larger than 8 inches in diameter.

#### G. Casing Pipe, Spacers, and Seals

1. Underground water mains crossing a railroad, an ODOT right-of-way, or a stream shall be installed in a casing pipe unless otherwise approved by the District Engineer.
2. The size and extents of the casing shall be determined by the District Engineer on a case-by-case basis.

#### H. Cathodic Protection

1. Cathodic protection may be required for water mains larger than 12-inches in diameter or water mains deemed critical at the sole discretion of the District Engineer. Refer to [Section 1.4](#) for a description of the process for identifying critical water mains and proper application of these Standards.

- I. Polyethylene Encasement and Zinc Coating Requirements
  1. All new ductile iron pipe and fittings shall be mortar lined, zinc coated and encased in polyethylene wrap conforming to the requirements of ANSI/AWWA C105/A21.5. Zinc coating for new ductile iron pipe and fittings shall adhere to ISO 8179-1, unless otherwise approved by District Engineer.
  2. Mains that are deemed to be critical or larger than 12-inches must have destination soil tested to certify that the use of zinc coating and polyethylene encasement is sufficient for a proposed ductile iron pipe installation. District approved methods for soil corrosivity testing are described in [Section 9](#) of these Standards.
  3. Submit sampling plans and results of corrosivity testing as described in [Section 9](#) of these standards. If plans are deemed insufficient, work with District Engineer to determine what additional effort may be necessary.

## 3.2 Materials

### A. General Material Requirements

1. All pipe, fittings, and valves used within the District shall have restrained joints as specified herein.
2. See [Table 1-1](#) for specific water main material and cathodic protection requirements.
3. All ductile iron pipe and fittings shall be manufactured in the United States of America unless otherwise approved by the District. All other products manufactured outside of the United States of America shall provide address of manufacturing plant and origin of material certification prior to acceptance for use by District.
4. All components shall be NSF 61 certified.

### B. Ductile Iron Pipe

1. Ductile iron pipe shall be Class 52, unless specified otherwise by the District Engineer. Pipe shall conform to ANSI/AWWA C151/A21.51, NSF 61 certified, with asphaltic coating per ANSI/AWWA A21.4/C104.
2. Pipe shall be manufactured by:
  - a. U.S. Pipe
  - b. American Cast Iron Pipe Company
  - c. McWane Ductile
  - d. District approved equal
3. Ductile iron pipe 12 inches or smaller shall have push-on joints with restraining gaskets approved by the manufacturer for use only with their pipe unless otherwise stated. Gaskets shall be manufactured by:
  - a. U.S. Pipe, Field Lok 350® (for Tyton joint pipe)
  - b. McWane, Sure Stop 350® (for Tyton joint pipe)
  - c. American Cast Iron Pipe Co, FastGrip® (for Fastite joint pipe)
  - d. District approved equal
4. 16 inch or larger water mains must have integrated restrained joints and require District approval.

5. Ductile iron pipe and fittings shall be cement-mortar lined in accordance with ANSI/AWWA C104/A21.4.
  6. Exterior of ductile iron pipe shall be coated with a layer of arc-sprayed zinc conforming with ISO 8179-1. The mass of the zinc applied shall be 200 g/m<sup>2</sup> of pipe surface area. A finishing layer topcoat of standard asphaltic/bituminous coating shall be applied to the zinc. Pipe markings shall clearly indicate that a zinc coating layer has been provided.
  7. An NSF 61 compliant lubricant shall be supplied from the pipe manufacturer in sufficient quantities for installing the pipe.
- C. Mechanical Joint Fittings
1. Mechanical joint fittings shall be ductile iron compact per AWWA C153.
  2. Ductile iron fittings shall conform to ANSI/AWWA C110/A21.10 and/or ANSI/AWWA C153/A 21.53, NSF 61, asphaltic coating per ANSI/AWWA A21.4/C104 and zinc coating per ISO 8179-1
  3. Fittings shall be of a pressure rating equal to or greater than 150 psi unless otherwise required due to site specific conditions.
  4. Fittings shall have the following information cast upon them:
    - a. Manufacturer's identification
    - b. Country of manufacture
    - c. Pressure rating
    - d. Number of degrees or fractions of a circle (bends)
    - e. The District may require additional metallurgical documentation or other certifications.
  5. Fitting joints shall have mechanical joint (MJ) ends, except where specifically shown or detailed otherwise. Mechanical joint components shall be in accordance with AWWA C111.
  6. Bolts shall be T-head bolts, constructed from corrosion-resistant, high-strength low-alloy steel that conforms to ANSI/AWWA C111/A21.11 coated with a ceramic-filled fluorocarbon resin that can hold up in highly corrosive soil conditions or constructed from Type 316 stainless steel. Nuts and washers shall conform to the same coating requirements and shall match bolt material.
  7. All mechanical joints shall be restrained with:
    - a. Mechanical joint restraint shall consist of multiple gripping wedges incorporated into a follower gland meeting the applicable requirements of AWWA C110. Restraints shall be polyethylene wrapped to prevent backfill materials from entering wedge gripping area. Restraint models include:
      - 1) EBAA 1100 MEGALUG
      - 2) StarPipe Stargrip Series 3000
      - 3) Romac Romagrip
      - 4) Ford FUR
      - 5) District approved equal

- a. The joint restraint ring and wedge components shall be constructed of grade 65-45-12 ductile iron conforming to ASTM A536. Wedges shall be heat-treated to a minimum Brinell Hardness Number of 370. The dimensions of the follower gland shall be compatible with joint bells conforming to ANSI/AWWA A21.11/C111 and ANSI/AWWA A21.52/C153.
- b. Joint restraint shall be listed by Underwriters Laboratories (UL) and shall be Factory Mutual approved.

#### D. Flanged Fittings

1. Flanged fittings shall conform to ANSI/AWWA C110/A21.10 and shall be faced and drilled Class 125 flanges that match ANSI B16.1 fittings.
2. Flanged fittings allowed under ANSI/AWWA C110/A21.10 are ductile or gray iron.
3. Flange bolts, nuts, and washers shall be constructed from corrosion-resistant, high-strength low-alloy steel that conforms to ANSI/AWWA C111/A21.11 coated with a ceramic-filled fluorocarbon resin that can hold up in highly corrosive soil conditions or constructed from Type 316 stainless steel. Bolt, nut, and washer material shall match.
4. Gasket material for flanged joints in ductile iron pipe shall consist of 1/8-inch thick, full-face one-piece, rubber gaskets conforming to Section 4 of ANSI/AWWA C207 and ANSI B16.21 and shall conform to NSF 61 standards. Gaskets shall have one or more annular rings molded into the gasket to improve gasket performance.
  - a. The gasket shall be cut with holes to pass bolts.
  - b. Gasket material shall be free of corrosive alkaline or acidic ingredients. No phenolic materials shall be used.
5. Lining and coating shall conform to Section [3.2.B.5](#) and [3.2.B.6](#).
6. Flange coupling adapters shall be installed with strict adherence to manufacturer's torque limitations during installation and shall be manufactured by:
  - a. Romac, Alpha FC Style Couplings
  - b. EBAA Iron, Megaflange
  - c. District approved equal
7. At cathodically protected joints, flange isolation gaskets/kits shall be manufactured by:
  - a. Calipco, Type E Full Face Gasket
    - 1) Gasket Material Option #8: Garlock #3505
    - 2) Sleeve Material Option #1: Polyethylene
    - 3) Insulating Washer Option #1: Phenolic
  - b. District approved equal

#### E. Thrust and Straddle Blocks

1. Thrust block and straddle block materials shall be 3,500 psi minimum compressive strength concrete and reinforcement (if required) shall be #4 minimum diameter steel rebar with a minimum tensile strength of 30,000 psi.

F. Sleeves and Mechanical Couplings

1. Full-body sleeves for buried service shall be ductile iron with mechanical joint components. Sleeves shall be manufactured for the size and type of pipe to be installed. Mechanical joint sleeve gaskets shall conform to ANSI/AWWA C111/A21.11. Couplings shall be:
  - a. Dresser
  - b. Smith Blair
  - c. Alpha Style couplings by Romac
  - d. District Approved Equal
2. Mechanical couplings shall be ductile iron with rubber rings and bolts and nuts in accordance with [Section 3](#). Couplings shall be manufactured for the size and type of pipe to be installed. Couplings shall be:
  - a. Dresser
  - b. Smith Blair
  - c. Romac
  - d. District Approved Equal

G. Tapping Sleeves

1. Tapping sleeves shall be stainless steel and have a one-piece, full circumference gasket with a minimum working pressure of 150 pounds per square inch (psi). Tapping sleeves shall be manufactured for the size and type of pipe to be installed. Tapping sleeves shall conform to AWWA C223.
2. For areas within the water system with increased working pressures, tapping sleeves with a minimum working pressure of 250 psi may be required at the discretion of the District Engineer.
3. Branch outlet from tapping sleeve shall be a minimum of Schedule 10 material thickness and shall have a test plug.

**Table 3.2 Acceptable Tapping Sleeves**

Tap Size	Sleeve Types
Taps Larger Than 2", Size-on-Size, or Size by Reduced Size	Ford FTSS w/ 304 Flange JCM 432 w/ 304 Flange JCM 452 w/ 304 Flange* Mueller H-304SS w/ 304L Flange Romac SST III w/ 304L Flange Or Approved Equal
1.5" and 2" Taps	See <a href="#">Section 6.2.D</a> for Tapping Saddle requirements.
1" or Smaller Taps	Tap directly on the DIP. See <a href="#">Section 6</a> .

\* JCM 452 permitted only for outlet sizes larger than 8-inches  
Refer to Section E and Standard Detail 302 for tapping sleeve installation information.

#### H. Repair Clamps, Bands, and Sleeves

1. Repair clamps for abandoning existing water main connections or for repairing existing water mains shall be stainless steel, with one-piece gaskets. Repair clamps shall have a minimum working pressure of 150 psi and shall be manufactured to match the size and type of the pipe to be repaired.
2. Clamps shall be:
  - a. Model 131 by JCM
  - b. Model FS2 by Ford
  - c. 500 series by Mueller
  - d. Model 257 by Smith-Blair
  - e. Model SS1 by Romac
  - f. District approved equal

#### I. Casing Pipe, Spacers, and Seals

1. Casing Pipe
  - a. Casing pipe shall be smooth steel conforming to ASTM A36 with minimum yield strength of 36,000 psi.
  - b. The minimum wall thickness shall be as required by the jurisdiction governing the highway, railroad, or stream bed under which the casing will be installed. In no case shall the casing wall thickness be less than 1/4-inch.
  - c. Engineer shall provide cathodic protection design for casing pipe as needed. Confirm with District Engineer as casing may serve different purposes.
2. Spacers
  - a. Casing spacers shall be 12" wide, two piece construction, and all stainless steel.
  - b. The spacer shall have a minimum of four runners through 12" pipe size, six runners through 36" sizes and seven runners through 48" sizes to secure carrier pipe within the casing and to resist movement of the pipeline.
  - c. Casing spacers shall be as manufactured by:
    - 1) Cascade Manufacturing
    - 2) Calpico Inc.
    - 3) District approved equal
3. Casing seals shall be Model "C" custom pull-on casing ends, as manufactured by Calpico, Inc., or District approved equal.

#### J. Polyethylene Encasement

1. Where specified in [Table 1-1](#), encasement shall consist of three layers of co-extruded linear low density polyethylene (LLDPE) fused into a single thickness of 8-mils. The inside surface of the wrap shall be infused with a blend of antimicrobial biocide to mitigate microbiologically influenced corrosion (MIC) and a volatile corrosion inhibitor to control galvanic corrosion. Encasement shall be V-Bio or District approved equal. Polyethylene encasement shall conform to the values shown in Table 3.3.

**Table 3.3 Polyethylene Encasement Minimum Acceptable Values**

Properties	Values
Tensile Strength – MD	4300 psi
Tensile Strength - TD	3800 psi
Dielectric Strength	800 V/MIL
Impact Resistance	800 grams
Tear Strength – MD	2550 grams force
Tear Strength - TD	3184 grams force
Minimum Thickness	8 mils

2. Polyvinyl chloride (PVC) tape shall be 2-inch wide, adhesive-backed, 10-mil black adhesive tape, Christy's Pipe Wrap Tape, or District approved equal.

#### K. Detectable Warning Tape

1. Warning tape shall be used for pipe with diameter of 12-inches or larger per Standard Detail 201.
2. Plastic warning tape shall be acid and alkali-resistant clear virgin polyethylene film, 4-inches wide with minimum thickness of 5-mil overall. Tape shall be reverse printed using a diagonally striped design for maximum visibility and meet APWA color-code standard for identification of buried utilities. Tape shall have a minimum strength of 1,750 psi lengthwise and 1,500 psi cross wise.
3. The tape shall be manufactured with integral wires, foil backing or other means to enable detection by a metal detector when the tape is buried up to 3 feet deep. The metallic core of the tape shall be encased in a protective jacket or provided with other means to protect from corrosion.

#### L. Tracer Wire

1. Tracer wire shall be used for pipe with diameter of 12-inches or larger, any pipe deeper than 5 feet, any nonconductive pipe, or for critical water mains as required by District Engineer, and in accordance with Standard Details 201, 309, 310, and 311.
2. Provide permanent, bright-colored blue, continuous locate tracer wire consisting of a tin coating and copper conductor with polyethylene insulation. Locate wire shall be 19 gauge (AWG). Core material shall be comprised of high-tenacity, woven polyester with water blocking yarns encapsulated in a 30 mil, blue high density polyethylene (HDPE) jacket providing corrosion resistance, flexibility, impact strength and 1,800 pounds (lbs) tensile strength. Tracer wire shall not conduct an electrical current when struck by lightning and shall be designed for direct burial applications. When splices and lateral connections are made, only manufacturer's recommended connectors shall be used.
3. Nine pound magnesium grounding anode shall be Dow Galvomag, or District approved equal. Each anode shall come with an attached black wire that is manufacturer provided.



4. Tracer wire, connectors, and locate clips shall be TRACE-SAFE™, manufactured by NEPTCO, Inc. and produced in the U.S., or District approved equal.
  5. Water blocking connectors shall be TRACE-SAFE™, TS-12-19-IL, or District approved equal.
  6. Locate clips shall be TRACE-SAFE™, TS-19-IL-LC-C locate clip with cap, or District approved equal.
  7. Locate stations for tracer wire shall be located inside standard traffic-rated valve boxes with a “TVWD Locate” cast into the cover as indicated in Standard Detail 309 and 402. Locate stations or risers shall meet the requirements of the tracer wire manufacturer for compatibility with their product.
  8. Wired nuts shall be waterproof type.
  9. Split bolts shall be brass.
- M. Threaded Brass Pipe
1. Brass Pipe used shall be schedule 40 seamless red brass and shall conform to ASTM B43. Pipe shall be male iron pipe thread (MIPT) on both ends.

## 3.3 Construction

### A. General Requirements

1. Install ductile iron pipe according to AWWA C600 “Installation of Ductile Iron Water Mains and Their Appurtenances” and the manufacturer’s recommendations except as modified by the approved plans, District Standard Drawings, and these Standards.
2. In areas where excavation will occur within 10 feet of a critical main, an Inspector shall be present at all times.
3. When pipe-laying is not in progress, the open ends of pipe shall be closed by a watertight pipe cap, plug or other means as specified. The cap or plug shall be fitted with a means for venting. When practical, the cap or plug shall remain in place until the trench is pumped completely dry. Care must be taken to prevent pipe flotation if the trench fills with water. Prior to removal of the cap or plug for extending the line or for any other reason, air and water pressure in the line shall be released.

### B. Handling Pipe and Fittings

1. All pipe and fittings shall be loaded for delivery in such a manner as to avoid damage to the pipe or fitting. During delivery and storage onsite prior to installation, each pipe end shall be capped with a manufacturer provided pipe end cap to protect the inside of the pipe from dirt, dust, and contamination.
2. Handle pipe and fittings to prevent damage or contamination to the pipe, fitting, lining, or coating.
3. Load and unload pipe and fittings using hoists and slings to avoid shock or damage, and under no circumstances allow them to be dropped, skidded, or rolled against other pipe and fittings, or the ground.
4. Damaged or contaminated pipe and fittings will be rejected. Immediately separate all damaged or contaminated pipe and fittings and remove them from the site.

5. Protect threaded pipe ends with couplings or other means until properly installed. Inspect the pipe and fittings for defects prior to installation.
6. Store pipe on cradles. Keep the pipe or pipe joints free of dirt, other foreign material, or contamination. When pipe laying is not in progress, close the open ends of each pipe with caps or by other approved means to ensure cleanliness.
7. Pipe gaskets shall not be exposed to the sun during storage.

#### C. Cutting the Pipe

1. Cut pipe for inserting valves, fittings, or closure pieces in a neat manner without damaging the pipe, coating, or lining and leave a smooth end at right angles to the axis of the pipe. Do not flame cut.
2. Cut ductile iron pipe with milling type cutter or saw.
3. Dress cut ends of push on joint pipe by beveling, as recommended by the manufacturer.

#### D. Laying the Pipe

1. The pipe bedding, pipe zone, and backfill materials shall comply with [Section 2.1](#). Check the grade with a straight edge before laying each section of pipe and correct if necessary. Pipelines intended to be straight shall not deviate from straight alignment at any joint in excess of one inch horizontally or vertically between the pipe ends.
2. At each joint or bell, dig trench of ample dimensions in the bottom and sides of the trench to allow the joint to be properly made and to permit easy visual inspection of the entire joint.
3. Provide ample means of removing all water entering the trench, according to Section E. Do not lay pipe in water or when, in the opinion of the District Engineer or Inspector, trench conditions are unsuitable.
4. Do not drop pipeline materials into the trench. Carefully lower all pipe and appurtenances into the trench by means of a crane or other suitable equipment to prevent damage to materials and protective coatings.
5. Unless otherwise directed, lay pipe with bell end facing in the direction of the laying. For lines on steep slopes, face bells upgrade only.
  - a. Where pipe is deflected, see [Section 3.1.D](#).
  - b. Do not allow any foreign material to enter the pipe during storage or placement in the trench.
  - c. Joint lubricant shall be supplied by the pipe manufacturer. Joint lubricant shall be non-toxic, water soluble, and certified to meet NSF 61.
6. Cleaning Pipe and Fittings
  - a. For ductile iron pipe joints, clean the outside of the spigot and the inside of the bell with a wire brush. Remove all lumps, blisters, and excess coating from the bell and spigot ends of each pipe.
  - b. Wipe all dirt, grease, and foreign matter from fittings and the ends of MJ pipe and push-on joint pipe.

7. Ductile Iron Pipe
  - a. Lay and join pipe in strict accordance with the manufacturer's recommendations.
  - b. After the first length of restrained joint pipe is installed in the trench, secure pipe in place with approved backfill material tamped under and along sides to prevent movement. Keep ends clear of backfill. After each subsequent section is joined, place backfill to the spring line to prevent movement.
  - c. Lubricant for the pipe gaskets shall be furnished by the pipe manufacturer, and no substitutes will be permitted under any circumstances.
8. Mechanical Joint Fittings
  - a. Install the fittings furnished in accordance with the manufacturer's recommendations.
  - b. Clean the ends of the fittings to remove all dirt, mud, and foreign matter by washing with water and scrubbing with a wire brush.
  - c. Slip the gland and gasket on the plain end of the pipe. If necessary, lubricate the end of the pipe to facilitate sliding the gasket in place. Then guide the fitting onto the spigot of the pipe previously laid.
  - d. When multiple mechanical joints are connected above-grade prior to placement in the trench, provide a plan to ensure all joints will be properly stabilized during lifting and placement to avoid deflection and loosening of joints. Following placement of assembled piping and fittings into the trench, all bolts must be checked for compliance with manufacturer recommended torque.
9. Flanged Fittings
  - a. Bolts for flange fittings shall be full-nut installation (i.e., three full threads showing past nut).
  - b. Coat threads on bolts and nuts with a food grade anti-seize material to prevent thread galling and torque to manufacturer's recommended torque where stainless steel bolts and nuts are approved for use by District Engineer.
  - c. Buried flanged fittings shall be fully wrapped with three layers of 8 mil polyethylene sheet secured with polyethylene tape.
- E. Tapping Sleeves
  1. Only companies previously authorized by the District are permitted to perform taps.
  2. Coordinate with Inspector at least 48 hours prior to tapping. Inspector shall be onsite to witness tapping.
  3. Tapping sleeves shall be installed per the manufacturer's instructions. Generally, the installation process for tapping ductile iron or cast iron pipe shall be as follows:
    - a. Clean all dirt, corrosion, and other foreign material from the pipe surface.
    - b. Verify pipe diameter and tapping sleeve size.
    - c. Tapping sleeve gasket shall be one-piece, unless otherwise approved.
    - d. Apply pipe joint lubricant to pipe and gasket.

- e. Place the saddle section of the sleeve on the pipe and mate the band section with the saddle section. Ensure that gasket is properly positioned and that no foreign material is trapped between the pipe and gasket.
- f. Install lug bolts, position the sleeve, and hand tighten the lug bolts to hold the unit in place. Ensure that flange face is level for proper installation of valve.
- g. Tighten the bolts according to the manufacturer's recommended sequence to the recommended torque and verify final torque several times throughout the installation process.
- h. Install flange gasket, attach tapping valve per manufacturer's instructions, and support the assembly with blocking and shims.
- i. Pressure test the valve and sleeve assembly and check for leaks.
- j. Verify proper bolt torque, assembly alignment, and cutter size.
- k. Attach the drilling machine to the tapping valve and support entire assembly with blocking and shims.
- l. Tap pipe, close valve, and verify bolt torque on tapping sleeve.
- m. Open tapping valve slightly to flush any foreign material and provide pipe coupon to Inspector.
- n. Wrap tapping sleeve and valve in three layers of 8-mil polyethylene. Extend polyethylene wrap a minimum of 6 inches beyond the valve and tapping sleeve.
- o. Ensure that all pipes and valves are fully supported with compacted crushed rock bedding per Section F prior to backfilling.

#### F. Thrust Blocks

- 1. Thrust blocks shall be poured monolithically between the pipe and undisturbed native soil.
- 2. Fittings shall be wrapped in three layers of 8-mil polyethylene sheet secured with polyethylene tape prior to concrete placement.
- 3. All joints and fittings shall be accessible for repair after thrust blocking is in place.

#### G. Straddle Blocks

- 1. Straddle blocks shall be poured monolithically against the pipe and undisturbed native soil.
- 2. For ductile iron pipe, straddle blocks shall be poured around a minimum of two EBAA 1100SDB, or District approved equal, mid-span retainer glands are wrapped in polyethylene encasement as indicated in Detail 304 and in accordance with [Section 3.2.C.7](#) and installed per manufacturer's recommendations. Contact the District Engineer for straddle blocks on cast iron pipe.
- 3. Ensure that no unrestrained joints exist between the straddle block and pipe sections or fittings that are to be restrained.
- 4. Ensure concrete straddle blocks have cured sufficiently before removing pipe sections or fittings or otherwise inducing a load on the straddle block.
- 5. See Standard Detail 304.

## H. Cathodic Protection Relocation

1. In the event of cathodic protection on existing pipe is impacted by new pipe installations, the relocation of test stations shall only be done by District maintenance crews.

## I. Applying Polyethylene Encasement to Buried Pipe and Fittings

1. Install polyethylene encasement per ANSI/AWWA C105/A21.5 Method A, Modified DIPRA Method for Wet Trench Conditions, as shown in Detail 301. Cut polyethylene tube 2-feet longer than the length of pipe to receive the encasement. Provide a 1-foot minimum overlap for each adjacent pipe joint. Prior to placing the pipe into the trench, raise the pipe section with a fabric type sling or padded cable, and remove all soil and other debris from the pipe exterior. Slip the polyethylene tube over the spigot end of the pipe. Bunch up the tube in accordion fashion between the spigot end and the supporting sling holding the pipe.
2. Place the pipe on blocks with slackened sling in place so the polyethylene encasement can be spread over the entire barrel of the pipe.
3. Pull the loose polyethylene tube on the pipe snugly around the pipe barrel. Fold excess material over at the top of the pipe and secure the fold with circumferentially or spiral wrapped polyethylene tape at 2-foot maximum intervals along the length of the pipe.
4. Lower the pipe section into the trench and seat the spigot end into the bell of the previously installed pipe. Ensure that the polyethylene encasement is not stabbed into the previously installed pipe. Provide a shallow hole in the pipe bedding at the bell to facilitate the joint overlap. Ensure soil or bedding material does not become trapped on the exterior of the pipe between the pipe and the polyethylene encasement. In addition, ensure that soil or bedding material is not allowed to enter the pipe interior.
5. Remove the sling from the pipe leaving 1-foot of bunched up polyethylene tube at each end of the pipe for joint overlap.
6. To make joint overlap, pull the polyethylene tube from the bell end of the previously laid pipe over the spigot end of the current pipe and fold the tube around the pipe and secure with three circumferential wraps of 2-inch wide plastic adhesive tape or a plastic tie strap. Then pull the bunched up polyethylene tube on the spigot end over the wrapped pipe joint to the bell end. Fold polyethylene tube and secure with tape as previously described.
7. Install the next section of pipe in the same manner
8. Wrap all copper air and vacuum valve lines, copper service lines, copper sampling station lines with PVC adhesive tape (as specified in [Section 3.2.J.2](#)), half lapped, for a minimum of three feet from the main. Wrap all corporation stops.

## J. Applying Polyethylene Encasement to Buried Valves and Fittings

1. Wrap valves and fittings by pulling the bunched up polyethylene tube (where installed) from the adjacent pipe over the bells or flanges of the valve or fittings. Secure the tube to the valve or fitting body with 2-inch wide adhesive tape wrapped around the body of the valve or fitting. Then wrap the valve or fitting with three layers of 8-mil flat sheet of polyethylene. Place the sheets under the valve or fitting and fold in half. For valves, extend the sheet to the valve stem and secure the sheet in place

with 2-inch adhesive tape. Secure the sheets with tape around the valve stem below the operating nut and around the barrel of the connecting pipe to prevent the entrance of soil. Make sure the wrap does not impede movement of operating nut. For fittings, wrap and overlap the adjoining pipe a minimum of 1-foot and secure in place with 2-inch wide adhesive tape. Pour concrete anchor and thrust blocks, if any, after the wrap is in place.

K. Repairing Polyethylene Encasement

1. All efforts shall be made to install the polyethylene encasement free of tears, breaks or other defects. Polyethylene encasement with excessive holes shall require replacement of the damaged section at the District's discretion. Repair minor rips and tears in the installed polyethylene with PVC tape as specified in [Section 3.2.J.2](#).

L. Tapping Method for Polyethylene Encased Pipes

1. Direct Tapping Method for Services (1" or smaller)

- a. Completely clean and remove debris from the polyethylene encasement. Wrap three layers of polyethylene adhesive tape completely around the polyethylene encasement on the pipe to cover area where tapping machine will be mounted.
- b. Mount the tapping machine as normal to the area covered by the tape. Make the tap and install corporation stop directly through polyethylene encasement and tape.
- c. Inspect work and make repairs as necessary as outlined in [Section 3.3.K](#).
- d. Refer to [Section 3.3.1.8](#) for instructions on priming and tape wrapping services and corporation stops.

2. Tapping Method Using a Tapping Sleeve or Saddle (1.5" or Larger)

- a. Remove section of polyethylene encasement from the area that will be tapped. Secure free ends of polyethylene encasement on either side of the removed section by wrapping three layers of polyethylene adhesive tape circumferentially around the pipe.
- b. Install tapping sleeve or saddle and valve as normal to the area of the pipe clear of polyethylene encasement. Make the tap as required.
- c. After the tap has been made, inspect work and make repairs as necessary. Follow the steps outlined in [Section 3.3.J](#), Applying Polyethylene Encasement to Buried Valves and Fittings to encase the tapping sleeve or saddle and tapping valve.

M. Detectable Warning Tape (12 inches and greater pipe diameter)

1. Warning tape shall be installed directly above the pipe centerline at an elevation equal to the top of the pipe zone material unless otherwise directed by the District Engineer.

N. Tracer Wire (12 inches and greater pipe diameter)

1. Install tracer wire in accordance with manufacturer recommendations and do not splice wire unless splice and housing for splice meet the manufacturer's requirements.
2. Extend tracer wire to surface with a riser and install within a valve box for access. Tracer wire shall not be installed within the same valve box as an operational valve.

Risers for access to tracer wire shall be installed at the frequency necessary to obtain readable conductive signals or a maximum of 1,000 feet.

3. A successful conductivity test for all installed tracer wire will be necessary prior to acceptance of the system

#### O. Hydrostatic Testing, Flushing, and Disinfection

##### 1. Hydrostatic Test

- a. All pipelines, including service lines, intended to carry potable water shall be tested and disinfected before placing in service.
- b. The Contractor shall perform pressure and leakage tests on all newly laid pipe in accordance with District Standards. The District Engineer or Inspector shall be notified a minimum of 48 hours prior to testing and shall monitor the tests.
- c. The extents of pipeline sections to be tested will be determined by the Inspector.
- d. The tests shall be conducted after the trench has been completely backfilled and compacted.
- e. Equipment and Materials:
  - 1) Two approved graduated containers.
  - 2) Pressure gauges measuring in two-pound increments to max test pressure.
  - 3) Pump capable of providing adequate pressure for test procedure and approved by the District Engineer.
  - 4) Suitable hose and suction as required.
- f. Test Procedure
  - 1) After the trench has been backfilled and compacted, and any thrust reaction blocking has cured at least 5 days, fill the pipe with water with an approved method that protects the existing distribution system from possible contamination. The new mains being tested shall remain isolated from the existing water system.
  - 2) At the section of the line with the lowest elevation, use a pump to apply a test pressure of 150 psi or 1.5 times the normal working pressure, whichever is greater. Verify required static pressure with Inspector.
  - 3) Isolate the pump and hold the pressure in the line for 60 minutes, unless otherwise directed by the Inspector.
  - 4) At the end of the test period, operate the pump until the test pressure is again obtained.
  - 5) Measure the amount of water required to restore the test pressure. To measure accurately, the pump suction shall be in a barrel or metered.
- g. Leakage
  - 1) Leakage is defined as the volume of water necessary to restore the specified test pressure at the end of the test period.
  - 2) No pipe installation will be accepted if the leakage is greater than the number of gallons per hour as determined by the following equation:

$$L = \frac{S \cdot D \cdot P^{0.5}}{148,000}$$

where:

$L$  = Allowable leakage (gal/hour)

$D$  = Nominal pipe diameter (inches)

$S$  = Length of pipe tested (feet)

$P$  = Average test pressure (psi)

- 3) Should any hydrostatic test result in leakage greater than allowed, locate and repair the defective joints, pipe, or appurtenances and retest the pipeline. Repeat until leakage is below the specified allowance.

## 2. Flushing

- a. Prior to disinfecting the newly installed waterline, flush all foreign matter from the pipeline. Coordinate flushing activities with Inspector at least 24 hours in advance of flushing.
- b. Provide hoses, temporary pipes, ditches, etc., as required to dispose of flushing water without damage to adjacent properties. De-chlorinate discharged water utilizing best management practices.
- c. Flushing velocities shall be at least 2.5 feet per second (fps). For large diameter pipe where it is impractical to flush the pipe at 2.5 fps, clean the pipe in place from the inside by brushing and sweeping, then flush the line at lower velocity and discharge at least twice the volume contained in the section of pipe being flushed.
- d. To confirm services lines have not been kinked or bent, flow tests will be performed on all installed service lines to ensure full flow. District inspectors will perform flow testing. Any service line found to exhibit less than full flow shall be replaced at the Developer's sole expense.
- e. After disinfection, flush the chlorinated water from the line until the water through the line has chemical and bacteriological properties equal to the permanent source of supply.

## 3. Disinfection of Pipelines

- a. Pipelines intended to carry potable water shall be disinfected before placing it in service. Disinfection procedures shall conform to AWWA C651 in accordance with OAR 333-061-0050 (10) (c) and as hereinafter modified or expanded.
- b. Disinfection shall be accomplished using the continuous feed method to introduce a chlorine solution with a free chlorine residual of 25 to 30 milligrams per liter (mg/L) in a manner that results in thorough wetting of all surfaces and the discharge of all trapped air. A free chlorine residual in excess of 50 mg/L will not be allowed without specific approval by the District Engineer.
- c. The disinfection mixture shall consist of either calcium hypochlorite or sodium hypochlorite, and shall be prepared by the following:
  - 1) When using calcium hypochlorite, first mix the dry powder with water to make a thick paste, and then thin to approximately a 1% solution (10,000 mg/L chlorine).



- 2) When using liquid sodium hypochlorite, dilute the liquid with water to obtain a 1% solution.
- 3) The required proportions of hypochlorite to water are listed in Table 3.4:

**Table 3.4 Hypochlorite Solution**

Product	Quantity	Water Volume
Calcium Hypochlorite, <sup>1</sup> Ca(ClO) <sub>2</sub> 65-70% Chlorine	1 lb	7.5 gallon
Sodium Hypochlorite, <sup>2</sup> NaClO, 5.25% Chlorine	1 gallon	4.5 gallon

<sup>1</sup> Comparable to commercial products known as HTH, Perchloron, and Pittchlor.

<sup>2</sup> Known as liquid laundry bleach, Clorox, and Purex.

a) Injection into Pipeline

- 1) Inject the chlorine solution within the first 10-feet at the beginning of the pipeline section to be treated through a corporation stop or suitable tap in the top of the pipeline.
- 2) The disinfection mixture shall be injected into the pipeline at a measured rate while fresh water is allowed to flow through the pipeline at a measured rate so that the chlorine-water solution is of the specified strength.
- 3) Chlorinating devices for feeding the hypochlorite solution must provide means for preventing the backflow of water.
- 4) Do not place concentrated quantities of commercial disinfectant in the line before it is filled with water.

b) Operate all valves, hydrants, and other appurtenances during disinfection to ensure that the disinfection mixture is dispersed into all parts of the line, including dead-ends, new services, and similar areas that otherwise may not receive the treated water. Use check valves if necessary.

c) Retention Period

- 1) The chlorine solution shall be retained in the pipeline at least 24-hours to destroy all non-spore forming bacteria. At the end of the retention period, the disinfection mixture shall have a concentration of at least 10 mg/L of chlorine. To minimize damage to cement mortar lining in ductile iron pipe and fittings, disinfection solution contact time shall not exceed 60 hours.
- 2) If the residual measurement after 24-hours is found to be 10 mg/L or more, the chlorine solution shall be drained, and the pipeline flushed with potable water.
- 3) If the residual is less than 10 mg/L, the pipeline shall be flushed, re-chlorinated and rechecked until a final residual of 10 mg/L or more is achieved after a 24-hour standing time.

- 4) If the residual is greater than 10 mg/L, follow the bacteriological test procedure in Section e).
- d) Disposal of Disinfection Water
- 1) Dispose of disinfection water in an approved manner.
  - 2) Do not allow disinfection water to flow into a waterway without adequate dechlorination in accordance with ANSI/AWWA C655 "Field Dechlorination" to eliminate the chlorine residual.
- e) Bacteriological Test
- 1) Provide above grade access to sampling locations at the end of a 24-hour retention period. If the chlorine residual is greater than 10 mg/L, flush the disinfection water from the pipeline until the water through the line is equal in chemical and bacteriological properties to the permanent source of water.
  - 2) After flushing disinfection water is complete, coordinate with District staff to have them collect the first bacteriological (total coliform / E. coli) sample. Collection of the samples shall be done in time for the Inspector to deliver the sample to District headquarters by 2 pm, otherwise the sample collection may be delayed another day. After 24-hours and written confirmation from an approved laboratory that the first sample passed (i.e., free of total coliform / E. coli), then coordinate with District staff to collect a second bacteriological sample. If trench water and/or excessive quantities of dirt or debris have entered the pipeline during construction, bacteriological samples may be required at intervals of 200-feet in the vicinity of the occurrence.
  - 3) After the results of the second sample are available, and both tests indicate the water is free of coliform organisms, coordinate placing the pipeline in service with District personnel.
  - 4) If either sample does not pass (i.e., coliform is detected), the pipeline shall be cleaned, flushed, and disinfected again following the procedures outlined above. The process will continue until both bacteriological samples pass. The Contractor or Developer shall be responsible for reimbursing the District, according to the current District cost schedule, for any additional sampling and analysis of subsequent sampling, including staff time and analytical tests, following the initial pair of bacteriological tests. The District's current schedule for sampling and analysis costs is available upon request.

P. Inspection/Repair

1. Exterior Coating Repair: Pipe, fittings, and couplings shall be carefully inspected for damage to the outer protective coatings upon delivery. Damaged coating will result in automatic rejection of the product by the District. Field repairs of coatings are prohibited unless approved by the District Engineer.

# 4 Valves and Valve Boxes

## 4.1 General Requirements

### A. Isolation Valve Size, Spacing, and Location

1. Valve size shall match water main size.
2. Valves 8-inch or smaller, as well as all tapping valves, shall be gate valves. Valves larger than 8-inch shall be butterfly valves. All valves shall open with a counterclockwise rotation of a 2-inch square nut.
3. In general, spacing between isolation valves shall not exceed 800 feet.
4. Valves shall be installed on each branch of a tee or cross fitting unless otherwise directed by the District Engineer.
5. Refer to Standard Detail 401.

### B. Pressure Reducing Valves

1. The location, size(s), configuration, and settings of pressure reducing valves (PRVs, regulators) will be determined by the District Engineer to work in conjunction with the District's existing network of pressure zones. PRV submittals shall be sent to the District for review and approval.
2. PRVs shall be installed in a vault which shall conform to [Section 7](#) of these Standards. Contractor shall coordinate with the District to set PRVs.
3. PRVs shall be equipped with an adequately sized pressure relief valve located less than 500 feet downstream (low pressure side) of the valve. Pressure relief valves shall be located in an area where discharge is easily visible from the street, but where discharge will not cause flooding or property damage. Pressure relief valves shall be installed in a vault which shall conform to [Section 7](#) of these Standards.
4. An approved "H" strainer shall be installed within a distance of ten pipe diameters upstream (high pressure side) of the pressure reducing valves.
5. "Y" strainers will not be accepted, except for use on pilot control piping for the PRVs.

### C. Air and Vacuum Release Valves

1. An air release valve is required when the pipe has a high point that is at least one pipe diameter higher than the remainder of the pipe segment.
2. On 12 inch or larger diameter pipelines, air and vacuum release valves may be required at additional locations.
3. The air and vacuum release valves shall permit the release of large volumes of air when the line is being filled with water, the release of smaller amounts of accumulated air under normal operating conditions, and the re-entrance of air into the line to break any vacuum caused by the water leaving the line rapidly.
4. Generally, 8-inch or smaller mains shall have 2-inch air and vacuum release valves with 1-inch service per Standard Detail 404. Mains 12 inches in diameter shall have 2-inch air and vacuum release valves per Standard Detail 405. Mains larger than 12-inches in diameter shall have larger air and vacuum release valves as determined by the District Engineer.

5. The valves shall be designed to operate under working pressures of 150 psi or greater, (if needed), and shall have been tested by the manufacturer at a pressure not less than 300 psi.

## 4.2 Materials

### A. NSF 61 Certification

1. All valves shall be certified to NSF 61 to be suitable for contact with potable water. All wetted materials shall be suitable for potable water service with line content containing chlorine or chloramines.

### B. Gate Valves

1. Gate valves shall be ductile iron body, resilient seat/wedge, non-rising stem valves with O-ring seals, and shall conform to ANSI/AWWA C515 or C509.
2. Buried gate valves shall have mechanical joints, except tapping valves and hydrant tees which shall be mechanical joint by flange joint, or as directed by the District Engineer.
3. All exposed fasteners shall be Type 304 or 316 stainless steel.
4. Valves shall open when the stem is rotated counterclockwise. Unless otherwise shown, valves shall have 2-inch square operating nut.
5. Joint materials shall conform to ANSI/AWWA C111/A21.11.
6. Valves shall have an interior and exterior fusion bonded epoxy coating conforming to ANSI/AWWA C550 and C116/A21.16. Average dry film thickness shall be a minimum of 6 mils.
7. Valves shall operate with greater than 18 turns.

### C. Butterfly Valves

1. Butterfly valves shall be the rubber seated type, suitable for direct burial service. Valve shall be equipped with ductile iron body and 304 stainless steel shaft with 304 stainless steel journals. The butterfly valves shall conform to ANSI/AWWA C504 for Class 150B.
2. Buried butterfly valves shall have mechanical joints, or as directed by the District Engineer.
3. All exposed fasteners shall be 304 or 316 stainless steel.
4. Valves shall withstand 150 psi or greater (if needed) working pressure and 150 psi pressure differential across the valve.
5. Valve disc shall be ductile iron alloy conforming to ASTM A536 Type 1, chrome edged ductile iron with Buna N rubber seat bonded to the valve body, or ductile iron with rubber disc seat and 304 stainless steel mating surface attached to the valve body conforming to ANSI/AWWA C504, Section 4.3.5.3. Shaft and disc seals shall be designed for a drip tight seal.
6. Joint materials shall conform to [Section 2.2](#) and ANSI/AWWA C111/21.11.
7. Valves shall have an interior and exterior fusion bonded epoxy coating conforming to ANSI/AWWA C550 and C116/A21.16. Average dry film thickness shall be a minimum of 8 mils.

D. Butterfly Valve Operators

1. Butterfly valves shall be furnished with totally enclosed, integral valve operator designed to withstand a minimum of 300 foot-pound (ft-lb) input torque without damage to the valve or operator. Shear pins are not acceptable.
2. Operators shall be fully gasketed, grease packed, and designed to withstand submersion in water to a pressure of 10 psi.
3. Operators shall have a 2-inch square operating nut.
4. Butterfly valves shall open with a counterclockwise rotation of a 2-inch square nut. The number of turns required to move the disc from a fully opened position to a fully closed position shall meet the minimum number of turns listed in table 4.1. For valves larger than 18-inch, submit number of turns to District Engineer for approval.

**Table 4.1 Minimum Number of Turns**

Size	Number of turns to open/close
4"	15
6"	15
8"	15
12"	20
16"	30
18"	40

E. Operator Extensions

1. If the operating nut is deeper than 60 inches below finished grade, provide galvanized steel operating extensions to bring the operating nut to 18 inches below the ground or pavement surface.
2. The operator extension shall have a steel rock guard to allow centering of the stem in the valve box. Rock guard shall be located directly below the top operator nut and no less than six feet apart if the extension is eight feet or more in length. Add additional rock guards as necessary.
3. Refer to Standard Detail 403 for typical valve operator extension.

F. Acceptable Manufacturers

1. Only butterfly valves from the following manufacturers shall be provided for installation in the District's facilities:
  - a. Kennedy Valve
  - b. M&H Valve Company
  - c. Clow Valve Company
  - d. Mueller Co.
  - e. Pratt

- f. Val-Matic
2. Only gate valves from the following manufacturers shall be provided for installation in the District's facilities:
  - a. Kennedy Valve
  - b. American Flow Control
  - c. AVK Group
  - d. Clow Valve Company
  - e. East Jordan
  - f. M & H Valve Company
  - g. Mueller Co.
- G. Valve Boxes for Buried Gate and Butterfly Valves
  1. Valve boxes shall be one piece, cast iron type as manufactured by East Jordan or District approved equal. The valve box and cover shall be Model #3639A1 with "TVWD WATER" cast into the top as indicated in Standard Detail 402.
  2. A 6-inch diameter type ASTM D3034 standard dimension ratio (SDR) 35 PVC pipe shall be used as a spacer for the lower portion of the valve box. Length of spacer shall be as required depending on depth to operating nut.
  3. An 8-inch by 6-inch SDR 35 concentric reducer shall be glued to the bottom of the 6-inch PVC valve box spacer to prevent pullout as shown on Standard Detail 402.
- H. Pressure Reducing Valves
  1. Valves shall be Cla-Val Model 90-01 or 690-01 as manufactured by Cla-Val Co., or District approved equal.
  2. The PRV shall be a hydraulically operated, diaphragm-actuated, globe pattern valve, equipped with a resilient, synthetic rubber disc forming a tight seal against a single removable seat insert.
  3. Diaphragm
    - a. The diaphragm shall not be used as a seating surface. No packing glands, stuffing boxes, or valves with pistons are permitted.
    - b. Repairs shall be possible without removing the valve from the pipeline.
    - c. The diaphragm assembly shall be fully guided at both ends by bearings in the valve cover and seat. The diaphragm assembly shall be the only moving part and shall form a sealed chamber in the upper portion of the valve, separating operating pressure from line pressure.
  4. The pilot control shall be a direct-acting, adjustable, spring-loaded, normally-open diaphragm valve, designed to permit flow when controlled pressure is less than the spring setting. A fixed orifice shall be included in the control system. Pilot controls shall be bronze (ASTM B62).
  5. Pressure sustaining features may be required on PRVs as determined by the District Engineer.

6. The main valve and body shall be of ductile iron construction. The main valve trim shall be stainless steel.
  7. Pilot systems shall have an adjustment range of 30-300 psi or as directed by the District Engineer.
  8. The PRV shall be furnished with an internal and external 12 mil protective coating which shall conform to NSF 61.
  9. Valves shall accommodate at least 100 psi greater than the normal upstream working pressure in case of surge. District Engineer shall determine working pressures as described in [Section 4.1.B](#). Anti-Cavitation Trim may be required as determined by the District Engineer.
- I. Pressure Relief Valves
1. Valves shall be Cla-Val Model 50-01 or 650-01, as manufactured by ClaVal Co., or District approved equal.
  2. All valves shall come equipped with a normally closed pilot (CRL).
  3. Valves shall meet all other applicable requirements of Section H.
- J. 'H' Strainers
1. Strainers shall be Model X43H manufactured by Cla-Val Co., or District approved equal.
  2. Strainers shall be Class 125 or 250 as applicable for the system pressure. Strainers shall have flanged connections.
- K. Combination Air and Vacuum Release Valves
1. The valve inlets shall have iron pipe threads. The combination air and vacuum release valves shall be ARI Model D-040-C-2 for 2-inch size, or District approved equal for all water mains of 12-inch diameter or smaller.
  2. Type of combination air and vacuum release valves for water mains with diameters larger than 12-inches shall be determined and approved by the District Engineer.
  3. The pipe used for the air release valve assemblies shall be brass or copper tubing at the inlet and shall conform to Standard Details 404 and 405.
  4. Connection to main shall be per the requirements of [Section 6](#) (service lines).
  5. Enclose valves larger than 2 inches in two polyethylene meter boxes stacked together. Meter boxes shall be Model No. P6000495T as manufactured by Armorcast with mousehole or District approved equal. Lid shall be Armorcast Model No. A6000484R or District approved equal.
- L. Curb Stop Ball Valve
1. Curb stops shall be brass ball valve type with compression fittings when connecting to copper tubing, and female iron pipe thread (FIPT) when connecting to brass piping.

## 4.3 Construction

### A. Gate and Butterfly Valve Installation

1. Before installation, the valves shall be thoroughly cleaned of all foreign material and shall be inspected for proper operation to verify that the valves seat properly.
2. Valves shall be installed so that the stems are vertical, unless otherwise directed. Do not lift valves by the operator nut during installation or placement.
3. Wrap valve body with polyethylene encasement, secured with polyethylene tape prior to backfilling, as described in [Section 3.3.J](#) of these Standards.
4. Valves shall be carefully inspected for damage to the outer protective coatings prior to installation. Damaged coatings will result in the automatic District rejection of the valve. Field repairs of damaged coatings will not be permitted unless specifically approved by the District Engineer.
5. Joints
  - a. Joints shall conform to ANSI/AWWA C600. Valves shall be installed in accordance with Standard Detail 402.
  - b. Faces of flanges where applicable shall be cleaned thoroughly before flanged joint is assembled. After cleaning, the gasket shall be inserted, and the nuts tightened uniformly around the flange. For MJ restrained valves, the joint shall be assembled similar to other MJ fittings.
  - c. After tightening nuts, three full threads shall be showing on the end of the bolt where it is exposed beyond the nut.
  - d. Joints shall be tested with the adjacent pipeline for leakage. If joints leak under test, valves shall be disconnected and reconnected, and the valve and/or pipeline retested.

### B. Gate and Butterfly Valve Boxes

1. Center the valve boxes and set plumb over the operating nuts of the valves. Valve boxes shall not rest on the valve body. Set the valve box covers flush with the surface of the finished pavement or surrounding grade.
2. Access to valves, valve boxes, and valve lids shall be provided at all times to allow District to operate valves.
3. Cut PVC valve box extensions to the proper length so that the valve box lid does not rest on the extension when set at finished grade.
4. Backfill shall be the same as specified for the adjacent pipe. Place backfill around the valve boxes and thoroughly compact to a density equal to that of the adjacent trench, avoiding damage to or displacement of the valve box. Misaligned valve boxes shall be excavated, centered, set plumb, and backfilled at the Contractor's expense.
5. Where the valve is located in an unpaved area, the Contractor shall pour a concrete pad around the valve box which shall be flush with existing grade. The concrete shall be 24 inches square by 4 inches thick and shall be placed on a base of four inches of compacted crushed rock. Crushed rock shall meet the requirements of Section B. Refer to Standard Detail 402 for concrete pad.
6. Valve boxes shall be installed in conformance with Standard Detail 402.



### C. Air and Vacuum Release Valve Boxes

1. Thoroughly compact the gravel beneath the box and set the box so that it conforms to the elevation of the ground.
2. Place at least 12 inches of drain rock beneath the air release valve box to prevent water from collecting in the box. Crushed drain rock shall meet the requirements of [Section 5.2.H.](#)
3. Allow at least six inches of clearance between the top of the air and vacuum release valve and the top of the box.
4. All piping from the water main to the valve shall have an ascending slope up to the air release valve inlet to permit escape of any entrapped air.
5. Pressure test and disinfect air valve assemblies in conjunction with the pipeline.

DRAFT

# 5 Fire Hydrants

## 5.1 General Requirements

### A. Fire Hydrant Locations

1. Fire hydrants generally shall be placed at the radius point of curb returns at street intersections.
2. Midblock installations may be approved by the District but are not preferred. If installed at a midblock location, hydrant shall be placed at a property line between adjacent lots when possible.
3. Fire hydrants shall be placed a minimum of 18" and a maximum 24" behind top face of curb in a planter strip or 18" behind curbtight sidewalks. Refer to Standard Details 501 and 502. Fire hydrants within roadways under the jurisdiction of Washington County shall be placed a minimum of 24" behind face of curb.
4. Fire hydrants shall be placed in tree wells when building wall abuts the back of sidewalk. Hydrants shall not be placed in paved areas unless approved by District Engineer.
5. No part of any single family residential building shall be greater than 400 feet from a hydrant, as measured along the most practical accessible route unless approved by District Engineer.
6. No part of any commercial, industrial, or multiple tenant residential building shall be greater than 250 feet from a hydrant, as measured along the most practical accessible route.
7. No concrete, fencing, vegetation, or other obstructions interfering with the hydrant operation shall be installed in the hydrant clear zone. The clear zone is a triangular area that extends three feet behind a hydrant, five feet on each side, and is 20 feet wide at the curb. Refer to Standard Detail 503.
8. Place hydrants so as to provide complete accessibility and minimize possibility of damage from vehicles or injury to pedestrians.

## 5.2 Materials

- A. Fire hydrants shall be dry barrel, of the break flange or safety top type. Hydrants shall conform to ANSI/AWWA C502 and shall be painted Safety Yellow, Pitt-Tech Plus SG 4216 HP, above the ground line.
- B. The normal depth of bury shall be four feet. If mainline depth of bury prohibits normal depth of bury of the hydrant, the use of vertical bends shall be permitted.
- C. Hydrants shall be connected to the main with 6-inch ductile iron pipe and shall follow requirements of [Section 3](#).
- D. Fire hydrants shall have nominal 5¼-inch main valve openings, have 6-inch bottom connections, and be equipped with two 2½-inch hose nozzles and one 4½-inch pumped nozzle. Nozzle threads shall be American National Standard, and inlet connections shall be mechanical joint.
- E. Operating nut shall be 1½-inch national standard pentagon nuts.

- F. The main valve shall be equipped with O ring seals and shall open when turned counterclockwise.
- G. Only the following hydrants shall be provided for installation:
  - 1. Mueller Centurion or Super Centurion
  - 2. Kennedy K-81
  - 3. American Waterous Pacer
    - a) Upper Standpipe length shall be 16"
  - 4. M & H Model 129
  - 5. Clow Medallion
    - a) Stainless steel upper shaft
  - 6. AVK Series 27
  - 7. East Jordan 5CD 250
- H. Drain rock for hydrant installation shall be 1-1/2" and meet the requirements of ODOT Section 00430.11.
- I. Geotextile fabric shall be placed around drain rock and shall be nonwoven polypropylene fabric such as Mirafi 140N as manufactured by TenCate or District approved equal.

## 5.3 Construction

### A. Hydrant Installation

- 1. Hydrant installation shall conform to Standard Details 501, 502, and 503 as well as Section 3.7 of ANSI/AWWA C600, except where otherwise specified.
- 2. Connect to existing mains with tapping sleeve and gate valve installed per [Section 3.2.G](#) and Standard Detail 302. Tapping valve shall be flange by MJ gate valve and shall match hydrant line size.
- 3. For hydrant installations in conjunction with new main construction, connect to main with standard MJ by MJ by flange tee fitting and flange by MJ gate valve.
- 4. Refer to [Section 2](#) of these Standards for trench excavation and backfill for hydrant base and connection piping.
- 5. Do not excavate below subbase grade. Backfill over excavated areas with crushed rock per the requirements of Section B to provide a firm foundation.
- 6. Provide a square, level, concrete pier block underneath the hydrant. Block shall be eight inches thick and 12 inches on each side.
- 7. Place hydrant carefully to avoid damage to the pier block. Lower hydrant and appurtenances into the excavation by means of a crane, slings, or other suitable tools or equipment to prevent damage to the materials and protective coatings and linings. Jointing procedures shall conform to Section 4.3 of ANSI/AWWA C600.
- 8. All joints shall be restrained using MJ restrained joint follower glands per [Section 3](#).
- 9. After hydrant is in place and connected to the pipeline, place temporary blocks to maintain the hydrant in a plumb position during subsequent work.

10. Pier block and hydrant bottom shall be installed prior to placing drain rock. Drain rock shall be separated from undisturbed native soil and backfill with geotextile fabric. The drain rock pocket shall be not less than four cubic feet, and the top of drain rock shall be six inches above the hydrant drain opening. Once drain rock is in place bring remaining geotextile fabric over the top of the drain rock. Use enough geotextile fabric to wrap entirely around the drain rock with a minimum of one-foot overlap. Do not connect drainage system to sewer.
11. Set all hydrants plumb and nozzles parallel with or at right angles to the curb. When placed behind the curb or sidewalk, set hydrant barrel so that no portion of the pumper hose nozzle cap is less than 18 inches from the top face of the curb or backside of the sidewalk (if curbtight).
12. With the pumper nozzle facing the curb, set hydrants so that the safety/break away flange is a minimum of three inches and a maximum of six inches above finished grade or sidewalk level.
13. Improperly positioned hydrants shall be disconnected and relocated at the Contractor's expense.
14. Contractor shall install an 8" thick and 24" in length concrete collar below break flange, see Detail 502.
15. The upper exposed portion of the hydrant shall be thoroughly cleaned and painted with a prime coat of a rust inhibitive primer followed by a 10 mil dry film thickness (DFT) shop coat of heavy duty alkyd enamel paint.
16. Hydrant connections up to but not including the hydrant shall have the same coating as the water main to which they are connected. Hydrants connected to polyethylene encased water main shall have the polyethylene wrap terminate at the buried hydrant connection. The hydrant barrel shall be wrapped in polyethylene encasement from bury line to 6 inches below concrete block according to detail 502. Drain holes below ground shall not be encased in polyethylene wrap.

# 6 Water Service Connections

## 6.1 General Requirements

### A. General Requirements

1. Only District crews are permitted to work on, or make modifications to, the active water system, including installing new services, abandoning existing services, unless otherwise approved.
2. All mainline taps, service lines, meter boxes, and meter vaults to be constructed as part of new water system improvements shall be installed by the Contractor. For tapping existing mainline, refer to [Section 3.3.E](#).

### B. Service Installation

1. Water service installation shall be after road subgrade is cut and road base rock is installed to confirm minimum service line cover to be achieved.
2. Service installations within the extents of, but not limited to, a driveway, drive approach apron, water quality facility, or tree well, are not acceptable and will be required to be relocated at the Developer's sole expense.
3. Taps for service connections 1" or smaller shall be tapped directly into the mainline using a corporation stop. Taps larger than 1" or 1" taps on 4" pipe shall use a tapping saddle.

### C. Water Meter Sizing and Placement

#### 1. Provision of Water Meters

- a. Water meters shall be provided and installed by the District upon final acceptance of the water system improvements and payment of all required charges and fees pursuant to the requirements of Section 1.10 and the District's current Rules and Regulations.

#### 2. Meter Sizes

- a. The size of water meters shall be based on the total demand as reflected by the number of fixture units in the plumbing system. The meter size shall be determined according to methods and procedures outlined in Section 610.4 and 610.8 or Section 610.5 of the Uniform Plumbing Code (UPC).
- b. Where practical, 5/8-inch x 3/4-inch, and 3/4-inch meters will be served by a 1-inch copper service line with dual, or U-branch, service connections. Where a 1-inch meter is required for the purpose of providing adequate flow for a planned fire suppression system, the second meter served from the U-branch will be limited to a 3/4-inch meter. It shall be the responsibility of the Project Engineer to perform their due diligence to confirm that adequate flow and pressure can be provided to both service connections at all times.
- c. Dual, or U-branch, service connections are not permitted with multifamily or commercial development.
- d. Contact the District Engineer for additional requirements for meters larger than two inches.

### 3. Location of Meters

- a. The District generally requires placement of meters within planter strips, if available, or at the edge of the public right-of-way near the intersection of a property line. The District has the authority to move or change placement of water meters within the right-of-way, public utility easement (PUE) or on private property if an easement is to be granted, as necessary, to avoid being placed in paved surfacing, unless otherwise approved.
  - b. Meters 2-inch or smaller shall be located in a meter box within the planter strip, if available, or the PUE adjacent to the right-of-way at the property line.
  - c. If meters larger than 2-inches are not located in a vault within the right-of-way or the PUE, they shall be located in a vault on the Developer's property in a dedicated easement adjacent to the street right-of-way. The easement dimensions shall extend five feet beyond each outside wall of the meter vault.
  - d. No other utilities shall be located within three feet of a meter or service line unless approved by the District Engineer.
  - e. Meters served from a dual, or U-branch, service connection shall be installed in separate meter boxes located adjacent to the lot line.
  - f. Individual meters serving homes on private streets shall be installed in clusters or banks adjacent to the entrance of the private street.
4. Existing meter installations at older homes shall be checked for connections to ground wires from the home's electrical system. If District finds a "hot meter" with grounding wires from the home connected to the water piping, the District will coordinate with the homeowner to disconnect the grounding wires from the water piping. The District may also install electrical isolation at the meter to isolate the service line and water main.
  5. Backflow prevention assemblies are required on meters as defined in [Section 8](#), or at the District Engineer's sole discretion.

#### D. Temporary Irrigation Services

1. In locations where temporary irrigation services are required, the service shall be paired with a residential meter on a dual-service U-branch at the property line as described in [Section 6.2.F](#). The U-branch will be required if it is feasible to install, to allow freezing and abandonment of the temporary service without the need to dig up the street or shut down the main waterline.

## 6.2 Materials

### A. NSF Certification

1. All water service materials shall be certified to NSF 61 to be suitable for contact with potable water. All wetted materials shall be suitable for potable water service with line content containing chlorine or chloramines.

### B. Applicable Service Sizes

1. This section is applicable to 2-inch or smaller water service connections. For installation of water service connections larger than 2-inches, refer to Section 3 of these Standards.

### C. Copper Tubing

1. Copper tubing shall be Type K, soft, seamless, and annealed, conforming to ASTM B88.
2. Rolled copper is only permitted for 1" copper tubing. Straight copper tubes must be used for all 1.5" and 2" service connections, unless otherwise approved by the District Engineer.
3. Copper tubing shall be manufactured in the U.S.A. or Canada.

### D. Corporation Stops

1. Corporation stops shall meet the requirements of ANSI/AWWA C800, have AWWA taper thread (CC) inlet and compression connection (CTS) outlet, unless otherwise noted, and have a minimum pressure rating of 250 psi. All corporation stops shall be ball valve type. (Groundkey type corporation stops will not be accepted.)
2. Corporation stops for 1-inch copper service lines and sample stations shall have AWWA taper thread (CC) inlet and compression connection (CTS) outlet and shall be Ford FB1000-4-Q-NL, Mueller B-25008N, or District approved equal.
3. Corporation stops on cathodically protected mainlines for 1-inch copper services lines and sample stations shall have AWWA taper thread (CC) inlet and compression connection (CTS) outlet and shall be Mueller N-35008N, or District approved equal.
4. Corporation stops for combination air release valves (CARV) shall have AWWA taper thread (CC) inlet and MIPT outlet and shall be Mueller B-2996N, or District approved equal. Refer to Standard Detail 404.
5. Corporation stops are not permitted for 1.5" or 2" service lines unless otherwise allowed by the District Engineer.

### E. Tapping Saddles

1. Tapping saddles shall be double strap, minimum 1.5-inch-wide straps. Saddle outlet shall be 2-inch FIPT.
2. In the case of tapping 4" main, a saddle must be used. Saddle outlet shall be 1-inch FIPT.
3. Tapping saddle bodies shall be ductile iron with a fusion-bonded coating (epoxy or nylon). Straps, bolts, nuts, and washers shall be Type 304 stainless steel. Nuts shall be coated to prevent galling. Gasket shall be Nitrile (Buna N) rubber.
4. Tapping saddles shall have a minimum working pressure rating of 250 psi and shall be adequate for use with the size, type, and class of pipe.
5. Tapping saddles shall be Romac 202NS, Smith Blair 317, or District approved equal.

### F. Iron Body Gate Valves

1. Iron body gate valve shall have 2" FIPT inlet and outlet and meet the requirements of Section 4.2.B. Both 1.5" and 2" service connections shall use a 2" iron body gate valve.

### G. U-Branches

1. U-branches shall only be used with dual services and where water main pressure is 50 psi or higher.

2. U-branches shall be AY McDonald 708UQM (1" x 1" x 14"), or District approved equal.

#### H. Meter Setters

1. Meter setters shall have vertical FIPT inlet and horizontal FIPT outlet.
2. Meter setters shall include two flanged, lockable angle ball valves. Bypass with ball valve is required.
3. A 12" riser height is required for 1.5" meter setters. A 15" riser height is required for 2" meter setters.
4. 1.5" meter setters shall be Ford VBB76-86-12B-11-66-NL, AY McDonald 739R612WWFF 665, Mueller B-2429N with 12" riser, or District approved equal.
5. 2" meter setters shall be Ford VBB77-87-15B-11-77-NL, Mueller B-2429N with 15" riser, or District approved equal.

#### I. Brass Fittings

1. Brass fittings shall meet the requirements of ANSI/AWWA C800, have quick compression connection (CTS) inlet and outlet and shall be adequate for use with the size, type, and class of copper tubing.
  - a. Brass fittings shall be manufactured by Mueller, Ford, or District approved equal. Refer to Standard Detail 601 for allowable brass fittings.

#### J. Pipe Wrap Tape

1. Refer to [Section 3.2.J.2.](#)

#### K. Meter Boxes and Covers

1. Meter box sizes shall be as shown in Table 6.1. Approved meter box manufacturers include:
  - a. Armorcast
  - b. Brooks
  - c. DFW (Heavy Duty Series)
  - d. Sigma-Raven



**Table 6.1 Required Meter Boxes and Covers**

Meter size (inches)	Standard	Traffic Rated	Pedestrian Hard Surface	Non-Standard Hard Surface
1" or Smaller	<p>Armorcast A6000485 (Box) A6000484RCI (Lid)</p> <p>Brooks #37 (Box) with Reader Lid</p>	<p>Armorcast A6001946PCX12 (Box) A6001969TRCI (Lid)</p>	<p>Armorcast A6001946PCX12 (Box) A6001969TRCI (Lid)</p> <p>Brooks #38 (Box) with Solid Lid</p> <p>Sigma-Raven N1324BLKWAT</p>	<p>Armorcast A6001946PCX12 (Box) A6001969TRCI (Lid)</p> <p>Brooks #38 (Box) with Reader Lid</p> <p>DFW Plastics DFW1324C4-12-4CA</p> <p>Sigma-Raven N1324BLKWAT-RTO</p>
1-½ and 2	<p>Armorcast A6001640PCX18 (Box) A6001643RCI (Lid)</p> <p>Brooks #66 (Box) with Reader Lid</p> <p>DFW Plastics DFW1324C-4CT&lt;-&gt;-LID</p> <p>Sigma-Raven N1730BLKWAT</p>	<p>Armorcast A6001640PCX18 (Box) A6001947TRCI (Lid)</p>	<p>Armorcast A6001640PCX18 (Box) A6001947T (Lid)</p> <p>Brooks #66 (Box) with Solid Lid</p> <p>DFW Plastics DFW1730C4-12-4M-NHK</p> <p>Sigma-Raven N1730BLKWAT</p>	<p>Armorcast A6001640PCX18 (Box) A6001947TRCI (Lid)</p> <p>Brooks #66 (Box) with Reader Lid</p>

L. Angle Meter Stops

1. Angle valves shall be as shown in Table 6.2

**Table 6.2 Required Angle Meter Stops**

Valve size (inches)	Angle Valve Type
1	<p>Mueller B-24258N</p> <p>Ford BA43-444W-Q-NL</p>
1 U-branch	Mueller B-24265N

## 6.3 Construction

A. Staking

1. To provide proper layout of service lines and meter boxes, a professional surveyor licensed in the State of Oregon shall stake, in the form of setting laths, the following locations:
  - a. The intersection of property line(s) and the right of way(s)
  - b. The intersection of property line(s) and the public utility easement(s)

2. If curbs are installed at the time of service installations, the area behind the curb shall be leveled within ten feet of the back of curb to allow room to facilitate the installation of meter boxes at the proper elevation. The lot lines shall be clearly marked with lot numbers on the face of curb.
  3. If curbs are not installed at the time of service installation, or if curbs are not planned as part of development, meter box locations and grade hubs shall be staked for each meter.
  4. It is the responsibility of the Developer to ensure correct placement of all service lines and meter boxes per the approved engineering plans. Incorrect placement of service lines or meter boxes, either horizontally or vertically, shall be corrected at the Developer's sole expense.
  5. Refer to Standard Details 601 through 605B for typical water service installations.
- B. Service Line Installation
1. Trench excavation and backfill shall conform to [Section 2](#). Cover over pipe shall be as indicated on Standard Detail 201.
  2. Main Tapping
    - a. Taps shall be made in the pipe by experienced workers, using tools in good repair, with proper adapters for the size of pipe being tapped.
    - b. For 1" service line connections, taps shall be between 0° to 45° above the horizontal.
    - c. For 1.5" and 2" service line connections, taps shall be centered on the spring line of the pipe being tapped.
    - d. Taps shall be made no closer than 18 inches from the outside edge of the sleeve, corporation stop, or saddle to the beginning of the bell flare or MJ fitting.
  3. Tapping Saddles
    - a. Thoroughly clean the pipe surface and apply a suitable gasket lubricant per the manufacturer's instructions.
    - b. Position the saddle body over the pipe, install the straps, install the nuts to finger tight, and check to ensure that the gasket is seated flat onto the pipe face.
    - c. Tighten the nuts evenly in 20 lb. increments to the manufacturer's recommended torque specifications.
  4. Copper Tubing Installation
    - a. Copper tubing shall be cut with square ends, reamed, cleaned, and made up tightly.
    - b. Install copper tubing in full length segment without joints where possible. Where joints are required, use approved compression fittings.
    - c. Copper tubing bending radius shall be a minimum of 12 inches. Care shall be taken to prevent the tube from kinking or buckling on short radius bends. Kinked or buckled sections of copper tube shall be cut and the tube spliced with the proper brass fittings at the Contractor's expense.

- d. Copper tubing shall be wrapped with PVC adhesive tape (as specified in [Section 3.2.J.2](#)), half lapped, for a minimum of three feet from the main. Wrap all corporation stops.

#### C. Meter Box Installation

1. Meters and meter boxes shall be installed as shown in Standard Details 601, 603, 604, 605A, and 605B or as directed by the District Engineer.
2. Finish grade of completed meter enclosure shall allow a minimum of one inch and a maximum of four inches clearance from the top of the meter to the meter box.
3. Meter boxes shall be set or constructed plumb, with the top set horizontally. Grade adjustments of the meter boxes shall be done using standard extension sections for the box specified.
4. Lightly compacted earth backfill shall be placed inside of the meter boxes to depth indicated. Backfill around meter boxes as specified for adjoining pipe. Provide adequate space to allow for sidewalk installation.

#### D. Meter Installation

1. Installation of meters will be withheld until the District has accepted the project. Installation may occur prior to acceptance if a deposit or bond is provided to the District as described in [Section 1.10.A.7](#) of these Standards.
2. Meter shall be centered horizontally in the meter box such that meter can be read from the smaller box opening.
3. Prior to connection of the meter, the angle meter stop valve shall be opened, and the service line flushed of all foreign materials.
4. Depending on the elevation difference between the meter and the proposed building to be served, the District may require a gate valve or backflow prevention device on the customer side of the meter at the meter box.
5. Disinfection and hydrostatic tests shall be performed on the service connections and pipes according to Section 3.3.

# 7 Precast Concrete Vaults

## 7.1 General Requirements

### A. Vault Design

1. Vaults shall be provided for the following items:
  - a. Meters and backflow devices larger than two inches in size.
  - b. Pressure reducing valves.
  - c. Other appurtenances as required by the District.
2. Vaults located within private property shall obtain an easement to a minimum distance of 5 feet beyond the vault in all directions, allowing District staff the ability to access and maintain equipment.

## 7.2 Materials

### A. Base Rock and Concrete

1. Base rock and concrete shall conform to Section B.

### B. Precast Concrete Vaults

1. Concrete shall have a minimum compressive strength of 4,000 psi and be in accordance with ASTM C858.
2. The precast concrete vault shall have clearance of at least 12 inches between the enclosed device and the vault walls, unless otherwise specified within the Standards or by the District Engineer.
3. The ladder shall have a minimum perpendicular clearance of 30 inches from the centerline of the steps or rungs to the nearest object on the climbing side (in front of ladder) and a clear width of 15 inches on each side of the ladder centerline to the nearest permanent object (beside the ladder), along the entire length of the ladder. Ladder shall comply with OSHA 1910.23 requirements.
4. Vaults shall be of size sufficient to house the valve or device, ladder, other required equipment, and maintain the required clearances for safety and access. The District Engineer reserves the right to make the final determination on minimum acceptable vault size.
5. The vault shall have precast concrete top, center, extension, and base sections.
6. Crushed clean drain rock conforming to [Section 2.2.B](#) of these Standards shall be placed and leveled at the bottom of the vault interior to a minimum thickness of 15 inches to allow drainage.
7. Vault and components shall be as manufactured by:
  - a. Oldcastle Precast of Wilsonville, OR
  - b. Hanson Pipe & Precast of Portland, OR
  - c. District approved equal

### C. Ladders

1. Vaults shall be equipped with a ladder meeting the requirements of OSHA, as applicable, and as shown in Standard Detail 701.
2. Vaults 6-feet and greater in depth shall be equipped with an Old Castle Precast (utility vault) aluminum ladder extension safety post or approved equal.
3. Ladder extension shall extend 42 inches above the top rung of ladder. Ladder extension shall be CPP Columbia Aluminum Ladder Extension or District approved equal.
4. Ladders and accessories shall be fabricated steel with deformed rungs and shall be hot-dipped galvanized after fabrication.
5. Ladder shall be properly secured with stainless steel hardware of sufficient size according to manufacturer recommendations.

### D. Drainage

1. Provide a minimum 3-inch diameter bore-sighted drain to daylight with rodent screen, refer to Standard Detail 702.
2. If drain to daylight is not feasible, provide a sump pump per [Section 7.2.E](#).

### E. Sump Pumps

1. The sump for the vault shall conform to dimensions shown on Standard Detail 703. Sump pump for meter vaults shall be GC Systems automatic hydraulic sump pump assembly, with a normally closed intake valve connected to a free-floating liquid level switch that opens the intake valve when water in the sump reaches a set level. The ejector pump is powered by water pressure in the District main. Hydraulic sump pumps shall not be used in backflow vaults.
2. Hydraulic Pump shall be wall mounted with the sump pump suction inlet located within an 18-inch diameter PVC pipe placed on the interior floor of the vault and surrounded with crushed rock to a depth of 15 inches as described in [Section 7.2.B](#). The PVC pipe shall be perforated, and wrapped with Mirafi FW402 Filter Fabric, or District approved equal, to prevent intrusion or rocks and to allow water accumulating in the vault to freely enter the sump.
3. A double-check valve shall be installed on the hydraulic sump pump intake from the District water supply for backflow prevention. Supply water will be provided through a 1" tap, corporation stop, and Type K copper tubing. Supply water tap shall be upstream of meter.
4. Discharge piping shall be 1 ¼-inch diameter schedule 40 PVC, routed to an acceptable discharge location as approved by the District Engineer.
5. Hydraulic sump pump is preferred for meter vaults, but a powered option may be used upon District approval. Powered sump pump shall be:
  - a. Grundfos Model KP250 1/3 horsepower stainless steel, with a normally open free-floating liquid level switch that closes when liquid level rises.
  - b. Pump shall be equipped with 1-1/4-inch discharge and miscellaneous piping for discharge including an inline check valve and isolation gate valve (size equal to the discharge line size) downstream of the check valve.

- c. Provide power source at a voltage compatible with the sump pump motor. Conduit for power shall be a minimum of 2-feet from any other pipe penetration.

#### F. Vault Door

1. The top section of the vault shall be furnished with an aluminum sidewalk door. The model shall be:
  - a. Bilco Type JD-3ALH20
  - b. East Jordan Iron Works CHS Series
  - c. District approved equal
2. The door shall be furnished with the following:
  - a. Channel frame with an anchor flange around the perimeter
  - b. 1½-inch drain coupling
  - c. Aluminum diamond plate cover designed to withstand H-20 loading unless approved otherwise by District Engineer.
  - d. Compression springs to assist operation
  - e. Automatic hold-open arm with release handle
  - f. Safety grate only required where directed by District Engineer
  - g. Stainless steel safety chains are required for all vaults doors. Single door vaults shall have posts opposite of hinged door to support safety chain. Safety chains shall be a minimum height of 34-inches at lowest point including sag, maximum of 39-inches, and shall have a mid-span chain. Chains shall be powder coated orange for visual awareness.
  - h. Locking hasp
  - i. Snap lock with removable handle
  - j. Stainless steel hardware and hinges with stainless steel pins
3. The vault door shall be coated with a non-slip surface having a static coefficient of friction of at least 0.6 for flat surfaces and 0.8 for inclines greater than 4%.
4. Aluminum in contact with concrete shall be coated with bituminous coating.
5. The drain from the sidewalk door shall be stubbed-out to the exterior of the vault.

#### G. Vault Joints

1. Preformed plastic gaskets for horizontal vault joints shall meet requirements of Federal Specification SS-S-00210.
2. Gaskets shall be
  - a. Kent Seal No. 2, by Hamilton Kent Manufacturing Company
  - b. Ram-Nek by K.T. Snyder Company, Inc.
  - c. District approved equal

#### H. Grout and Damp-Proof Coatings

1. Damp-proof the exterior below-grade walls and base with a water-based blend that reacts with the free lime and calcium hydroxides in the concrete to seal the vault. Crystal Seal or District approved equal.
2. An asphalt compound of brush or spray consistency conforming to Federal Specification ASTM D449 may be used with the District Engineer's approval.
3. Vaults damp-proofed using clear compounds shall be marked in black paint as having received such a coating. The markings shall indicate the type of material used.

#### I. Pipe Supports

1. Provide support under all waterline piping in vaults with a Standon Model S89 Adjustable Pipe Support or District approved equal.

## 7.3 Construction

#### A. Vault Installation

1. Excavation, base rock, and backfill shall conform to [Section 2](#) of these Standards. If material in bottom of excavation is unsuitable for supporting unit, excavate and backfill to required grade with foundation stabilization.
2. Place precast vaults in conformance with Standard Details.
3. Install preformed plastic gaskets for vault sections in accordance with manufacturer's instructions and the following:
  - a. Carefully inspect precast vault sections to be joined. Do not use sections with chips or cracks in the tongue.
  - b. Install gasket material in accordance with manufacturer's instructions. Use only primer furnished by gasket manufacturer.
  - c. Completed vaults shall be rigid and watertight.
  - d. Top of vault lid shall be six inches above adjacent finished landscape grade. If installed in sidewalk or pavement, vault lid shall be flush with surrounding surface.

#### B. Pipe Penetrations

1. Openings in vault walls shall be no larger than 2-inches greater than flange diameter of pipe being installed.
2. Openings in vault shall be made using a core drill and the penetration shall be sealed using Link-Seal, Kor-N-Seal, or District approved equal, to keep the vaults as watertight as possible.
3. Prior to backfilling around vaults, use non-shrink grout to seal all joints, and patch wall areas with rock pockets in excess of 3/16" deep and greater than 3/4" in diameter.

# 8 Cross Connection Control Requirements

## 8.1 General Requirements

- A. Preservation of the quality of the public water supply is vital. No person may purposefully create a cross connection that may cause any wastewater, foreign liquids or substances, or water from an alternate source to enter the public water system. When a cross connection is identified, the owner must immediately remove the cross connection or install approved backflow protection.
- B. This Section is meant to provide a brief, though not exhaustive, overview of backflow prevention requirements. These requirements shall comply at all times with OAR 333-061-0070, OAR 333-061-0071, the UPC, District Resolutions, and amendments thereto.
- C. Backflow assemblies shall be customer owned and maintained, and bear all costs of installation, testing, and maintenance. Assemblies shall be tested immediately upon installation, annually thereafter, after repair, relocation, and after a backflow incident. Tests shall be conducted by an Oregon Health Authority certified tester or plumber, as specified by OAR 333-061-0072.
- D. Backflow assemblies shall meet the approval requirements of OAR 333-061-0070(13) and OAR 333-061-0070(14). Approved assemblies which provide water for human consumption shall additionally be listed as Lead Free per the EPA Lead Free Rule requirements.
- E. Backflow assemblies shall be installed on the service line at the property line, on private property outside of public easements. Per District Rules and Regulations, assemblies shall be available for inspection at all reasonable times.
- F. When a backflow assembly is installed behind the meter, the UPC may require additional equipment to be installed to control thermal expansion.
- G. The District reserves the right to discontinue water service if an unprotected cross connection exists, or if the required backflow prevention measures are not installed, tested, and maintained in accordance with these Standards. Service may not be restored until such conditions or defects are corrected and verified by the District.

## 8.2 Conditions Where Backflow Prevention is Required

Service connections described in Section 8.3.B.

- A. Where there is an auxiliary water supply such as a well that is, or can be, connected to potable water piping.
- B. Where there is pressurized piping for conveying liquids other than potable water, and where that piping is in proximity to the potable water piping.
- C. Where there is intricate plumbing that makes it impractical to ascertain whether a cross connection exists.



- D. Where unique conditions exist, but are not limited to, extreme terrain or pipe elevation changes, or structures greater than three stories in height, even with no actual or potential health hazard.
- E. Where there is a risk of back siphoning or back pressure.
- F. Where there is a cross connection or a potential cross connection.
- G. Where there is an irrigation system.
- H. Where there is a mobile apparatus that receives water from the District.
- I. Where there is a standby fire line, private fire hydrant, or fire suppression system.
- J. Where the District deems necessary following a cross connection control survey.
- K. The following exceptions to the above do not require backflow assemblies:
  - 1. Oregon Plumbing Specialty Code approved residential multi-purpose fire suppression systems constructed of potable water piping and materials do not require a backflow prevention assembly as specified by OAR 333-061-0071.
  - 2. Premises with an auxiliary water supply that has been certified as decommissioned by the State of Oregon will not require a backflow assembly upon submittal of the decommission certificate to the District.

## 8.3 Backflow Prevention Types and Hazards

- A. Approved Backflow Prevention Types
  - 1. Backflow Prevention Assemblies:
    - a. Double Check Valve Assembly (DC)
    - b. Double Check Detector Assembly (DCDA, DCDA Type II)
    - c. Pressure Vacuum Breaker (PVB)
    - d. Spill-Resistant Vacuum Breaker (SVB)
    - e. Reduced Pressure Backflow Assembly (RP)
    - f. Reduced Pressure Detector Backflow Assembly (RPDA, RPDA Type II)
  - 2. Backflow Prevention Devices:
    - a. Atmospheric Vacuum Breaker (AVB)
  - 3. Backflow Prevention Method:
    - a. Approved Air Gap
  - 4. The lists in Section 8.2 and [8.3.A](#) give basic guidelines and are not comprehensive. Refer to OAR 333-061-0070 and OAR 333-061-0071.
- B. Backflow Hazards
  - A. The type of backflow assembly required shall be commensurate with the degree of hazard of the premises, as determined by the District.
  - B. Non-Health Hazards requiring a minimum of a DC or DCDA:
    - a. At a minimum, an approved DC shall be required on the service connection at locations including, but not limited to, the following:

- 1) Customer connection classes defined in the District's current Rules and Regulations as: Residential Multi-Family, Non-Residential, Irrigation, Temporary Irrigation, Local Government/Water Provider, unless considered to be a Health Hazard connection, according to [8.3.B.3](#) of these Standards, which require a higher degree of backflow protection.
- 2) All service connections must comply with DC requirements of this section if an auxiliary water supply is present on the property, regardless of the degree of separation between the customer plumbing system and auxiliary water supply, unless compliant with [8.2.K.2](#) of this section.
  - a) Interconnected auxiliary water supplies shall meet the requirements of [8.3.B.3](#) of this section.
- b. At a minimum, an approved DCDA shall be required on the service connection at locations including, but not limited to, the following:
  - 1) Fire lines or standalone fire suppression systems without chemical injection or auxiliary water connections.
  - 2) Water services to private fire hydrants.
- C. Health Hazards Requiring minimum of an RP, RPDA, or Air Gap:
  - a. An approved RP shall be installed at the service connection and above-grade at locations including, but not limited to, the following:
    - 1) Premises which are listed or defined on, but not limited to, Table 42 of OAR 333-061-0070.
    - 2) Classified as Production in the District's current Rules and Regulations.
    - 3) Individually determined by the District on the assessment of a cross connection control survey.
  - b. An approved RPDA shall be installed above-grade at the service connection at locations including, but not limited to, the following:
    - 1) Fire lines or standalone fire suppression systems designed to use chemical injection.
    - 2) Fire lines or standalone fire suppression systems connected to an auxiliary water supply.
  - c. Air Gaps
    - 1) Air gaps are most commonly approved for the District's bulk water usage program. All bulk water access must be approved by the District.
    - 2) Approved air gaps must provide a physical separation between the free-flowing discharge end of a potable water supply pipeline and an open or non-pressure receiving vessel, as defined in OAR 333-061-0020(5).

## 8.4 Installation Requirements

### A. Installation of DCs and RPs

#### 1. Installation Location

- a. DCs and RPs of all diameters shall be installed at the water service connection as close to the meter as possible on the customer side of the water meter. The

installation shall be in accordance with these Standards, UPC, OAR 333-061-0070, and OAR 333-061-0071.

## 2. Below-grade Vault Installation

- a. Below-grade vaults must conform to [Section 3.3](#) and [Section 7](#).
- b. Inlet and outlet pipe spools shall be ductile iron. The assembly must be flanged, and the connection between the downstream piping and the backflow assembly must be made with a flanged coupling adapter. Inlet spool shall be flange by plain end, refer to Detail 801.
- c. RP and RPDA 2-1/2 inch and larger:
  - 1) Below-grade RP installations are approved by the District on a case-by-case basis and only when deemed necessary.
  - 2) The installation shall comply with Detail 803 of these Standards.
- d. DC and DCDA 2-1/2 inch and larger:
  - 1) The installation shall comply with Detail 801 of these Standards.

## 3. Above-grade Installation

- a. The assembly must have a District Engineer's approval.
- b. The inlet and outlet pipe spools shall be ductile iron, flange by plain end. The assembly must be flanged.
- c. Underground 90° bends shall be restrained with mechanical joint restraint as described in [Section 3.2](#). Above ground 90° bends shall be flanged.
- d. For assemblies 2-1/2 inches and larger, the enclosure shall be installed on a concrete slab with a minimum thickness of six inches and a minimum compressive strength of 3,000 psi. The slab shall be poured on a 4-inch leveling course of ¾-inch crushed, compacted rock.
- e. The enclosure shall meet UPC requirements for freeze protection, which requires outdoor enclosures to comply with ASSE 1060.
- f. All structures and wiring shall comply with local building codes.
- g. RP 2-1/2 inch and larger:
  - 1) Shall comply with Detail 802 of these Standards.

## B. Installation of DCDA and RPDA

### 1. General Requirements

- a. DCDA and RPDA of size 2-1/2 inch and larger shall be installed in accordance with Standard Details 801 through 803.
- b. Assemblies of size 2-1/2 inch and larger shall be flanged.
- c. Unless otherwise specified, the backflow assembly, concrete slab, piping, and all associated parts shall conform to [Section 3.3](#) and all applicable Standard Details.

### 2. Detector Meters

- a. Detector meters shall be installed with all RPDA, RPDA-II, DCDA, and DCDA-II assemblies.

- b. The detector meter shall be a Badger Recordall® Cold Water Bronze Model 25 (5/8-inch by 3/4-inch) that complies with ANSI/AWWA Standard C710.
      - c. The meter shall measure water flow in cubic feet.
    - 3. Below-grade Vault Installation
      - a. The backflow assembly and associated below ground installation components must conform to [Section 3.3](#), [Section 7](#), and [Section 8.4.A.2](#).
    - 4. Above Ground Installation
      - a. Refer to [Section 8.4.A.3](#).
  - C. Installation of PVBs, SVBs, and AVBs
    - 1. General Requirements
      - a. An approved PVB, SVB, or AVB shall be installed above-grade, in accordance with UPC, OAR 333-061-0070, and OAR 333-061-0071.
      - b. The customer must notify the District when a PVB, SVB, or AVB is re-plumbed, moved, and/or alterations are made to the downstream piping so the District may inspect for proper installation.
  - D. Approved Air Gaps
    - 1. General Requirements
      - a. All air gaps must be approved by a District cross connection control specialist and shall comply with OAR 333-061-0020(5).

# 9 Corrosion Control

## 9.1 General Requirements

### A. Resistivity Testing

1. Pipelines that are determined by the District to be non-critical, and with a diameter of 12 inches or less, do not require soil resistivity testing.
2. For pipelines that are greater than 12 inches in diameter and/or are determined by the District to be critical, a cathodic protection system design, including a preliminary design report, will be required.
  - a. Minimum cathodic protection for all mainline pipes shall be zinc-coated ductile iron pipe with polyethylene encasement.
  - b. Design of a cathodic protection system shall be performed by a Professional Engineer with a minimum of 5 years of experience performing cathodic protection work (design and testing), or either a NACE International certified Cathodic Protection Specialist or a NACE International certified Corrosion Specialist.
  - c. Personnel installing the cathodic protection system (anodes, joint bonds, test stations, etc.) shall be certified by the Corrosion Engineer / NACE International certified specialist to perform such tasks. Certification shall be in the form of a signed letter stating the name(s) of the personnel, and the cathodic protection tasks that said personnel are trained to perform.

### B. Sampling Plan

1. Prior to conducting any soil investigation, the corrosion protection designer shall prepare and provide the following information for review and approval by the District Engineer.
  - a. A map of the proposed project area, including the locations of any proposed water facilities, with the locations and types of soil investigations clearly indicated.
  - b. A description of each of the soil investigation methods to be used.
  - c. Deviations or modifications to the minimum investigation requirements described in [Section 9.1.D](#) of these Standards, including justifications for the deviation.
  - d. Qualifications and certifications for laboratories that will perform analysis and/or field personnel to conduct the investigations.
  - e. Descriptions of any encroachment permits, access agreements, traffic control, vegetation removal, restoration, or other measures required to complete testing and restore test locations to pre-existing conditions.

### C. Minimum Investigation Requirements

1. A soil investigation shall be performed prior to pipeline design to determine the resistivity and potential for corrosion. The following recommendations are the

minimum investigation requirements; however, the corrosion protection designer may recommend alternative methods within the sampling plan.

2. Both the Wenner Four-Electrode Method and the Two-Electrode Soil Box Method are accepted methods of performing soil resistivity measurements. Testing shall be performed in accordance with the latest version of ASTM G57 or ASTM G187.
3. Soil resistivity measurements shall be performed along the proposed pipe alignment at a minimum of two tests per block (or proposed block) in developed (or developing) areas, with spacing not to exceed 500 feet; or one test every 500 feet for non-developed areas.
  - a. The measurements shall be performed at proposed pipe depths in accordance with ASTM requirements.
  - b. If performed using the Wenner Four-Electrode Method, measurements shall be taken at 2.5 foot depth increments until a depth of 2.5 feet below the proposed pipe depth is reached (note that when using the Wenner Four-Electrode Method, "depth" refers to the spacing between the test electrodes). Resistivity of each 2.5 foot thick layer shall be calculated using the "Barns Layer" method.
4. Soil resistivity data records shall include a drawing showing test locations, as well as a data sheet containing the following information:
  - a. Name of tester
  - b. Date of test
  - c. Test ID number
  - d. Make and model of the testing equipment
  - e. General description and location of the test
  - f. Pin spacing measurements in centimeters
  - g. Soil resistance measurements in ohms
  - h. Calculated soil resistivity in ohm-centimeters

#### D. Soil Evaluation

1. After gathering and analyzing the soil resistivity data collected in the field, the soil resistivity sample exhibiting the least resistance along the pipeline route will be selected as the representative sample.
2. The preliminary design report shall include results from the resistivity testing, and shall identify other potential site-specific corrosion factors such as groundwater fluctuation, potential sources of stray electrical current, etc. which may impact the longevity of the pipe.
  - a. The corrosion protection designer shall recommend the appropriate corrosion control measures to achieve a minimum service life of fifty (50) years for the proposed facilities, including pipe material type and other cathodic protection design components. Recommendations and justification shall be included as part of a Preliminary Design Report that will be reviewed by the District Engineer. The corrosion protection designer shall provide design details and shall submit details to the District for review and approval.

CLASS "A" NATIVE BACKFILL  
OUTSIDE PAVED AREAS  
WITH DISTRICT APPROVAL

CLASS "B" GRANULAR BACKFILL  
WITHIN STREET RIGHT-OF-WAY

MOUND EXCESS BACKFILL MATERIAL  
TO ALLOW FOR SETTLEMENT

RESTORE LANDSCAPING TO  
PRE-EXISTING CONDITIONS

UNDISTURBED SOIL

TRACER WIRE AND  
DETECTABLE WARNING  
TAPE REQ'D FOR PIPE  
DIA. 12" OR GREATER

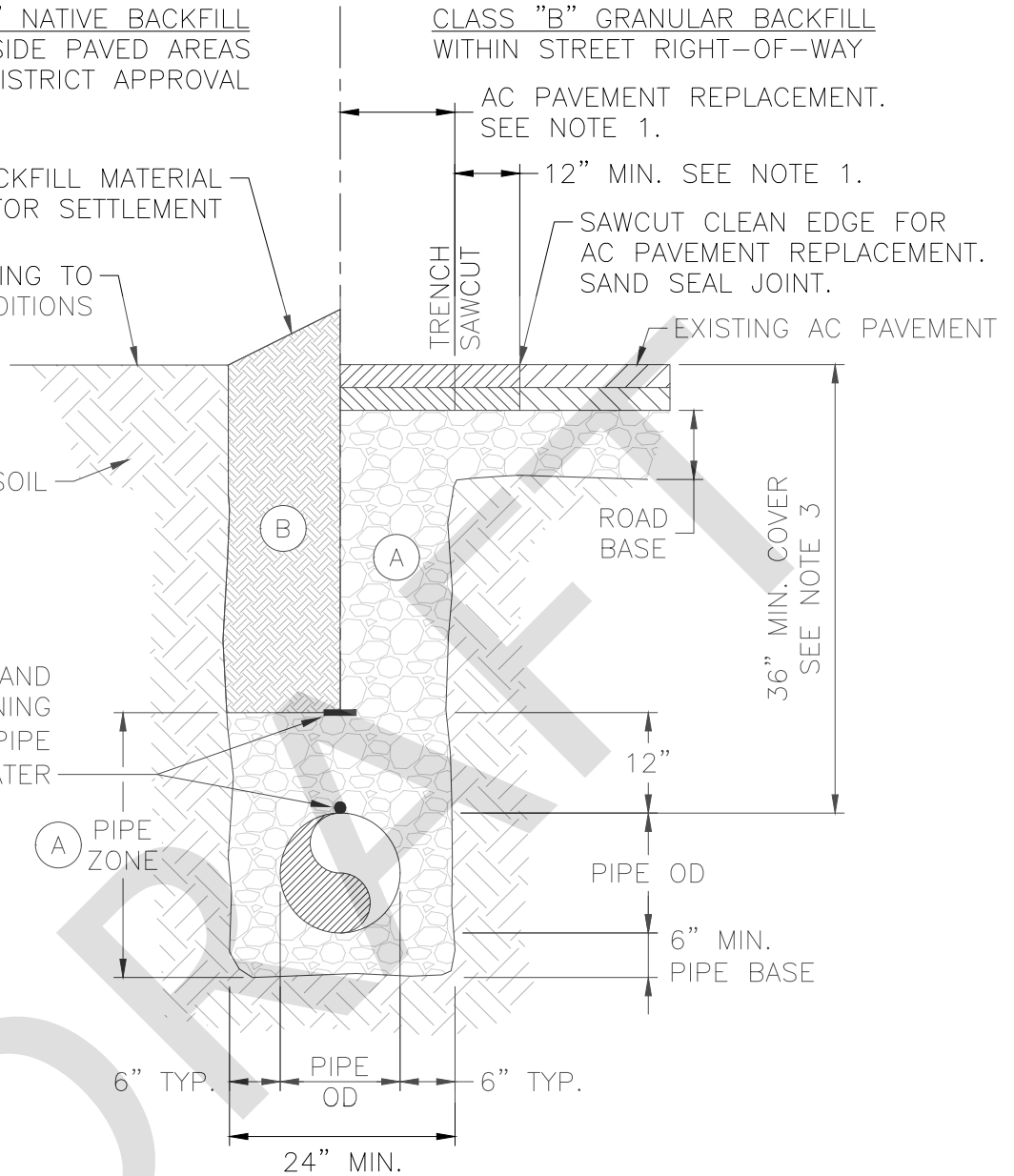

**KEYNOTES:**

- A. CLASS "B" 3/4"-0" CRUSHED ROCK GRANULAR BACKFILL COMPACTED TO 95% OF AASHTO T-99
- B. CLASS "A" NATIVE BACKFILL COMPACTED TO 90% OF AASHTO T-99 IN LIFTS NOT EXCEEDING 18" (LOOSE MEASURE)

**GENERAL NOTES:**

- 1. SAWCUT WIDTH AND AC PAVEMENT REPLACEMENT SHALL BE PER APPLICABLE JURISDICTIONAL REQUIREMENTS.
- 2. IF THESE SPECIFICATIONS CONFLICT WITH THE SPECIFICATIONS OF ANOTHER APPLICABLE JURISDICTION, THE MORE STRINGENT SPECIFICATION SHALL GOVERN.
- 3. 36" MINIMUM COVER IS REQUIRED. COVER DEEPER THAN 36" SHALL BE APPROVED BY DISTRICT ENGINEER.

N:\Standards\2024\Details\DWG\201\_Typical Trench Backfill.dwg, 6/13/2024 10:43:28 AM



**TUALATIN VALLEY  
WATER DISTRICT**

APPROVED BY  
PETER BOONE

DRAWING SCALE  
NONE

TYPICAL TRENCH BACKFILL

EFF. DATE 07/01/24

STANDARD DETAIL

201

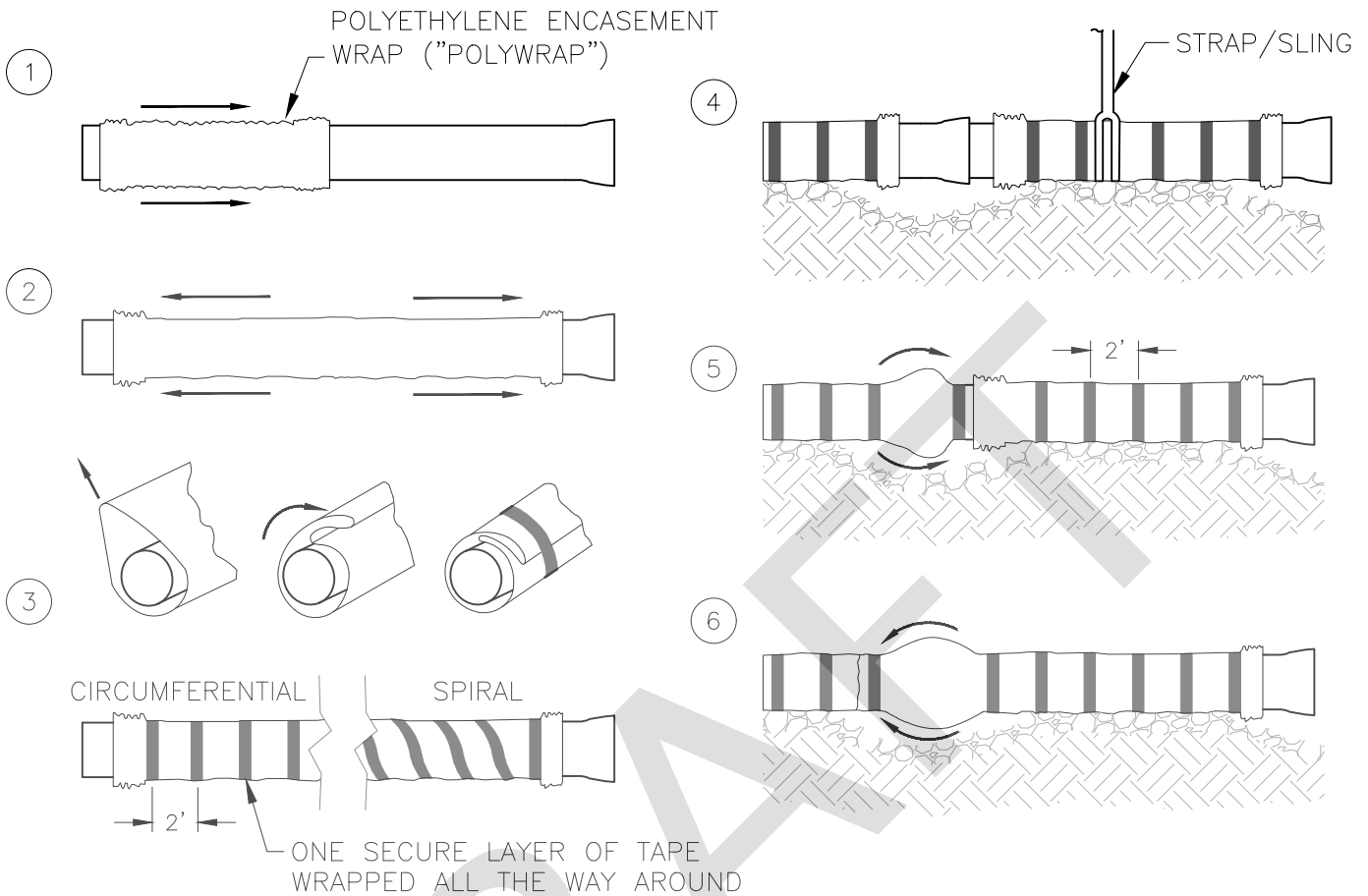

**KEYNOTES:**

1. CUT THE POLYETHYLENE ENCASEMENT WRAP ("POLYWRAP") TWO FEET LONGER THAN PIPE AND SLIP OVER PIPE BARREL.
2. EVENLY SPREAD POLYWRAP ALONG LENGTH OF PIPE BARREL, PROVIDING ONE FOOT OF SLACK AT EACH END.
3. TAKE UP SLACK IN THE TUBE ALONG THE PIPE BARREL, MAKING A SNUG BUT NOT TIGHT FIT. FOLD OVER ON TOP OF PIPE AND SECURE IN PLACE WITH ONE LAYER OF CIRCUMFERENTIALLY OR SPIRAL WRAPPED TAPE ABOUT TWO FEET ON CENTER. (PE SHOWN LOOSE FOR CLARITY) TAPE SHALL BE 10-MIL BLACK ADHESIVE PVC TAPE, CHRISTY'S PIPE WRAP TAPE, OR APPROVED EQUAL.
4. LOWER PIPE INTO TRENCH, ENSURING TO NOT DAMAGE POLYETHYLENE WRAP. MAKE UP JOINT.
5. PULL FORWARD POLYWRAP FROM PREVIOUSLY PLACED PIPE STICK OVER BELL. SECURE IN PLACE.
6. PULL POLYETHYLENE FROM NEW PIPE OVER THIS SAME BELL, PROVIDING A DOUBLE LAYER OF POLYWRAP. SECURE IN PLACE.

N:\Standards\2024\Details\DWG\301\_Polyethylene Encasement Installation Method.dwg, 6/13/2024 10:43:51 AM



**TUALATIN VALLEY  
WATER DISTRICT**

APPROVED BY  
PETER BOONE

DRAWING SCALE  
NONE

POLYETHYLENE ENCASEMENT  
INSTALLATION METHOD

EFF. DATE 07/01/24

STANDARD DETAIL

301



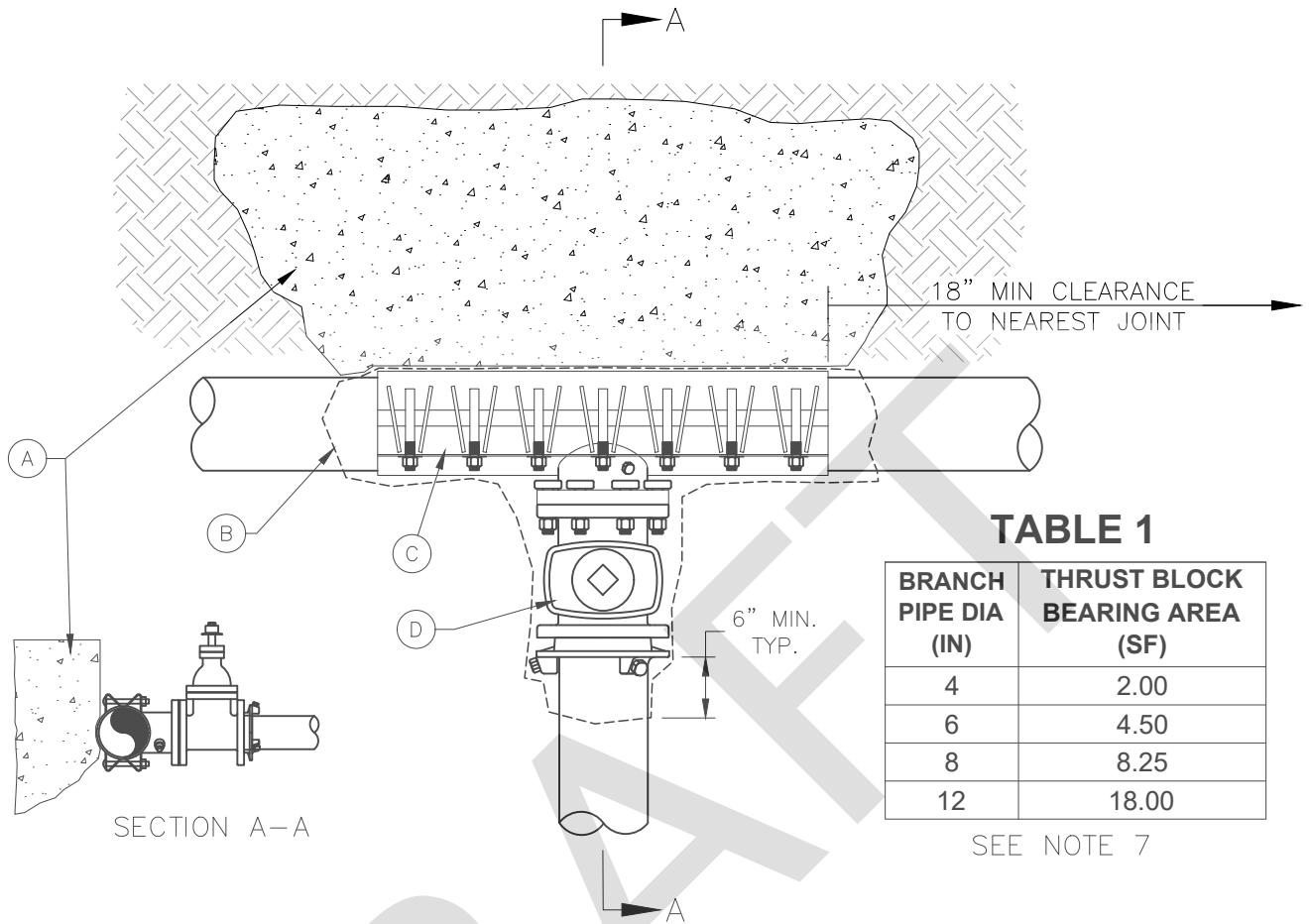

**TABLE 1**

BRANCH PIPE DIA (IN)	THRUST BLOCK BEARING AREA (SF)
4	2.00
6	4.50
8	8.25
12	18.00

SEE NOTE 7

**KEYNOTES:**

- A. CONCRETE THRUST BLOCK POURED AGAINST UNDISTURBED EARTH. THRUST BLOCK SIZE SHALL BE PER TABLE 1 AND SHALL NOT BE LESS THAN ONE FOOT IN ANY DIMENSION. CONCRETE SHALL BE MINIMUM 3500 PSI. BRANCH PIPE SHALL NOT BE PRESSURIZED FOR 5 DAYS.
- B. WRAP TAPPING SLEEVE AND VALVE WITH POLYETHYLENE ENCASUREMENT PRIOR TO POURING THRUST BLOCK AND BACKFILLING. EXTEND POLYETHYLENE 6" MINIMUM BEYOND SLEEVE AND VALVE AND SECURE TO PIPE WITH 10-MIL ADHESIVE PVC TAPE. SEE DETAIL 301.
- C. STAINLESS STEEL TAPPING SLEEVE WITH ONE PIECE, FULL CIRCUMFERENCE GASKET AND FLANGED CONNECTION.
- D. LINE-SIZE GATE VALVE (FLG X MJ) PER DETAIL 402.

**NOTES:**

- 1. BEFORE INSTALLING TAPPING SLEEVE, CONTRACTOR SHALL THOROUGHLY CLEAN PIPE TO REMOVE ALL DIRT, ROCKS, AND OTHER FOREIGN MATERIAL FROM PIPE WHERE SADDLE WILL BE INSTALLED.
- 2. SLEEVE BOLTS SHALL BE TORQUED TO MANUFACTURER'S SPECIFICATIONS. BOLTS SHALL CONFORM TO ANSI/AWWA C111/A21.11.
- 3. CONTRACTOR SHALL ENSURE THAT GASKET IS PROPERLY ALIGNED AND FREE OF FOREIGN MATERIAL PRIOR TO TIGHTENING SLEEVE.
- 4. TAP LOCATION AND INSTALLATION SHALL BE APPROVED BY DISTRICT INSPECTOR PRIOR TO TAPPING.
- 5. CONTRACTOR SHALL AIR TEST SLEEVE TO 40 PSI PRIOR TO TAPPING.
- 6. CONTRACTOR SHALL FLUSH AND PRESSURE TEST VALVE PRIOR TO BACKFILLING.
- 7. ENGINEER SHALL PROVIDE CALCULATION AND SIZING IF TEST PRESSURE EXCEEDS 150 PSI. SAFETY FACTOR SHALL BE 1.5.

N:\Standards\2024\Details\DWG\302\_Tapping Sleeve.dwg, 6/13/2024 10:44:22 AM



**TUALATIN VALLEY**  
WATER DISTRICT

APPROVED BY  
PETER BOONE

DRAWING SCALE  
NONE

TAPPING SLEEVE

EFF. DATE 07/01/24

STANDARD DETAIL

302

**KEYNOTES:**

- A. SAMPLING STATION. THE KUPFERLE FOUNDRY CO. ECLIPSE No. 88. MAINTAIN 24" CLEAR SPACE ON ALL SIDES.
- B. VALVE BOX ASSEMBLY PER DETAIL 402. VALVE BOX SHALL BE CENTERED AND PLUMB ON AXIS OF CURB STOP NUT. VALVE BOX SHALL NOT REST ON CURB STOP ASSEMBLY. DOGHOUSE PVC REDUCER OVER CURB STOP.
- C. BALL VALVE CURB STOP
- D. 8" X 6" PVC SDR35 D3034 REDUCER SXS, CONNECT TO PIPE USING A COMPATIBLE PVC CEMENT.
- E. WHEN OUTSIDE THE PAVED AREA PROVIDE 4" THICK CONCRETE PAD OVER 4" COMPACTED 3/4"-0" CRUSHED ROCK WHEN REQUIRED BY DISTRICT ENGINEER. PAD SHALL EXTEND OF A MINIMUM OF 6" AROUND VALVE BOX AND SAMPLE STATION. REINFORCE WITH #4 REBAR MAX 12" O.C. CENTERED VERTICALLY IN PAD. PROVIDE 3" CLEARANCE FROM EDGES AND PENETRATIONS. SEE DETAIL 402.
- F. 1" TYPE K SOFT COPPER TUBING
- G. CORP. STOP, DIRECT TAP DI PIPE
- H. MIPT X COMPRESSION FITTING TYP.
- I. 8" X 8" CONCRETE PIER BLOCK ON UNDISTURBED NATIVE SOIL.
- J. FIPT X MIPT 90 DEGREE BEND
- K. TAPE WRAP THE FIRST 3' OF COPPER TUBING.

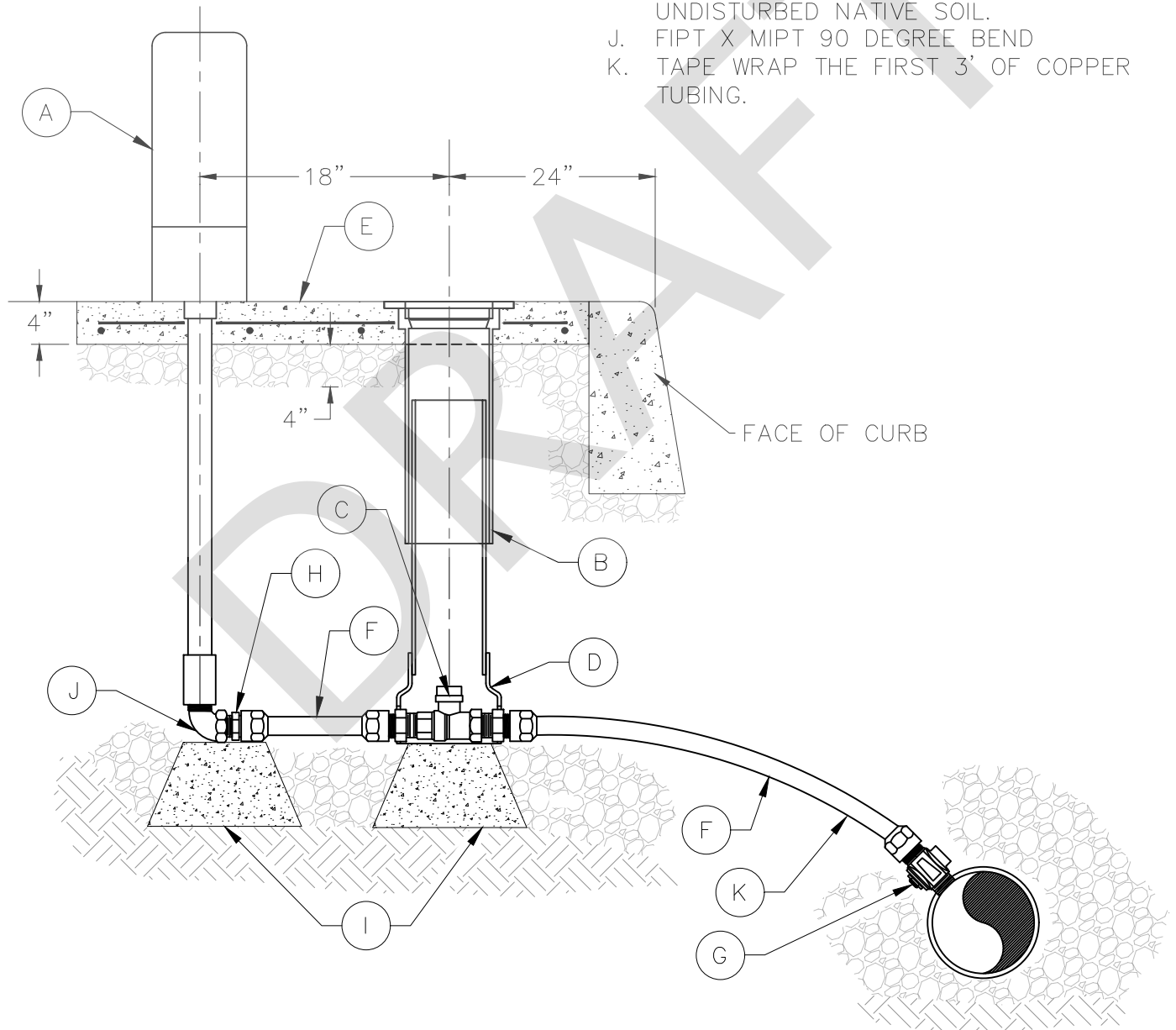

N:\Standards\2024\Details\DWG\303\_Sample Station.dwg, 6/13/2024 10:44:44 AM



**TUALATIN VALLEY**  
WATER DISTRICT

APPROVED BY  
PETER BOONE

---

DRAWING SCALE  
NONE

SAMPLE STATION

EFF. DATE 07/01/24

---

STANDARD DETAIL  
303

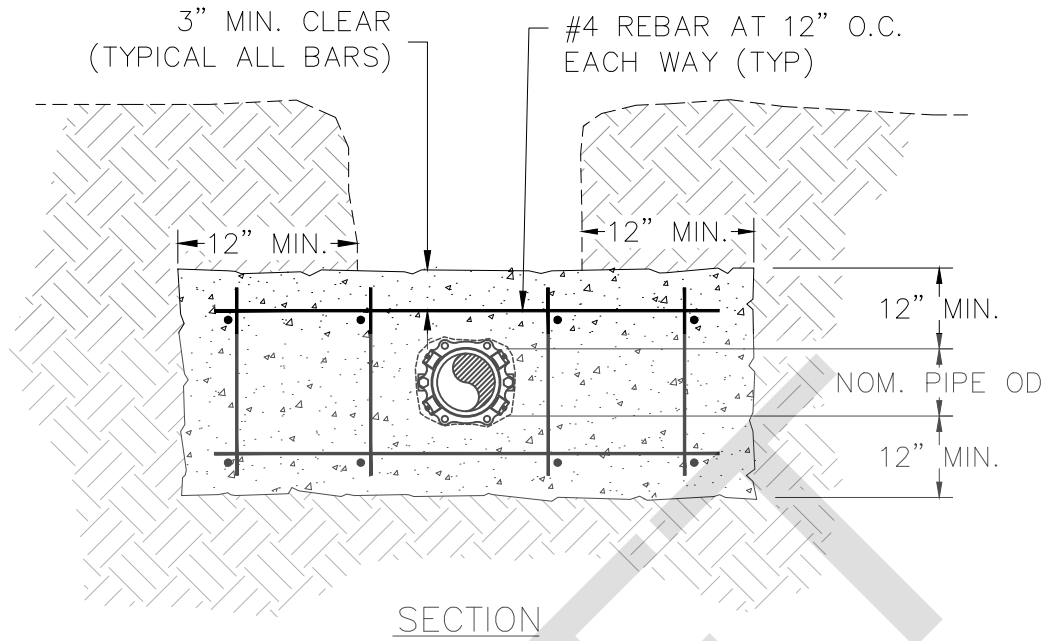

SECTION

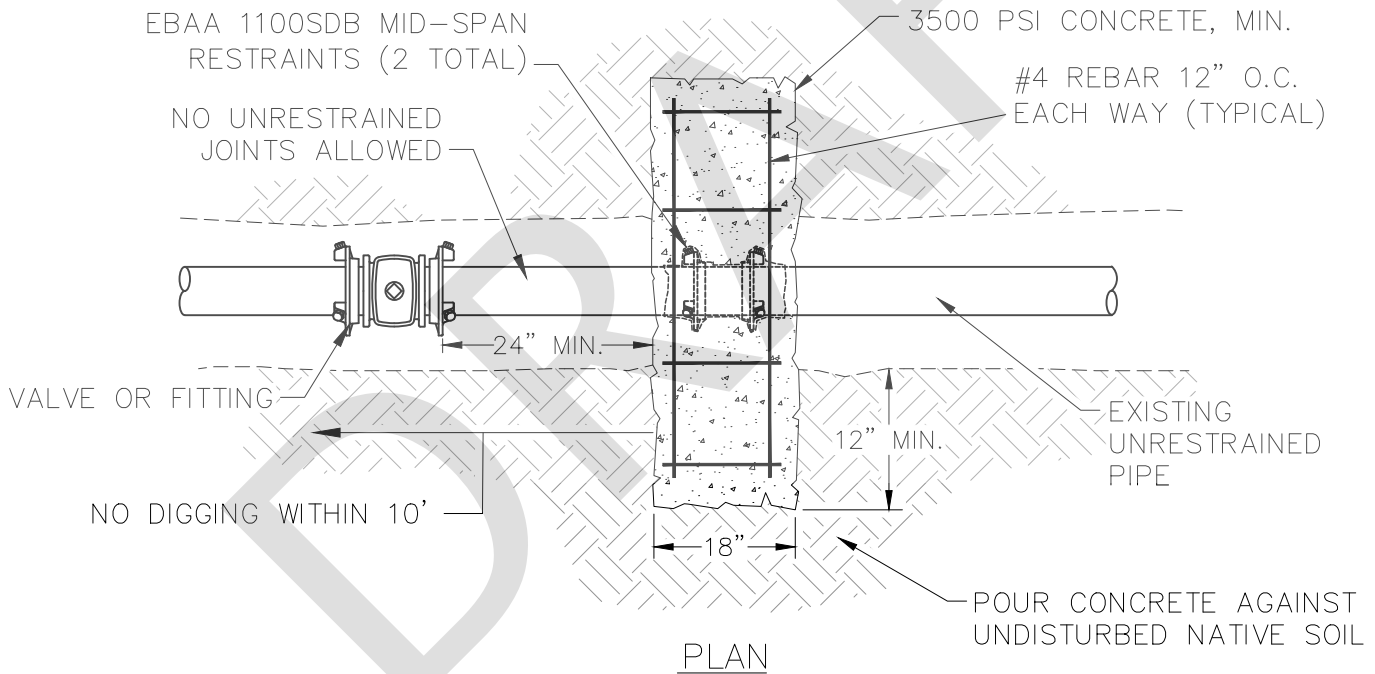

PLAN

**NOTES:**

1. STRADDLE BLOCKS FOR WATER MAIN 12" OR LARGER SHALL BE DESIGNED AND STAMPED BY THE ENGINEER OF RECORD. PROVIDE CALCULATIONS FOR REVIEW AND APPROVAL, AND INCLUDE A SAFETY FACTOR OF 1.5.
2. USE 2" OFFSET OR MANUFACTURER RECOMMENDATION FOR MID-SPAN RESTRAINT.
3. WRAP RESTRAINTS WITH 1 LAYER OF POLYETHYLENE ENCASUREMENT PRIOR TO POURING CONCRETE. EXTEND PE WRAP A MINIMUM OF 6" BEYOND RESTRAINTS. SECURE TO PIPE WITH 10 MIL PVC PIPE WRAP TAPE.
4. ENGINEER OF RECORD SHALL PROVIDE DESIGN AND SUPPORTING CALCULATION IF TEST PRESSURE EXCEEDS 150 PSI.

N:\Standards\2024\Details\DWG\304\_Straddle Block for Ductile Iron Pipe.dwg, 6/13/2024 10:45:23 AM



**TUALATIN VALLEY**  
WATER DISTRICT

APPROVED BY  
PETER BOONE

DRAWING SCALE  
NONE

STRADDLE BLOCK FOR  
DUCTILE IRON PIPE

EFF. DATE 07/01/24

STANDARD DETAIL

304

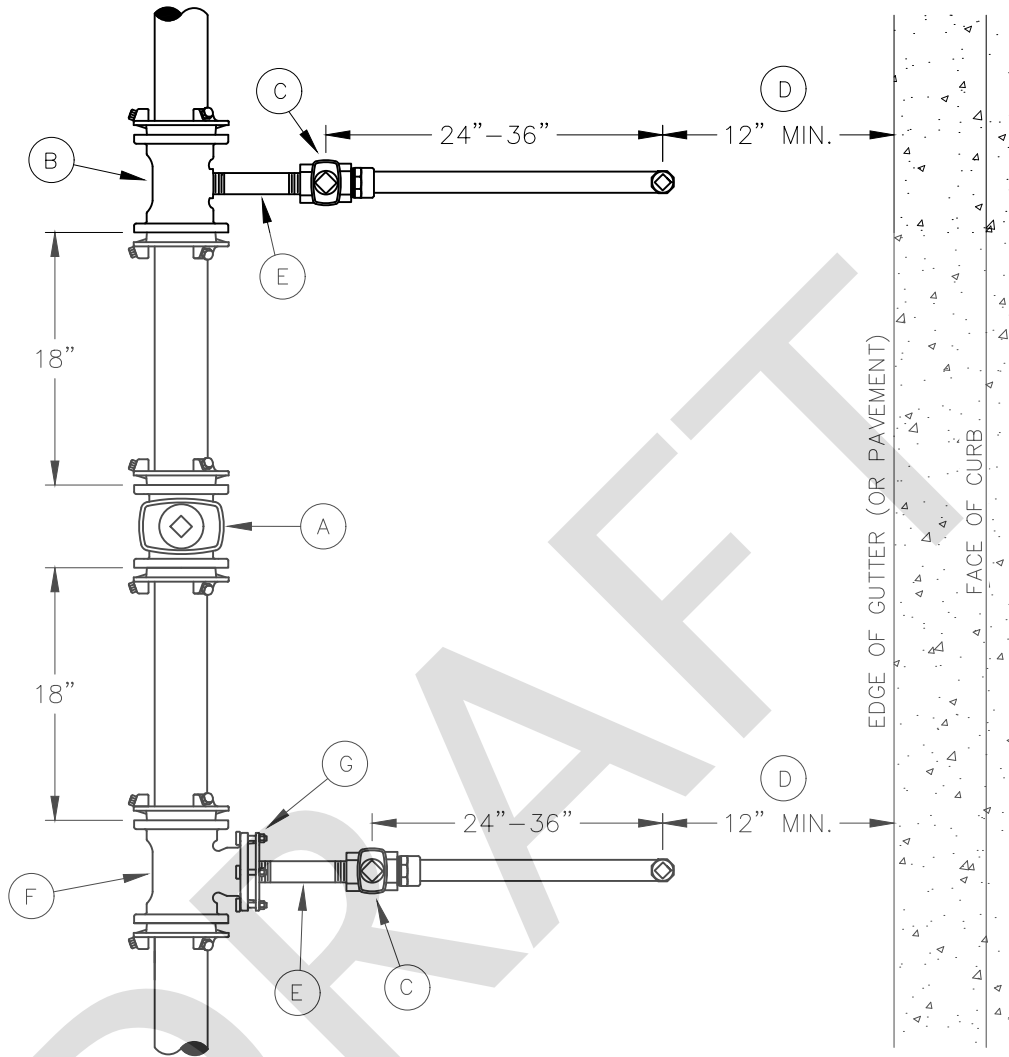

**KEYNOTES:**

- A. NORMALLY CLOSED VALVE. VALVE SIZE SHALL MATCH MAINLINE SIZE. REFER TO DETAIL 402 FOR VALVE BOX REQUIREMENTS.
- B. LINE-SIZE X 2" THREADED TEE.
- C. 2" BLOWOFF ASSEMBLY. REFER TO DETAIL 306 FOR REQUIREMENTS.
- D. MOVE TO OPPOSITE SIDE OF THE MAIN IF 12" MINIMUM CANNOT BE MAINTAINED.
- E. 2" X 6" BRASS NIPPLE.

**ALTERNATIVE METHOD:**

- F. LINE-SIZE X 4" MJ TEE.
- G. 4" MJ PLUG WITH 2" TAP.

N:\Standards\2024\Details\DWG\305\_2-Inch Blowoff Assembly at Normally Closed Pressure Zone Break.dwg, 6/13/2024 10:45:44 AM



**TUALATIN VALLEY  
WATER DISTRICT**

APPROVED BY  
PETER BOONE

DRAWING SCALE  
NONE

2" BLOWOFF ASSEMBLY  
AT NORMALLY CLOSED  
PRESSURE ZONE BREAK

EFF. DATE 07/01/24

STANDARD DETAIL

305

**NOTE:**

1. APPLICABLE TO DEAD END MAINS 8" AND SMALLER WHICH WILL NOT BE EXTENDED.
2. ADD CARV 18" UPSTREAM OF MJ CAP ON MAIN WATERLINE WHERE DEAD END IS LOCATED AT HIGH POINT.
3. BLOWOFF SHALL NOT BE INSTALLED UNDER ROAD BARRICADE SIGNS.

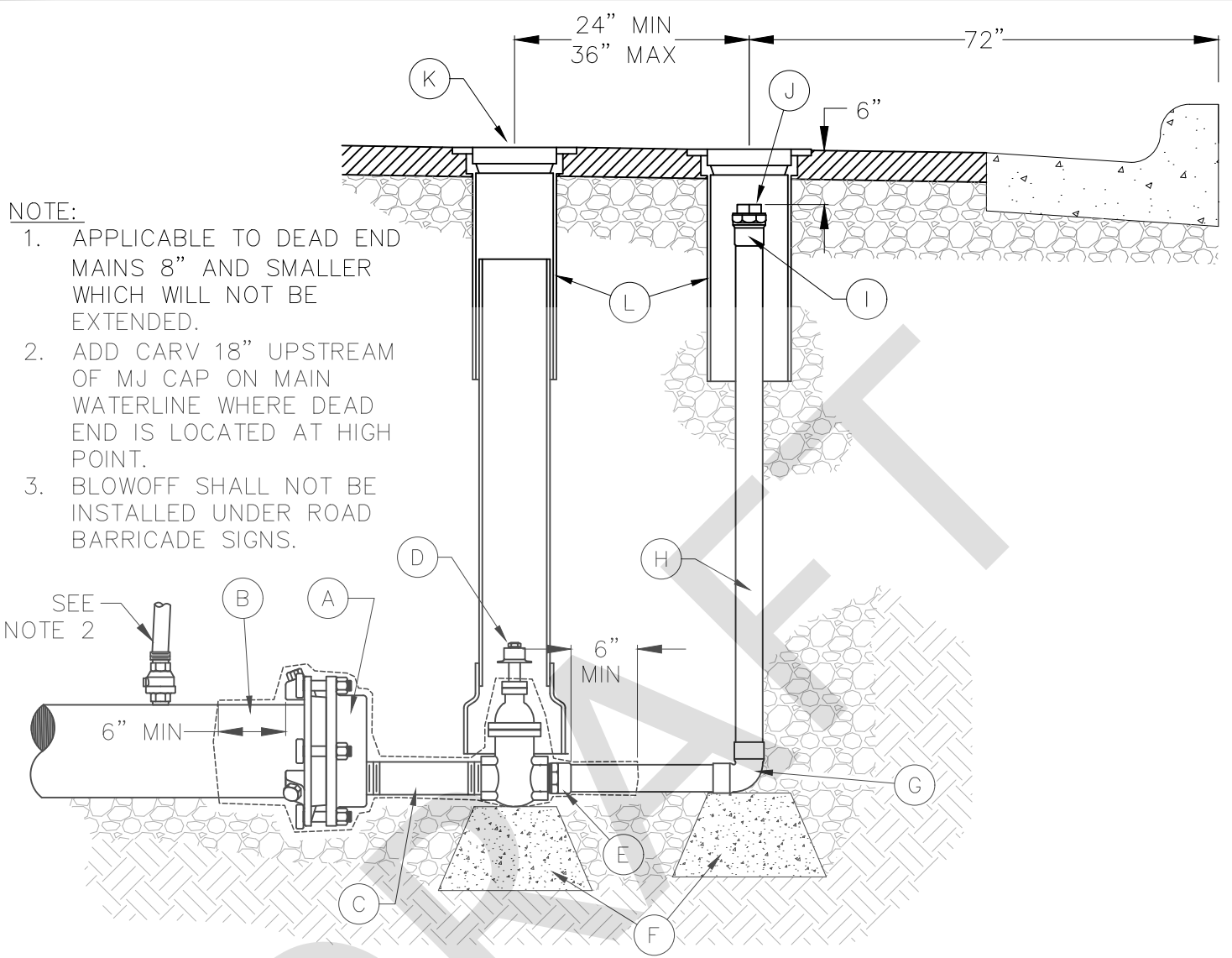

**KEYNOTES:**

- A. MJ CAP WITH OFFSET 2" TAP AT BOTTOM. TAP MAY BE CENTERED ON CAP FOR 4" MAINS.
- B. WRAP VALVE WITH POLYTHEYLENE ENCASEMENT. EXTEND 6" MINIMUM BEYOND VALVE AND CAP. SECURE TO PIPE WITH 10 MIL PVC PIPE WRAP TAPE. SEE DETAIL 301.
- C. 2" X 12" BRASS NIPPLE.
- D. 2" IRON BODY GATE VALVE WITH 2" OPERATOR NUT.
- E. 2" ADAPTER. COPPER MIPT TO SWEAT.
- F. 8" X 8" CONCRETE PIER BLOCK ON NATIVE SOIL.
- G. 2" 90° BEND, COPPER SLIP OR THREADED BRASS.
- H. 2" TYPE K RIGID COPPER TUBING OR THREADED BRASS PIPING, TYP.
- I. 2" ADAPTER. COPPER SWEAT TO FIPT.
- J. 2" BRASS PLUG HAND-TIGHT. USE FOOD GRADE GREASE ON PLUG THREADS.
- K. FINISHED GRADE. IF OUTSIDE THE PAVED AREA PROVIDE 4" THICK CONCRETE PAD OVER 4" COMPACTED 3/4"-0" CRUSHED ROCK. PAD SHALL EXTEND OF A MINIMUM OF 6" AROUND VALVE BOXES. REINFORCE CONCRETE WITH #4 REBAR MAX 12" O.C. CENTERED VERTICALLY IN SLAB. PROVIDE 3" CLEARANCE FROM EDGES AND PENETRATIONS. SEE DETAIL 402.
- L. VALVE BOX ASSEMBLY PER DETAILS 402 AND 403.

N:\Standards\2024\Details\DWG\306\_2-Inch Standard Blowoff (4- to 8-inch Mainline).dwg, 6/13/2024 10:45:58 AM



**TUALATIN VALLEY  
WATER DISTRICT**

APPROVED BY  
PETER BOONE

DRAWING SCALE  
NONE

2" STANDARD BLOWOFF  
(4" TO 8" MAINLINE)

EFF. DATE 07/01/24

STANDARD DETAIL

306

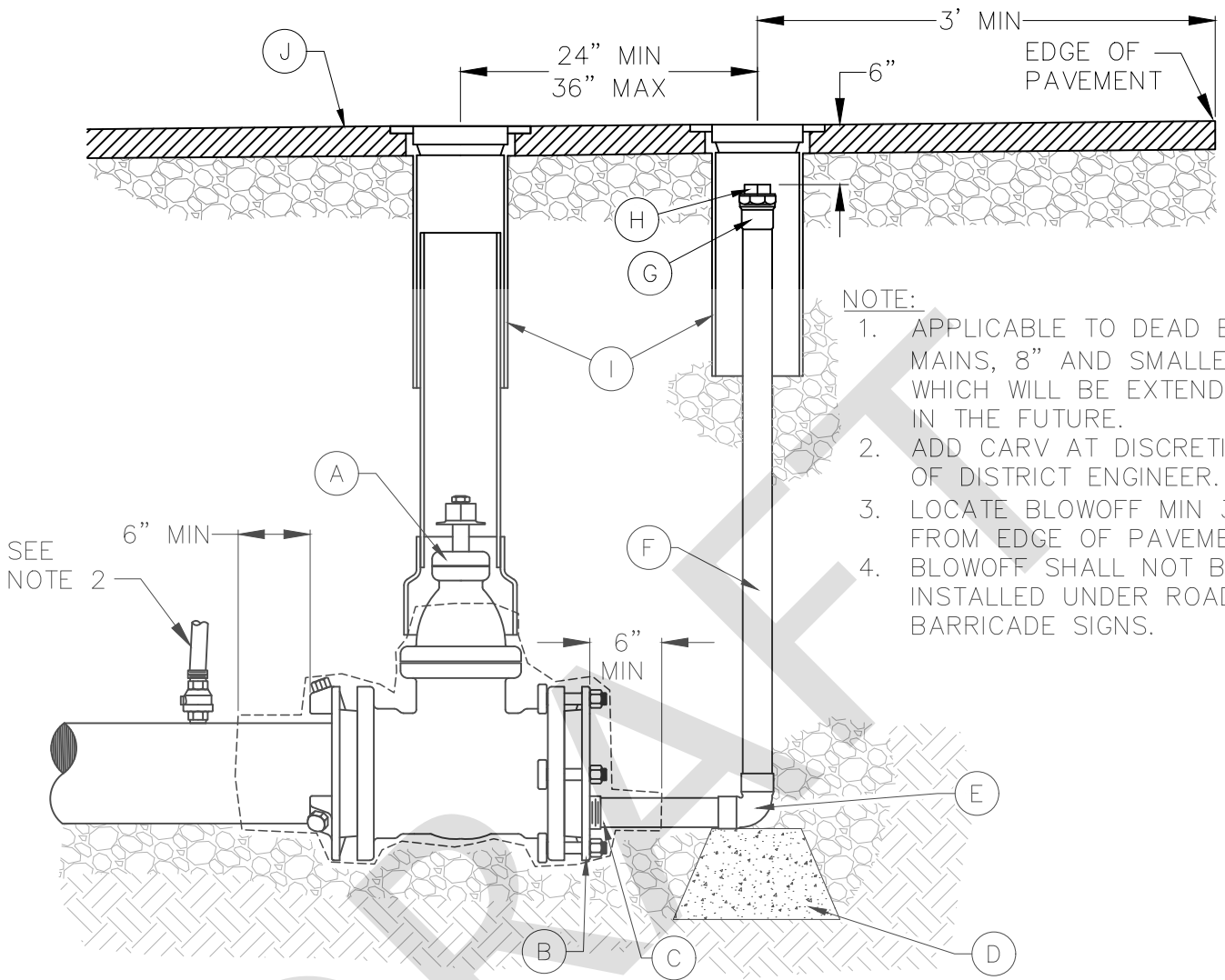

**NOTE:**

1. APPLICABLE TO DEAD END MAINS, 8" AND SMALLER, WHICH WILL BE EXTENDED IN THE FUTURE.
2. ADD CARV AT DISCRETION OF DISTRICT ENGINEER.
3. LOCATE BLOWOFF MIN 3' FROM EDGE OF PAVEMENT.
4. BLOWOFF SHALL NOT BE INSTALLED UNDER ROAD BARRICADE SIGNS.

**KEYNOTES:**

- A. LINE SIZE GATE VALVE. WRAP VALVE WITH POLYTHEYLENE ENCASEMENT. EXTEND 6" MINIMUM BEYOND VALVE AND SECURE TO PIPE WITH 10 MIL PVC PIPE TAPE. SEE DETAIL 301.
- B. MJ PLUG WITH OFFSET 2" TAP AT BOTTOM. TAP MAY BE CENTERED ON MJ PLUG FOR 4" MAINS.
- C. 2" ADAPTER. MIPT TO COPPER SWEAT OR THREADED BRASS.
- D. 8" X 8" CONCRETE PIER BLOCK ON NATIVE SOIL.
- E. 2" 90° BEND COPPER SLIP OR THREADED BRASS.
- F. 2" TYPE K RIGID COPPER TUBING OR THREADED BRASS PIPING, TYP.
- G. 2" ADAPTER. COPPER SWEAT TO FIPT.
- H. 2" BRASS PLUG HAND-TIGHT. USE FOOD GRADE GREASE ON PLUG THREADS.
- I. VALVE BOX ASSEMBLY PER DETAIL 402 AND 403.
- J. FINISHED GRADE. IF OUTSIDE THE PAVED AREA PROVIDE 4" THICK CONCRETE PAD OVER 4" COMPACTED 3/4"-0" CRUSHED ROCK. PAD SHALL EXTEND OF A MINIMUM OF 6" AROUND VALVE BOXES. REINFORCE CONCRETE WITH #4 REBAR MAX 12" O.C. CENTERED VERTICALLY IN SLAB. PROVIDE 3" CLEARANCE FROM EDGES AND PENETRATIONS. SEE DETAIL 402.

N:\Standards\2024\Details\DWG\307\_Phase Break End for Future Extension (4- to 8-inch Mainline).dwg, 6/13/2024 10:36:25 AM



**TUALATIN VALLEY  
WATER DISTRICT**

APPROVED BY  
PETER BOONE

DRAWING SCALE  
NONE

PHASE BREAK END FOR  
FUTURE EXTENSION  
(4" TO 8" MAINLINE)

EFF. DATE 07/01/24

STANDARD DETAIL  
**307**

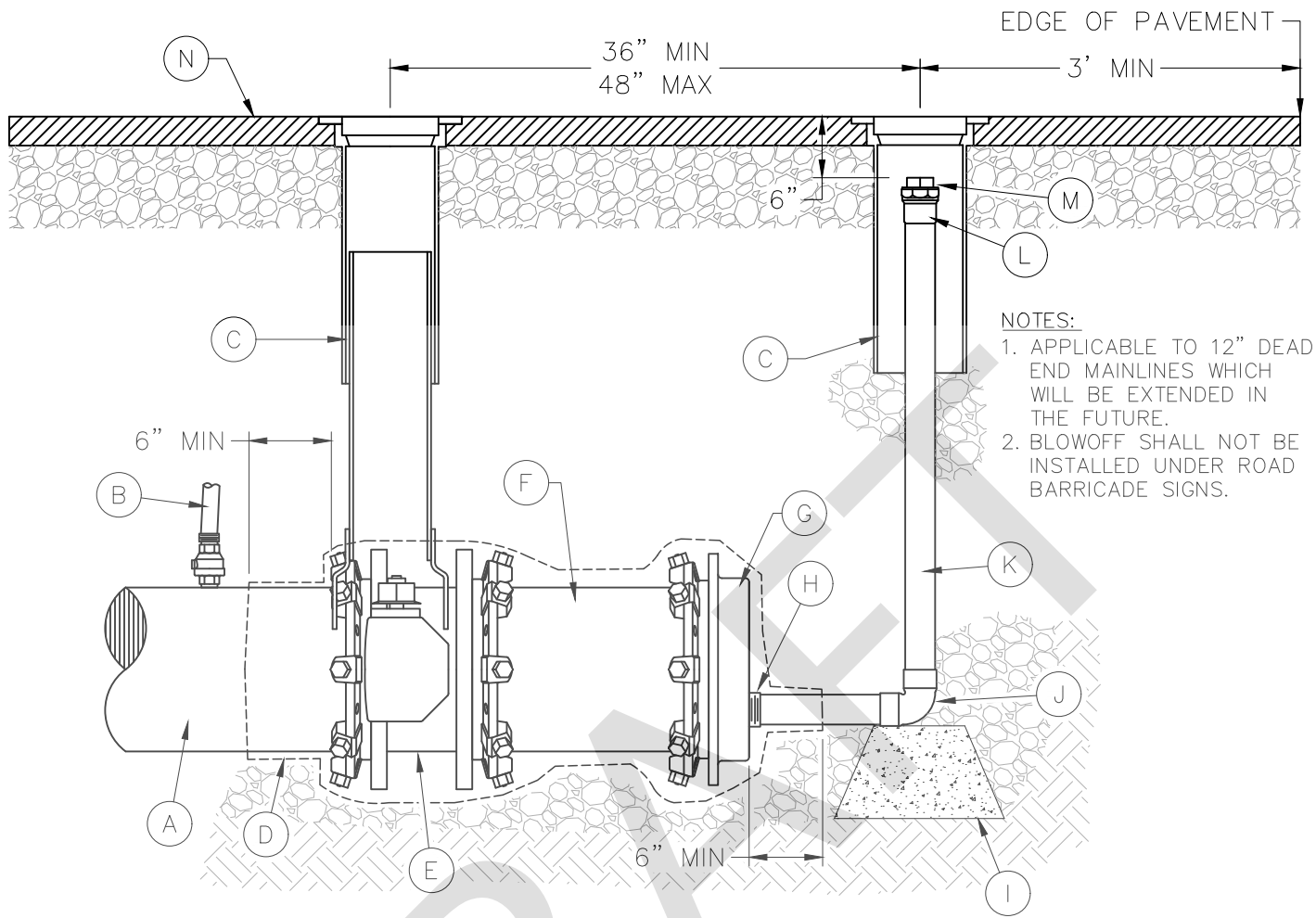

**NOTES:**  
 1. APPLICABLE TO 12" DEAD END MAINLINES WHICH WILL BE EXTENDED IN THE FUTURE.  
 2. BLOWOFF SHALL NOT BE INSTALLED UNDER ROAD BARRICADE SIGNS.

**KEYNOTES:**

- A. 12" DUCTILE IRON PIPE.
- B. ADD COMBINATION AIR AND VACUUM VALVE 18" UPSTREAM OF BUTTERFLY VALVE WHERE DEAD END IS LOCATED AT HIGH POINT PER DETAIL 405.
- C. VALVE BOX ASSEMBLY PER DETAIL 402 AND 403.
- D. WRAP VALVE, SPOOL, AND CAP WITH POLYETHYLENE ENCASUREMENT. EXTEND 6" MIN. BEYOND AS SHOWN.
- E. 12" MJ BUTTERFLY VALVE.
- F. 12" DUCTILE IRON PIPE SPOOL, 24" LONG.
- G. 12" MJ CAP WITH 2" OFFSET TAP.
- H. 2" ADAPTER, MIPT X COPPER SWEAT OR THREADED BRASS.
- I. 8" X 8" CONCRTE PIER BLOCK ON NATIVE SOIL.
- J. 2" 90° BEND, COPPER SLIP OR THREADED BRASS.
- K. 2" TYPE K RIGID COPPER OR THREADED BRASS PIPING, TYP.
- L. 2" ADAPTER, COPPER SWEAT X FIPT
- M. 2" BRASS PLUG. HAND TIGHTEN. USE FOOD GRADE GREASE ON PLUG THREADS.
- N. FINISHED GRADE. IF OUTSIDE THE PAVED AREA PROVIDE 4" THICK CONCRETE PAD OVER 4" COMPACTED 3/4"-0" CRUSHED ROCK. PAD SHALL EXTEND OF A MINIMUM OF 6" AROUND VALVE BOXES. REINFORCE CONCRETE WITH #4 REBAR MAX 12" O.C. CENTERED VERTICALLY IN SLAB. PROVIDE 3" CLEARANCE FROM EDGES AND PENETRATIONS. SEE DETAIL 402.

N:\Standards\2024\Details\DWG 308\_Phase Break End for Future Extension (12-inch Mainline).dwg, 6/13/2024 10:37:13 AM



**TUALATIN VALLEY**  
**WATER DISTRICT**

APPROVED BY  
 PETER BOONE

DRAWING SCALE  
 NONE

PHASE BREAK END FOR  
 FUTURE EXTENSION  
 (12" MAINLINE)

EFF. DATE 07/01/24

STANDARD DETAIL

308

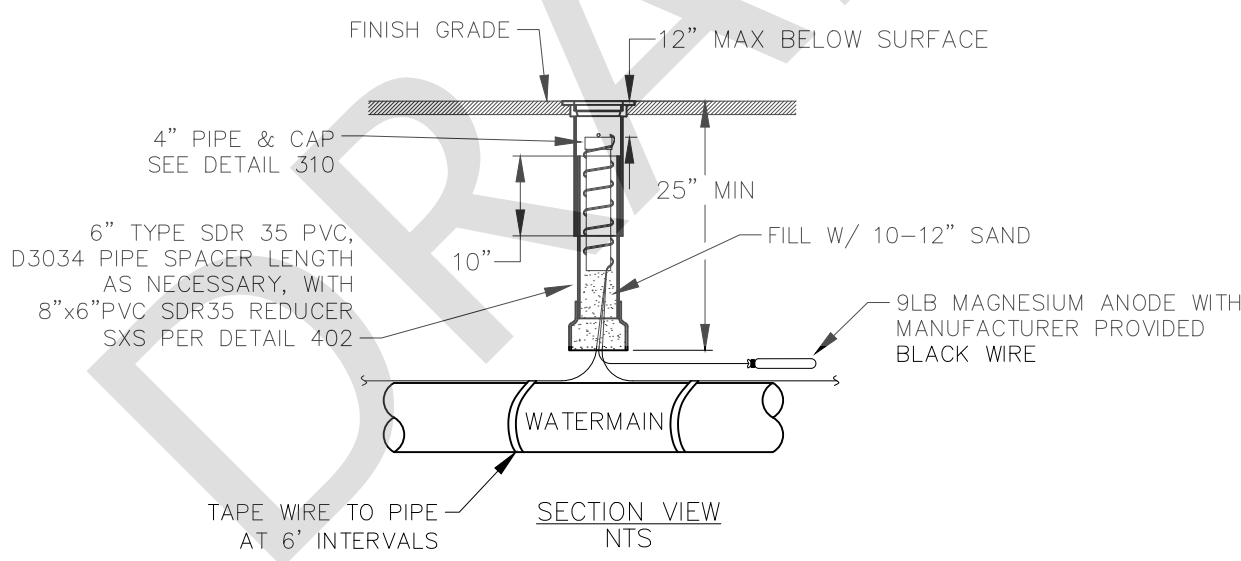
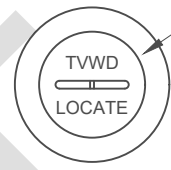
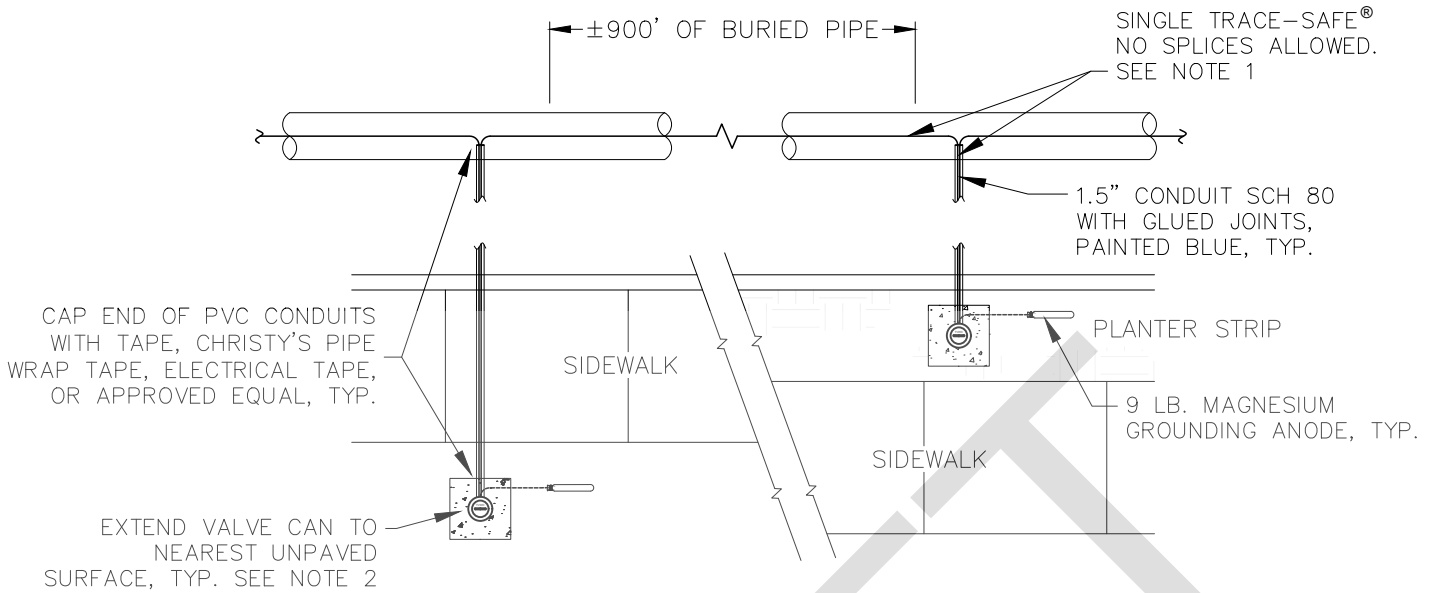

- NOTES:**
1. TRACING WIRE TO BE SINGLE CONTINUOUS LENGTH OF WIRE BETWEEN LOCATE STATIONS. IF SPLICE IS NEEDED, TVWD APPROVAL IS REQUIRED.
  2. PROVIDE CONCRETE PAD AROUND VALVE BOX IF LOCATED OUTSIDE OF PAVED AREAS PER STANDARD DETAIL 402.
  3. CONDUIT SWEEPS ARE NOT PERMITTED AT VALVE CANS.
  4. INSTALLATION OF CONDUIT UNDER CURB AND SIDEWALK SHALL UTILIZE TRENCHLESS METHOD(S).
  5. INSTALL ON MAINS DEEPER THAN 5 FEET REGARDLESS OF SIZE. TRACER WIRES SHALL NOT BE INSTALLED DEEPER THAN 8 FEET, FOR PIPES DEEPER THAN 8 FEET INSTALL TRACER WIRE ABOVE PIPE AT 8 FEET DEPTH.
  6. SEE STANDARD DETAIL 310 FOR ADDITIONAL WIRE DETAIL.

N:\Standards\2024\Details\DWG\309\_Locate Station.dwg, 6/13/2024 10:46:13 AM

 <b>TUALATIN VALLEY WATER DISTRICT</b>	APPROVED BY PETER BOONE	LOCATE STATION	EFF. DATE 07/01/24
	DRAWING SCALE NONE		STANDARD DETAIL <b>309</b>



TRACE-SAFE® TS-19-IL-LC-C  
LOCATING CLIP W/ CAP, TYP.  
(OR APPROVED EQUAL)

4" PVC CAP. SEE  
PLAN VIEW BELOW.,  
GLUE TO 4" PVC PIPE

CONNECT BLACK GROUND  
WIRE TO TRACE-SAFE®  
WIRE OR "PIG-TAIL" WITH  
TS-12-19-IL  
(OR APPROVED EQUAL)

LOOP TRACE-SAFE® AND  
BLACK GROUND WIRE  
AROUND 4" PVC PIPE

18"

4" PVC PIPE

BLACK WIRE TO  
GROUNDING ANODE

BLUE HDPE COATED 19 AWG  
TRACE-SAFE® TRACING WIRES,  
OR APPROVED EQUAL

SECTION VIEW

1/4" DRILLED VENT  
HOLE (2)

1/4" EYE BOLT

PLAN VIEW  
4" PVC CAP

NOTES:

1. FOR END OF TRACER WIRE RUN, ONLY INCLUDE ONE TRACER WIRE AND ONE ANODE WIRE.

N:\Standards\2024\Details\DWG\310\_Locate Station Closeup.dwg, 6/13/2024 10:46:26 AM



**TUALATIN VALLEY**  
WATER DISTRICT

APPROVED BY  
PETER BOONE

DRAWING SCALE  
NONE

LOCATE STATION CLOSEUP

EFF. DATE 07/01/24

STANDARD DETAIL

310

N:\Standards\2024\Details\DWG\311\_Locate Station Placement.dwg, 6/13/2024 10:46:40 AM

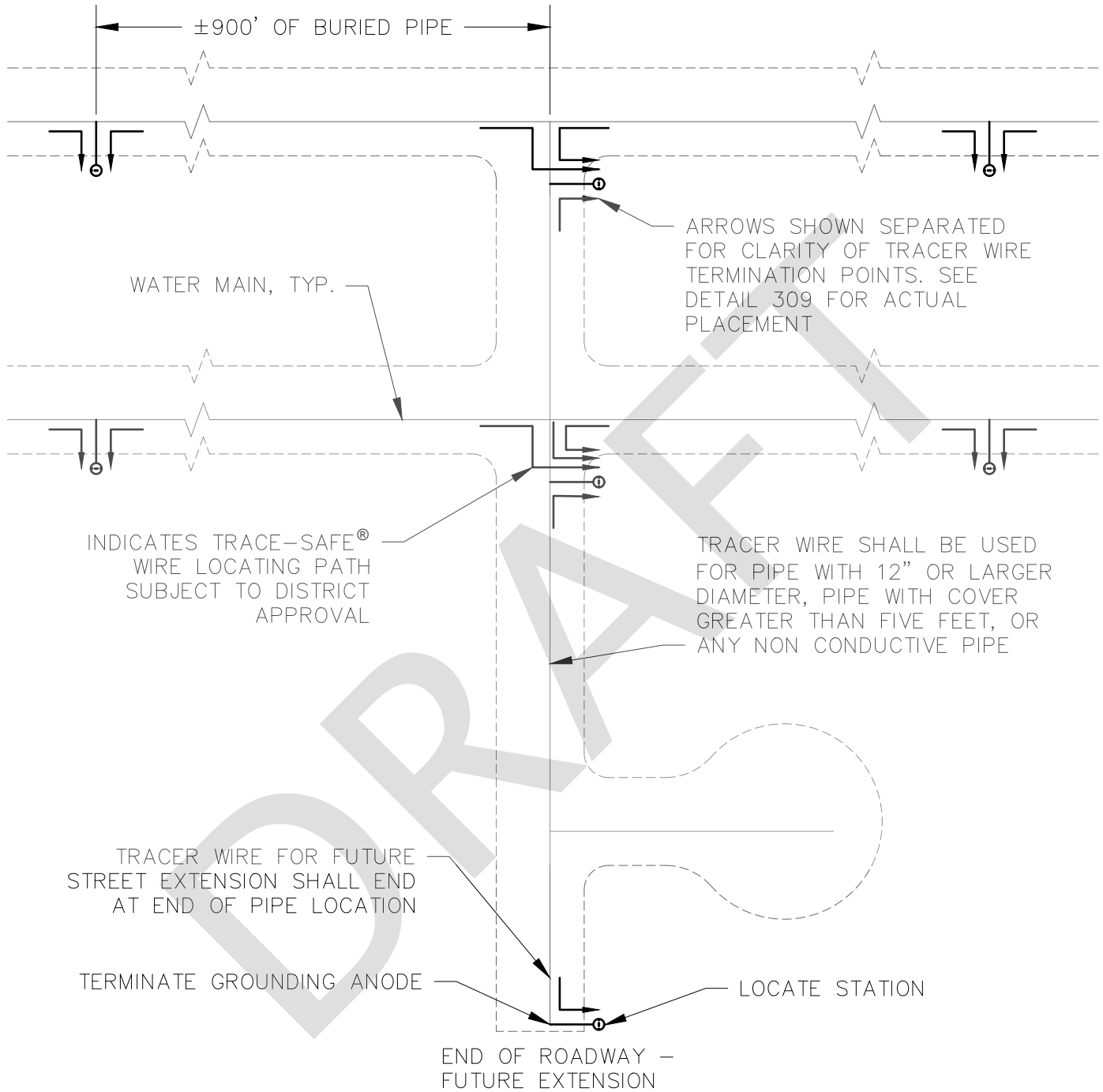

**NOTES:**

1. WHEN CONNECTING TO EXISTING PIPE WITHOUT EXISTING LOCATE WIRE, INSTALL LOCATE STATION AT START OF NEW PIPING.
2. LOCATE STATION WIRE IS PREFERRED TO BE IN THE SAME TRENCH AS SERVICES OR HYDRANT PIPING WHERE POSSIBLE.



**TUALATIN VALLEY**  
WATER DISTRICT

APPROVED BY  
PETER BOONE

DRAWING SCALE  
NONE

LOCATE STATION PLACEMENT

EFF. DATE 07/01/24

STANDARD DETAIL

311

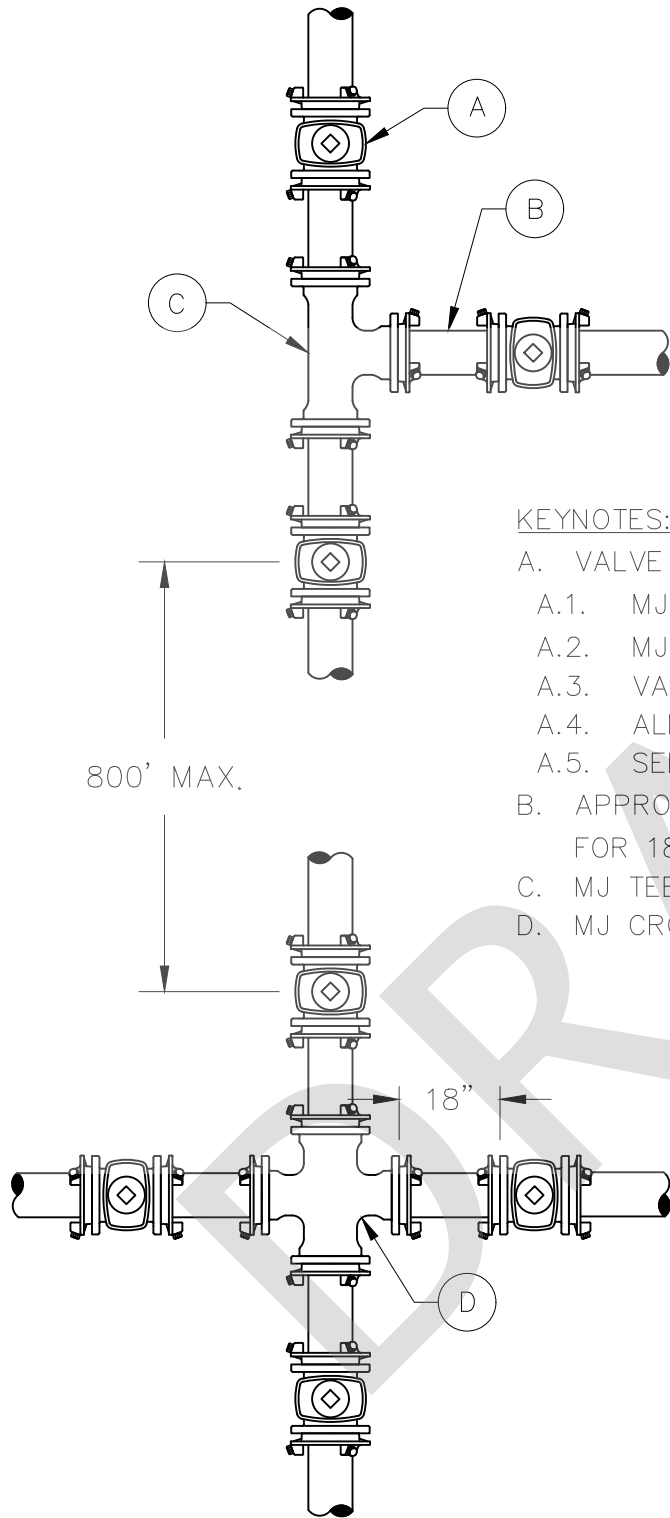

KEYNOTES:

- A. VALVE (TYP)
  - A.1. MJ GATE VALVES 8" AND SMALLER.
  - A.2. MJ BUTTERFLY VALVES 12" AND LARGER.
  - A.3. VALVE SIZE SHALL MATCH MAINLINE SIZE.
  - A.4. ALL JOINTS SHALL BE RESTRAINED.
  - A.5. SEE DETAIL 402 FOR VALVE BOX REQUIREMENTS.
- B. APPROXIMATELY 24" SPOOL REQUIRED TO ALLOW FOR 18" SPACING BETWEEN FITTINGS.
- C. MJ TEE.
- D. MJ CROSS.

NOTES:

1. VALVES SHALL BE INSTALLED PER DETAIL 402.
2. ALL VALVES SHALL BE WRAPPED IN POLYETHYLENE PER DETAIL 402.
3. BUTTERFLY VALVE OPERATOR NUTS SHALL BE ORIENTED ON THE NORTH OR EAST SIDE OF THE MAIN.



**TUALATIN VALLEY**  
WATER DISTRICT

APPROVED BY  
PETER BOONE

DRAWING SCALE  
NONE

TYPICAL WATER VALVE  
LOCATION

EFF. DATE 07/01/24

STANDARD DETAIL

401

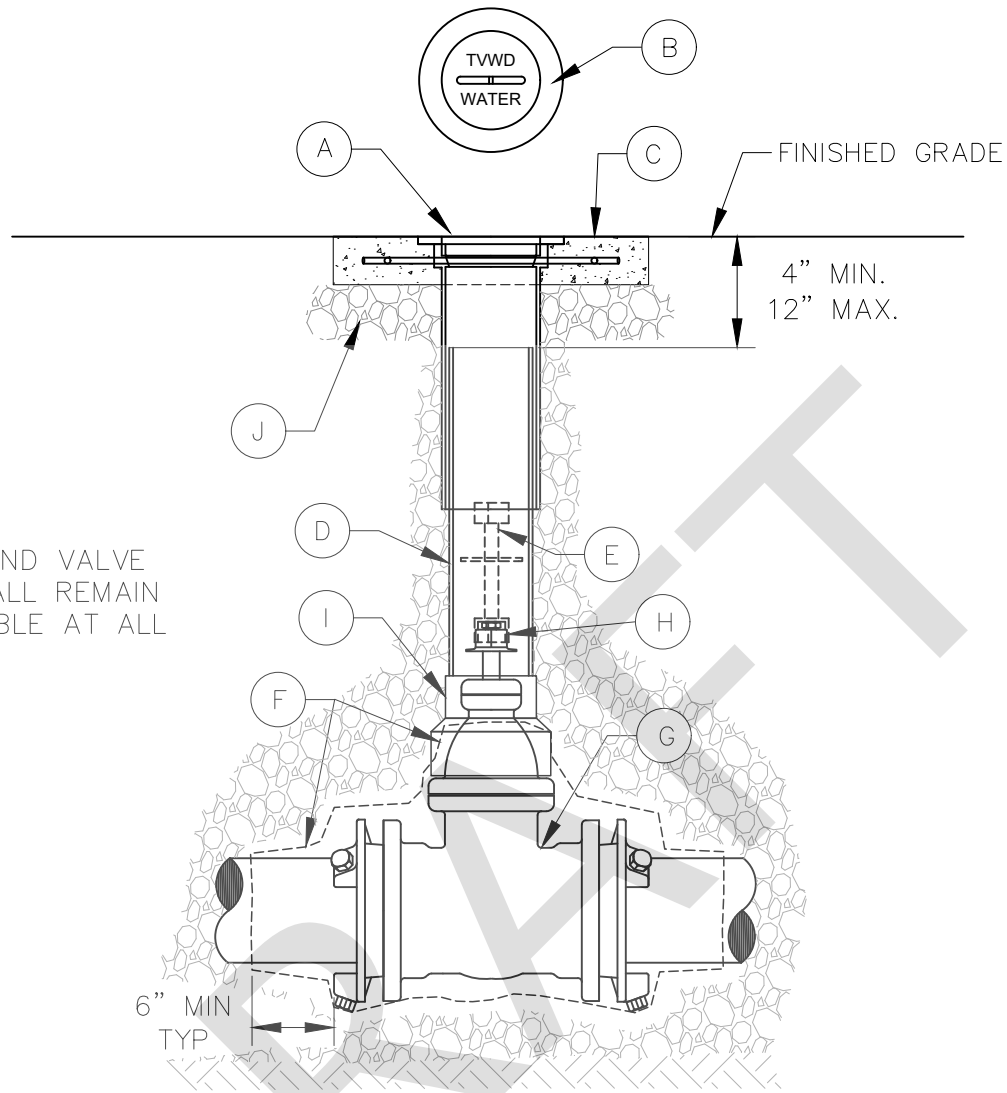

**NOTES:**

1. VALVE AND VALVE BOX SHALL REMAIN ACCESSIBLE AT ALL TIMES.

**KEYNOTES:**

- A. EAST JORDAN MODEL #3639Z1 VALVE BOX, OR APPROVED EQUAL. VALVE BOX SHALL BE PLUMB, CENTERED ON AXIS OF OPERATING NUT, AND NOT REST ON OPERATING ASSEMBLY.
- B. EAST JORDAN MODEL #3639A1 COVER. FOR PEDESTRIAN HARD SURFACE AREAS, EAST JORDAN MODEL #3639A2 COVER SHALL BE USED. CAST "TVWD WATER" IN TOP SURFACE OF COVER.
- C. UNPAVED AREAS ONLY: PROVIDE 4" THICK CONCRETE PAD OVER 4" COMPACTED 3/4"-0" CRUSHED ROCK. PAD SHALL EXTEND OF A MINIMUM OF 6" AROUND VALVE BOXES. REINFORCE CONCRETE WITH #4 REBAR MAX 12" O.C. CENTERED VERTICALLY IN SLAB. PROVIDE 3" CLEARANCE FROM EDGES AND PENETRATIONS.
- D. 6" TYPE SDR 35 PVC, D3034 PIPE SPACER. LENGTH AS NECESSARY.
- E. OPERATOR EXTENSION REQUIRED WHEN VALVE NUT IS 60" OR DEEPER FROM FINISHED GRADE. SEE STANDARD DETAIL 403.
- F. WRAP VALVE WITH POLYETHYLENE ENCASEMENT PRIOR TO BACKFILLING. EXTEND POLYETHYLENE 6" MINIMUM BEYOND VALVE AND SECURE TO PIPE WITH 10-MIL ADHESIVE PVC PIPE TAPE. SEE STANDARD DETAIL 301.
- G. VALVES 8" AND SMALLER SHALL BE MJ GATE VALVES. VALVES 12" AND LARGER SHALL BE MJ BUTTERFLY VALVES.
- H. 2" SQUARE OPERATING NUT.
- I. 8" X 6" PVC SDR35 REDUCER SXS, CONNECT TO D3034 PIPE USING A COMPATIBLE PVC CEMENT.
- J. COMPACTED ROCK.

N:\Standards\2024\DWG\402\_Typical Valve Setting.dwg, 6/13/2024 10:47:49 AM



**TUALATIN VALLEY**  
WATER DISTRICT

APPROVED BY  
PETER BOONE

DRAWING SCALE  
NONE

TYPICAL VALVE SETTING

EFF. DATE 07/01/24

STANDARD DETAIL

402

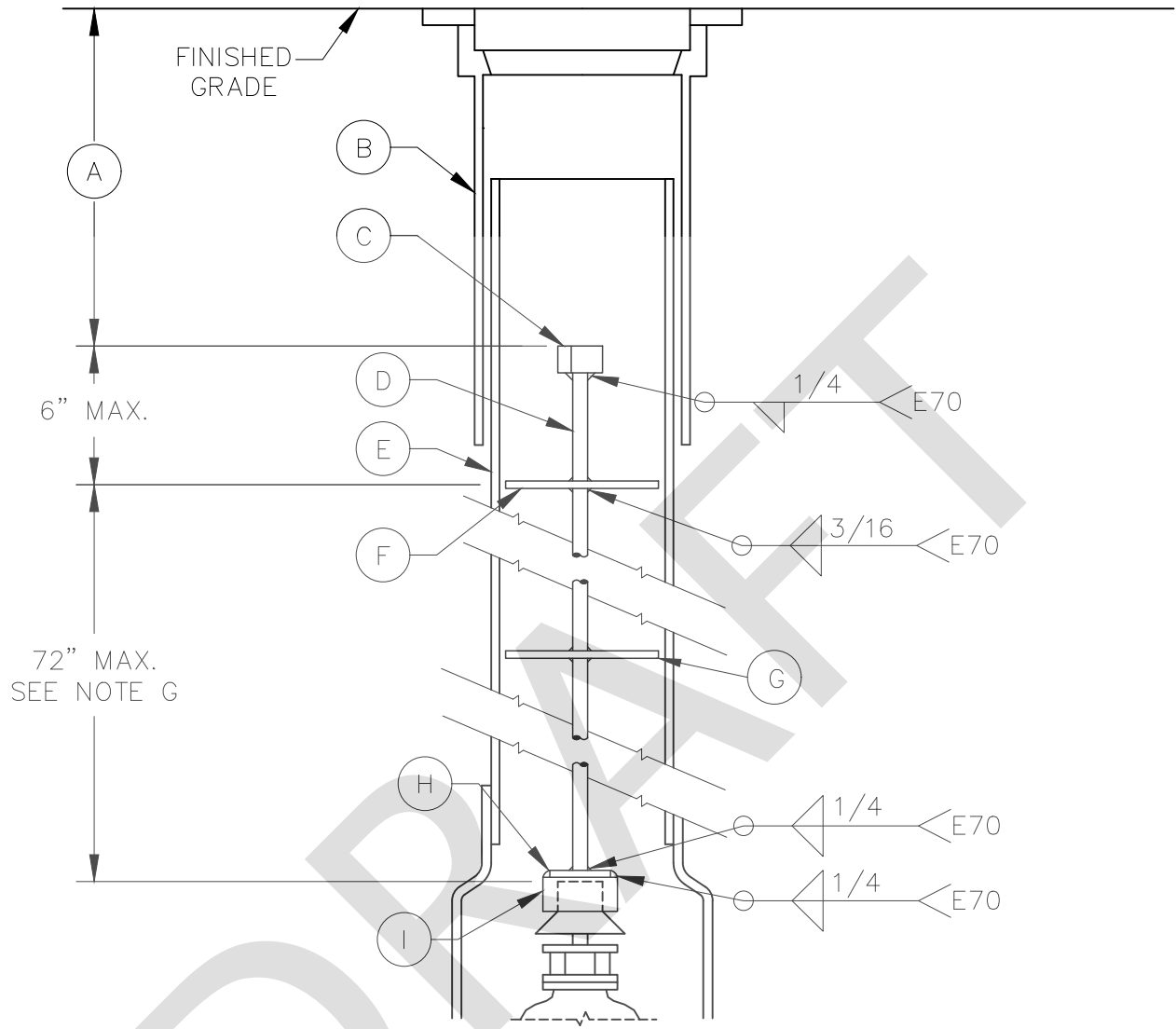

**KEYNOTES:**

- A. EXTEND 2" OPERATOR NUT TO 18" FROM FINISHED GRADE WHEN VALVE NUT IS 60" OR DEEPER FROM FINISHED GRADE.
- B. VALVE BOX PER DETAIL 402.
- C. 2" SQUARE OPERATOR NUT.
- D. 1" MINIMUM SOLID STOCK A36 STEEL (SQUARE). VALVE OPERATOR EXTENSION SHALL BE HOT DIPPED GALVANIZED AFTER FABRICATION.
- E. 6" SDR 35 PVC D3034 PIPE SPACER. LENGTH AS NECESSARY.
- F. ROCK GUARD. 1/8" STEEL PLATE WELDED TO SOLID SHAFT. GUARD SHALL BE 3/8" SMALLER THAN INSIDE DIAMETER OF PIPE SPACER.
- G. SECONDARY ROCK GUARD IS REQUIRED IF DISTANCE FROM UPPER ROCK GUARD TO VALVE NUT EXCEEDS 72". INSTALL SECONDARY GUARD HALFWAY BETWEEN UPPER GUARD AND VALVE NUT.
- H. 2-1/2" X 2-1/2" X 3/8" STEEL FLAT BAR.
- I. 3"X3" X 3/8" X 2" LONG STEEL SQUARE TUBE.

N:\Standards\2024\Details\DWG\403\_Valve Operator Extension.dwg, 6/13/2024 10:48:03 AM



**TUALATIN VALLEY  
WATER DISTRICT**

APPROVED BY  
PETER BOONE

DRAWING SCALE  
NONE

VALVE OPERATOR  
EXTENSION

EFF. DATE 07/01/24

STANDARD DETAIL

403

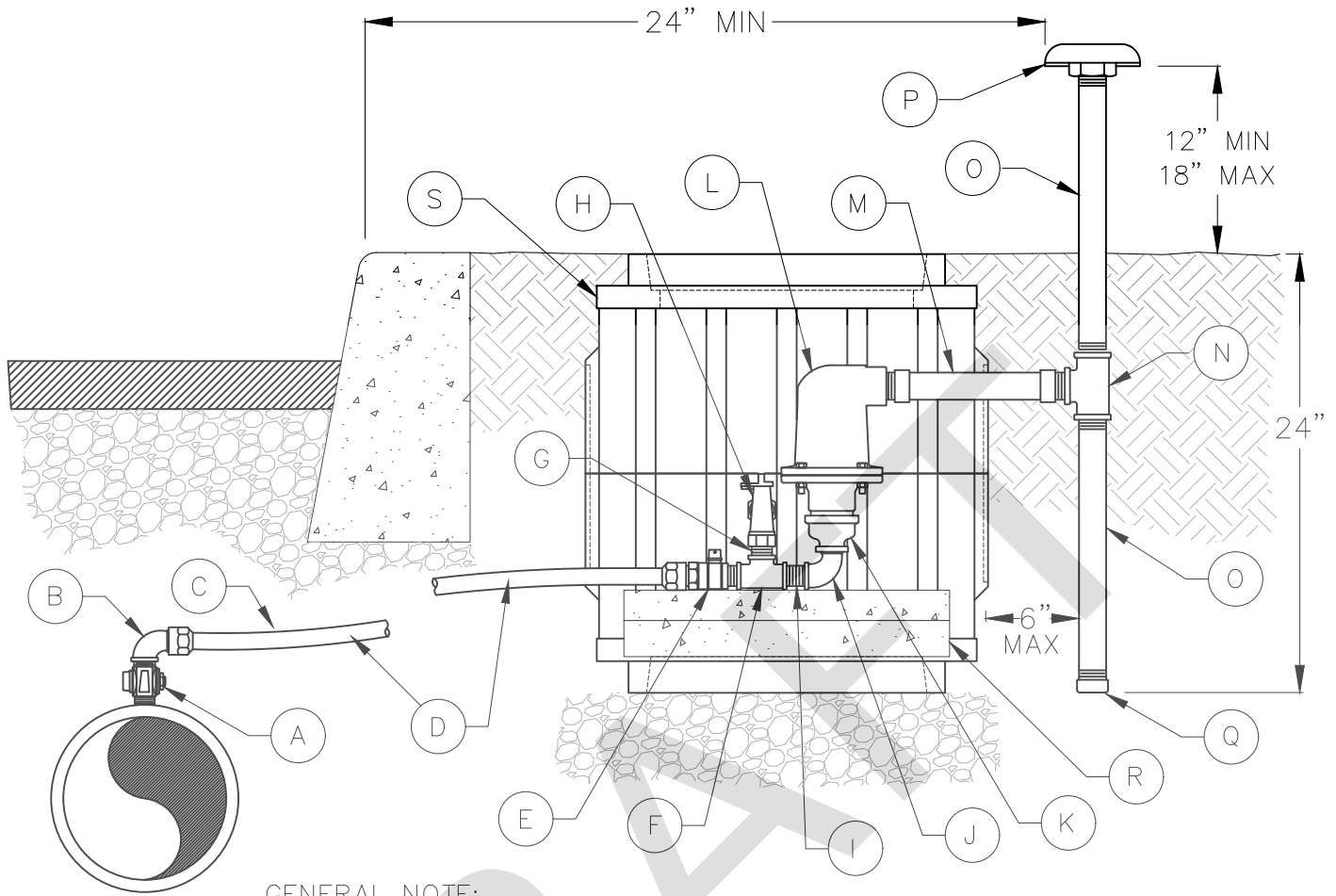

**GENERAL NOTE:**

1. FOR USE ON 8" AND SMALLER DIAMETER WATER MAINS.
2. ADD CARV 12" UPSTREAM OF GATE VALVE WHERE DEAD END IS LOCATED AT HIGH POINT

**KEYNOTES:**

- |  |   |
|--|---|
| <p>A. 1" CORPORATION STOP, CC X MIPT. DIRECT TAP DI PIPE.</p> <p>B. 1" 90° BEND, FIPT X COPPER COMPRESSION.</p> <p>C. TAPE WRAP COPPER SERVICE, SEE STANDARD DETAIL 602.</p> <p>D. 1" TYPE K SOFT COPPER TUBING SLOPED AT 1% MINIMUM UP FROM MAIN.</p> <p>E. 1" BALL CURB STOP VALVE, COMPRESSION X MIPT</p> <p>F. 1" BRASS TEE</p> <p>G. 1" CLOSE BRASS NIPPLE</p> <p>H. 1" BRASS BALL VALVE, FIPT</p> <p>I. 1" X 4" BRASS NIPPLE</p> <p>J. 1" BRASS STREET ELL</p> <p>K. 2" X 1" BRASS REDUCER</p> | <p>L. 2" COMBINATION AIR VALVE. ARI MODEL D-040-C-2</p> <p>M. 1-1/2" SCHEDULE 40 PVC WITH SLIP X MIPT ENDS</p> <p>N. 1-1/2" GALVANIZED TEE</p> <p>O. 1-1/2" GALVANIZED VENT PIPE</p> <p>P. 1-1/2" MORRIS BROS FIG 155 "DOUBLE OUTLET VENT"</p> <p>Q. 1-1/2" GALVANIZED CAP</p> <p>R. 2 ~ 2" X 8" X 16" PRECAST CONCRETE BLOCKS</p> <p>S. 2 ~ ARMORCAST MODEL P6000485 (OR APPROVED EQUAL) METER BOXES AND ARMORCAST MODEL A6000484R CONCRETE COVER STACKED TOGETHER. LOCATION SIMILAR TO WATER METERS IN DETAILS 603 OR 604. SET METER BOX OVER 12" DRAIN ROCK.</p> |
|--|---|



APPROVED BY  
PETER BOONE

DRAWING SCALE  
NONE

2" COMBINATION AIR AND  
VACUUM VALVE  
(1" SERVICE)

EFF. DATE 07/01/24

STANDARD DETAIL  
404

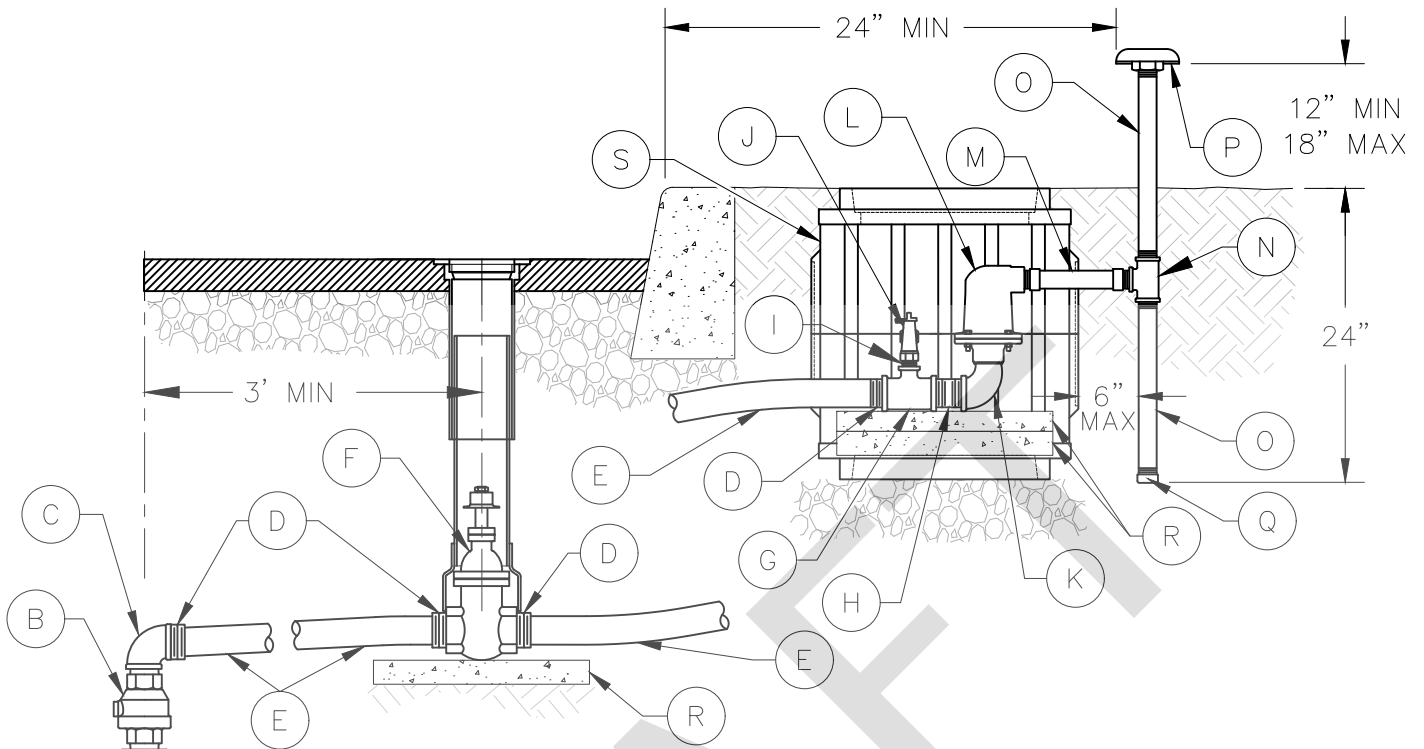

**GENERAL NOTE:**

1. FOR USE ON 12" DIAMETER WATER MAINS.
2. ADD CARV 12" UPSTREAM OF GATE VALVE WHERE DEAD END IS LOCATED AT HIGH POINT

**KEYNOTES**

- A. 2" DOUBLE STRAP SERVICE SADDLE.
- B. 2" BALL VALVE OR BALL VALVE TYPE CORP STOP, MIPT X MIPT.
- C. 2" BRASS 90° BEND, FIPT X FIPT.
- D. 2" BRASS COUPLING, COPPER COMPRESSION X MIPT.
- E. 2" TYPE K RIGID COPPER TUBING SLOPED AT 1% MINIMUM UP FROM MAIN. TAPE WRAP COPPER SERVICE, SEE DETAIL 602.
- F. 2" IRON BODY GATE VALVE WITH VALVE BOX, SEE DETAIL 402.
- G. 2" X 1" BRASS TEE
- H. 2" X 4" BRASS NIPPLE
- I. 1" CLOSE BRASS NIPPLE
- J. 1" BRASS BALL VALVE, FIPT
- K. 2" BRASS WITH FEMALE X FEMALE CONNECTION ELL.
- L. 2" COMBINATION AIR VALVE. ARI MODEL D-040-C-2.
- M. 1-1/2" SCHEDULE 40 PVC WITH SLIP X MIPT ENDS.
- N. 1-1/2" GALVANIZED TEE.
- O. 1-1/2" GALVANIZED VENT PIPE.
- P. 1-1/2" MORRISON BROS FIG. 155 "DOUBLE OUTLET VENT".
- Q. 1-1/2" GALVANIZED CAP.
- R. 2" X 8" X 16" PRECAST CONCRETE BLOCK.
- S. 2 ~ ARMORCAST MODEL P6000485 (OR APPROVED EQUAL) METER BOXES AND ARMORCAST MODEL A6000484R CONCRETE COVER STACKED TOGETHER OVER 12" DEPTH DRAIN ROCK.

N:\Standards\2024\Details\DWG\405\_2-inch Combination Air and Vacuum Valve.dwg, 6/13/2024 10:48:27 AM



**TUALATIN VALLEY**  
WATER DISTRICT

APPROVED BY  
PETER BOONE

DRAWING SCALE  
NONE

2" COMBINATION AIR  
AND VACUUM VALVE

EFF. DATE 07/01/24

STANDARD DETAIL

405

N:\Standards\2024\Details\DWG\501\_Typical Water Main and Fire Hydrant Location.dwg, 6/13/2024 10:49:33 AM

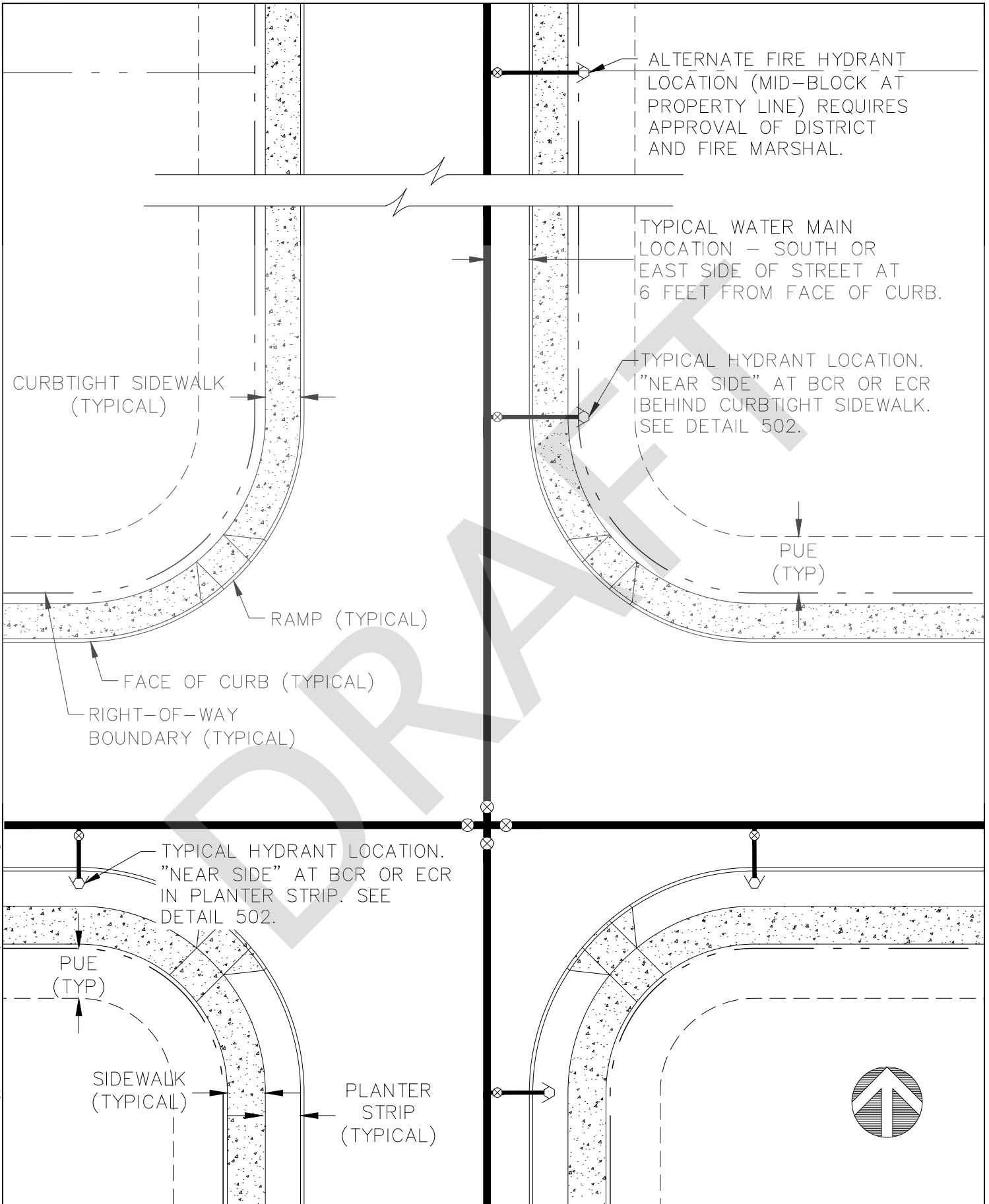

**TUALATIN VALLEY**  
WATER DISTRICT

APPROVED BY  
PETER BOONE

DRAWING SCALE  
NONE

TYPICAL WATER MAIN AND  
FIRE HYDRANT LOCATION

EFF. DATE 07/01/24

STANDARD DETAIL  
**501**



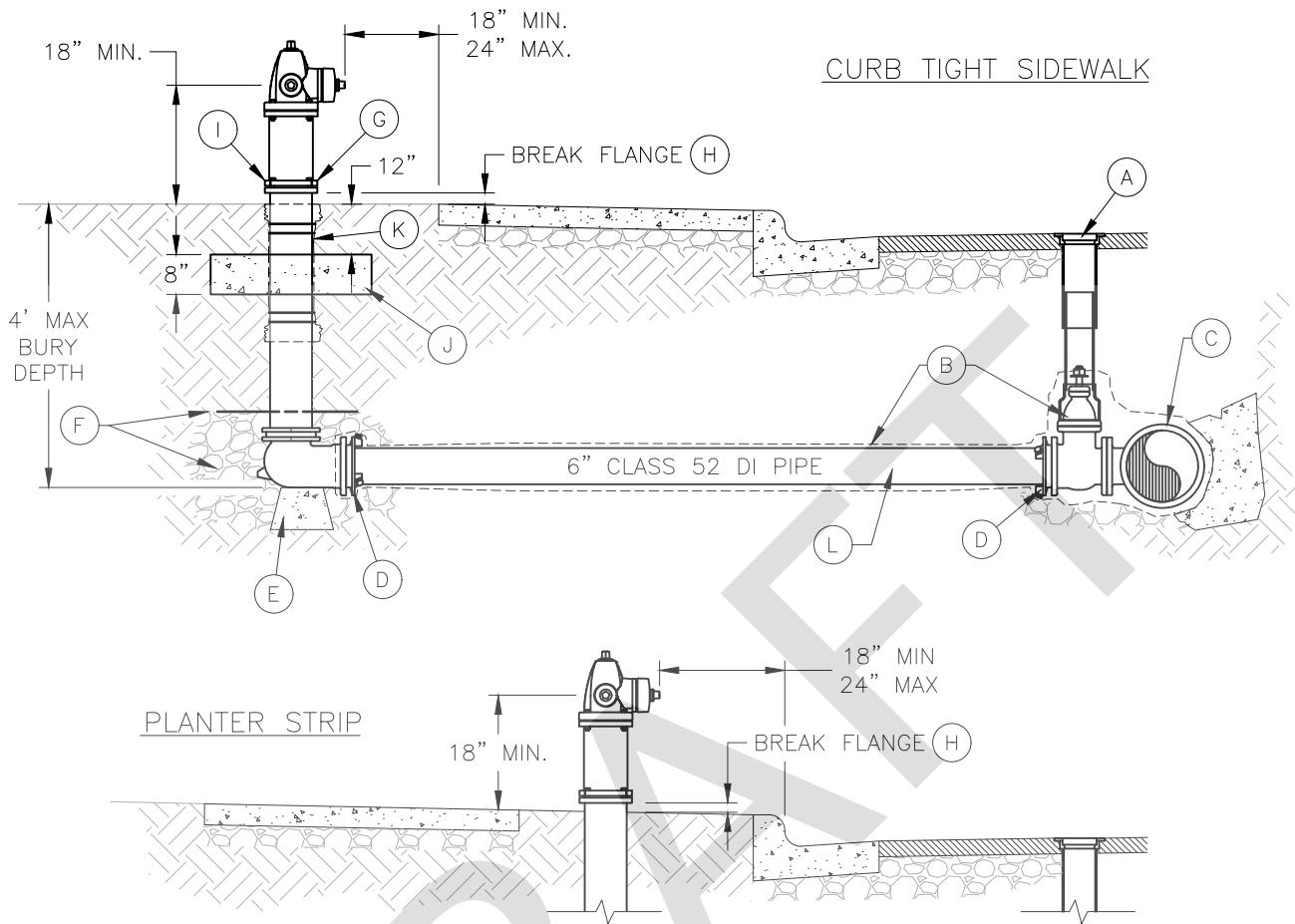

**KEYNOTES:**

- A. VALVE BOX ASSEMBLY PER STANDARD DETAIL 402.
- B. 6" GATE VALVE. WRAP TEE, VALVE, AND PIPE TO THE FOOT VALVE WITH POLYETHYLENE ENCASUREMENT PRIOR TO BACKFILLING. EXTEND ENCASUREMENT WRAP A MINIMUM OF 6" BEYOND TEE. SECURE TO PIPE WITH 10 MIL PVC PIPE WRAP TAPE. SEE STANDARD DETAIL 301. DO NOT WRAP HYDRANT BARREL.
- C. TEE. NEW CONSTRUCTION TEE SHALL BE MJ X MJ X FLG. CONNECTIONS TO EXISTING MAINS SHALL BE TAPPING TEE PER STANDARD DETAIL 302. THRUST BLOCK REQUIRED ONLY FOR TAPPING TEE.
- D. MECHANICAL JOINT WITH GRIP FOLLOWER, TYP. ALL JOINTS IN HYDRANT ASSEMBLY SHALL BE FULLY RESTRAINED.
- E. 12" X 12" X 8" CONCRETE PIER BLOCK ON UNDISTURBED NATIVE SOIL.
- F. 1-1/2" CLEAN DRAIN ROCK POCKET. 4 CUBIC FEET MINIMUM. MINIMUM 6" ABOVE HYDRANT DRAIN OPENING. PLACE GEOTEXTILE FABRIC OVER TOP DRAIN ROCK TO RESTRICT SOIL FROM MIGRATING INTO DRAIN ROCK POCKET.
- G. MAINTAIN MINIMUM CLEAR SPACE IN ALL DIRECTIONS PER STANDARD DETAIL 503. PLACEMENT OF CONCRETE AROUND HYDRANTS IS PROHIBITED.
- H. FOLLOW MANUFACTURER RECOMMENDATIONS FOR BURY LINE. BREAK FLANGE SHALL BE A MINIMUM 3" AND A MAXIMUM OF 6" ABOVE FINISHED GRADE.
- I. NO RISER KITS ON NEW HYDRANT INSTALLATIONS.
- J. 24" X 24" X 8" CONCRETE BLOCK – 3500 PSI, 2" BELOW SCORE LINE, AND 12" BELOW BURY LINE. CONCRETE SHALL NOT IMPACT WEEP HOLE.
- K. WRAP HYDRANT BARREL WITH PE WRAP BENEATH BURY LINE TO 6 INCHES BELOW CONCRETE BLOCK. ENSURE PE WRAP DOES NOT INTERFERE WITH WEEP HOLE.
- L. ADD VERTICAL BENDS TO MAINTAIN 4' MAX BURY DEPTH.

N:\Standards\2024\Details\DWG\502\_Fire Hydrant Standard Installation.dwg, 6/13/2024 10:49:48 AM



**TUALATIN VALLEY  
WATER DISTRICT**

APPROVED BY  
PETER BOONE

DRAWING SCALE  
NONE

FIRE HYDRANT  
STANDARD INSTALLATION

EFF. DATE 07/01/24

STANDARD DETAIL

502

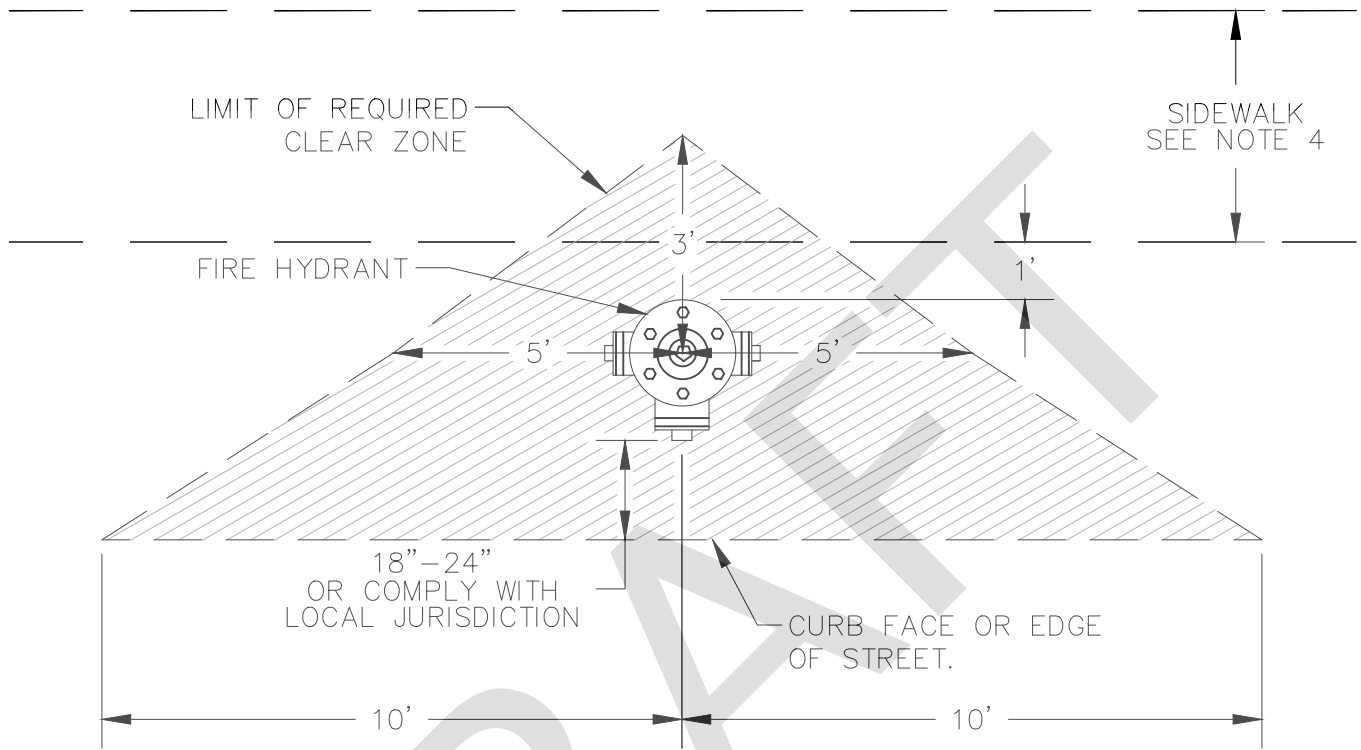

**NOTES:**

1. THE CLEAR ZONE PROHIBITS THE FOLLOWING:
  - VEHICLE PARKING
  - FENCES
  - TREES
  - LARGE BUSHES
  - RETAINING WALLS
  - ANYTHING ELSE THAT MAY INTERFERE WITH OPERATION OF THE FIRE HYDRANT.
2. THE CLEAR ZONE ALLOWS THE FOLLOWING:
  - LAWN GRASS
  - MULCH
  - BARK DUST
  - GROUND COVER
  - LOW PLANTINGS
3. WHEN PLACED WITHIN THE CLEAR ZONE, GROUND COVER COULD BE DAMAGED WHEN HYDRANT IS OPERATED OR MAINTAINED.
4. WHERE ALLOWABLE WITHIN CITY OR COUNTY JURISDICTIONS, HYDRANTS MAY BE PLACED WITHIN THE SIDEWALK, IF THE SPACING REQUIREMENTS ARE MET AS SHOWN.

N:\Standards\2024\Details\DWG\503\_Fire Hydrant Clear Zone.dwg, 6/13/2024 10:49:59 AM



**TUALATIN VALLEY**  
WATER DISTRICT

APPROVED BY  
PETER BOONE

DRAWING SCALE  
NONE

FIRE HYDRANT  
CLEAR ZONE

EFF. DATE 07/01/24

STANDARD DETAIL

503

**GENERAL NOTES:**

1. THIS DETAIL SHALL BE USED IN CONJUNCTION WITH DETAILS 602, 603, 604, 605A, AND 605B.
2. DETAILS 601 THROUGH 605B APPLY ONLY TO WATER SERVICE CONNECTIONS 2" OR SMALLER. FOR CONNECTIONS LARGER THAN 2", REFER TO APPLICABLE STANDARDS AND DETAILS.
3. ONLY DISTRICT CREWS SHALL PERFORM WORK ON, OR MAKE MODIFICATIONS TO, THE ACTIVE WATER SYSTEM, UNLESS OTHERWISE APPROVED. DISTRICT SHALL INSTALL ALL METERS.
4. CONTRACTOR SHALL INSTALL SERVICE LINES, METER BOXES/VAULTS AND ASSOCIATED HARDWARE FOR NEW WATER IMPROVEMENTS.
5. CARE MUST BE TAKEN TO PROTECT INSTALLED WATER SERVICE LINES DURING SUBSEQUENT UTILITY INSTALLATIONS. ANY DISCOVERED DAMAGES WILL BE REPAIRED BY THE DISTRICT, AT THE DEVELOPER'S EXPENSE.

**MATERIAL NOTES:**

1. REFER TO PARTS LIST TABLE BELOW FOR ALLOWABLE PARTS WHEN CONSTRUCTING WATER SERVICE CONNECTIONS 2" OR SMALLER. REFER TO DETAIL 605B FOR ALLOWABLE METER BOXES AND LIDS.
2. COPPER TUBING SHALL BE TYPE K, SOFT, SEAMLESS, ANNEALED, CONFORMING TO ASTM B88. TUBING MUST BE AMERICAN OR CANADIAN MADE.

**CONSTRUCTION NOTES:**

1. CONTRACTOR SHALL PERFORM TAPS 2" OR SMALLER. TAPS LARGER THAN 2" SHALL BE PERFORMED BY DISTRICT-AUTHORIZED COMPANIES.
2. FOR CORPORATION STOP AND TAPPING SADDLE SPACING REQUIREMENTS, REFER TO DETAIL 602.
3. MINIMUM BENDING RADIUS FOR TYPE K SOFT COPPER IS 12". SERVICE LINES SHALL BE CONTINUOUS WITH NO CRIMPS OR KINKS. STRAIGHT COMPRESSION COUPLINGS MAY BE USED WITH PRIOR DISTRICT APPROVAL.
4. SERVICE LINES SHALL EXTEND PERPENDICULAR FROM THE MAINLINE TO THE ANGLE METER STOP OR U-BRANCH UNLESS OTHERWISE SHOWN.
5. LINE SIZE x 2" TEES (MJ x FIPT) SHALL BE USED FOR 1.5" AND 2" SERVICES ON NEW WATER IMPROVEMENTS. TAPPING SADDLES MAY ONLY BE USED WITH PRIOR DISTRICT APPROVAL.
6. COMPRESSION FITTINGS: CUT THE PIPE END STRAIGHT, CHAMFER AND CLEAN PRIOR TO INSERTING INTO THE FITTING. TIGHTEN THE COMPRESSION NUT UNTIL IT MAKES METAL-TO-METAL CONTACT WITH THE MACHINE SHOULDER OF THE STOP OR FITTING.

PARTS LIST TABLE (CATEGORIZED BY SERVICE LINE SIZE AND PART TYPE)

	1"	1" WITH U-BRANCH	1-1/2"	2"
CORPORATION STOP	FORD FB1000-4-Q-NL (CC x COMP) MUELLER N-25008N (CC x COMP)	FORD FB1000-4-Q-NL (CC x COMP) MUELLER N-25008N (CC x COMP)	-	-
TAPPING SADDLE	ROMAC 202NS <sup>1</sup> SMITH-BLAIR 317 <sup>1</sup> (MAINLINE SIZE x 1" FIPT)		ROMAC 202NS SMITH-BLAIR 317 (MAINLINE SIZE x 2" FIPT)	
ANGLE METER STOP (AMS)	MUELLER B-24258N (COMP x METER SWIVEL) FORD BA43-444W-Q-NL (COMP x METER SWIVEL)	MUELLER B-24265N (FIPT x SWIVEL NUT)	-	-
METER SETTER	-	-	FORD VBB76-86-12B-11-66-NL AY MCDONALD 739R612WWFF 665 MUELLER B-2429N 12" RISER	FORD VBB77-87-15B-11-77-NL MUELLER B-2429N 15" RISER
U-BRANCH	-	AY MCDONALD 708UQM 1" x 1" x 18" (COMP x MIPT)	-	-
COMP FITTINGS <sup>2</sup> (STRAIGHT)	MUELLER H-15403N FORD C44-44-Q-NL	MUELLER H-15403N FORD C44-44-Q-NL	MUELLER H-15403N FORD C44-66-Q-NL	MUELLER H-15403N FORD C44-77-Q-NL
COMP FITTINGS (QUARTER BEND)	-	-	MUELLER H-15526N FORD L44-66-Q-NL	MUELLER H-15526N FORD L44-77-Q-NL

<sup>1</sup> REQUIRED WHEN TAPPING 4" MAINLINE. USE FORD FB1100-4-Q-NL (MIPT X COMP) CORPORATION STOP.

<sup>2</sup> COPPER TUBING SHALL BE INSTALLED WITHOUT STRAIGHT COUPLERS, UNLESS OTHERWISE APPROVED BY DISTRICT.



**TUALATIN VALLEY  
WATER DISTRICT**

APPROVED BY  
PETER BOONE

DRAWING SCALE  
NONE

WATER SERVICE CONNECTION:  
GENERAL NOTES

EFF. DATE 07/01/24

STANDARD DETAIL

601

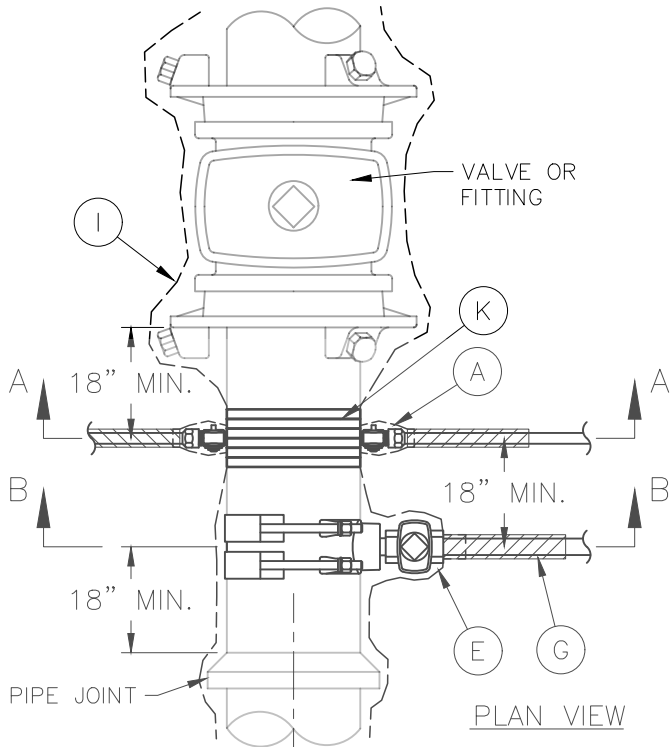

**GENERAL NOTES:**

1. REFER TO DETAIL 601 FOR WATER SERVICE CONNECTION NOTES AND PARTS LIST.
2. NO HIGH POINTS IN SERVICE LINE BETWEEN MAINLINE AND METER.

**KEYNOTES:**

- A. 1" CORPORATION STOP, CC x COMP
- B. 1" TYPE K SOFT COPPER TUBING
- C. 2" DOUBLE STRAP TAPPING SADDLE, OR LINE-SIZE X 2" TEE (MJ x FIPT); TAPPING SADDLE SHOW.
- D. 2" MIPT BRASS NIPPLE
- E. 2" IRON BODY GATE VALVE, FIPT x FIPT
- F. 2" MIPT x LINE-SIZE COMP ADAPTER
- G. WRAP COPPER SERVICE LINE, HALF-LAPPED, WITH 10-MIL PVC ADHESIVE TAPE, FOR A MIN. OF 3' FROM MAIN. WRAP CORPORATION STOP WITH POLYETHYLENE ENCASUREMENT AND SECURE WITH TAPE.
- H. 1.5" OR 2" TYPE K SOFT COPPER TUBING. ROLLED COPPER NOT PERMITTED.
- I. POLYETHYLENE ENCASUREMENT. SEE DETAIL 301.
- J. VALVE SETTING PER STANDARD DETAIL 402.
- K. PRIOR TO TAP, WRAP MAIN WITH THREE LAYERS, 10-MIL PVC ADHESIVE TAPE. PROVIDE ADEQUATE COVERAGE FOR TAPPING MACHINE. REFER TO DISTRICT STANDARDS SECTION 3.3.L FOR TAPPING POLYETHYLENE ENCASED MAINLINE.
- L. LINE-SIZE COPPER COMPRESSION OR SWEAT BEND.

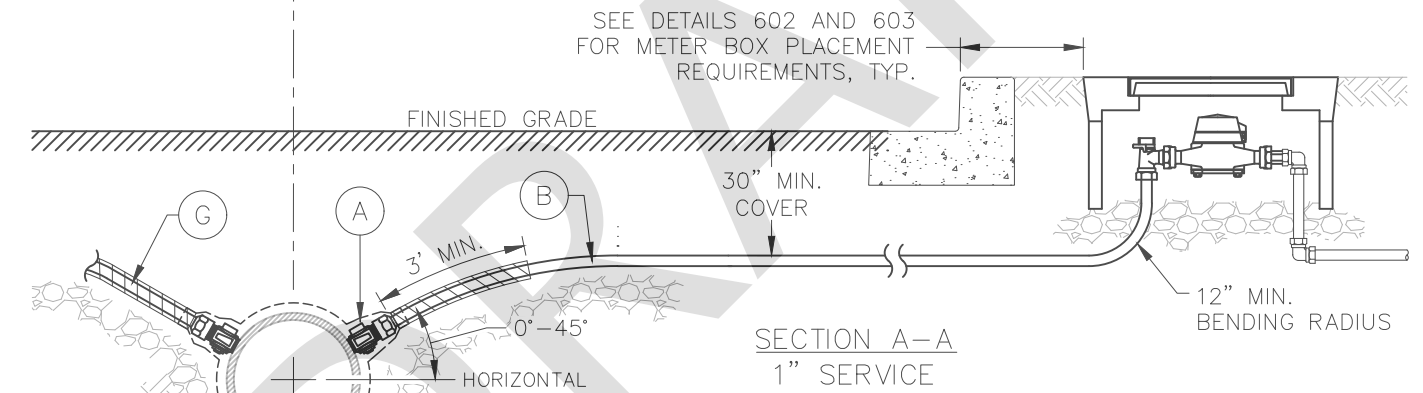

SECTION A-A  
1" SERVICE

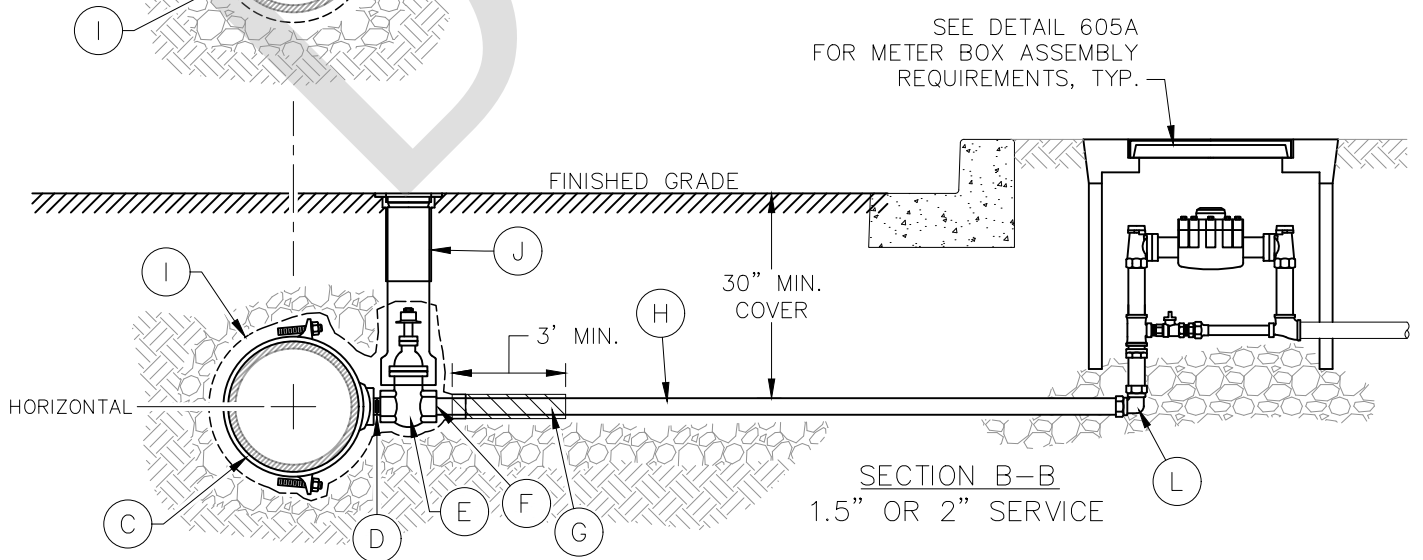

SECTION B-B  
1.5" OR 2" SERVICE

N:\Standards\2024\Details\DWG\602\_Water Service Connection\_Service Installation.dwg, 6/13/2024 10:51:44 AM

**TUALATIN VALLEY**  
WATER DISTRICT

APPROVED BY  
PETER BOONE

DRAWING SCALE  
NONE

WATER SERVICE CONNECTION:  
SERVICE INSTALLATION

EFF. DATE 07/01/24

STANDARD DETAIL  
**602**

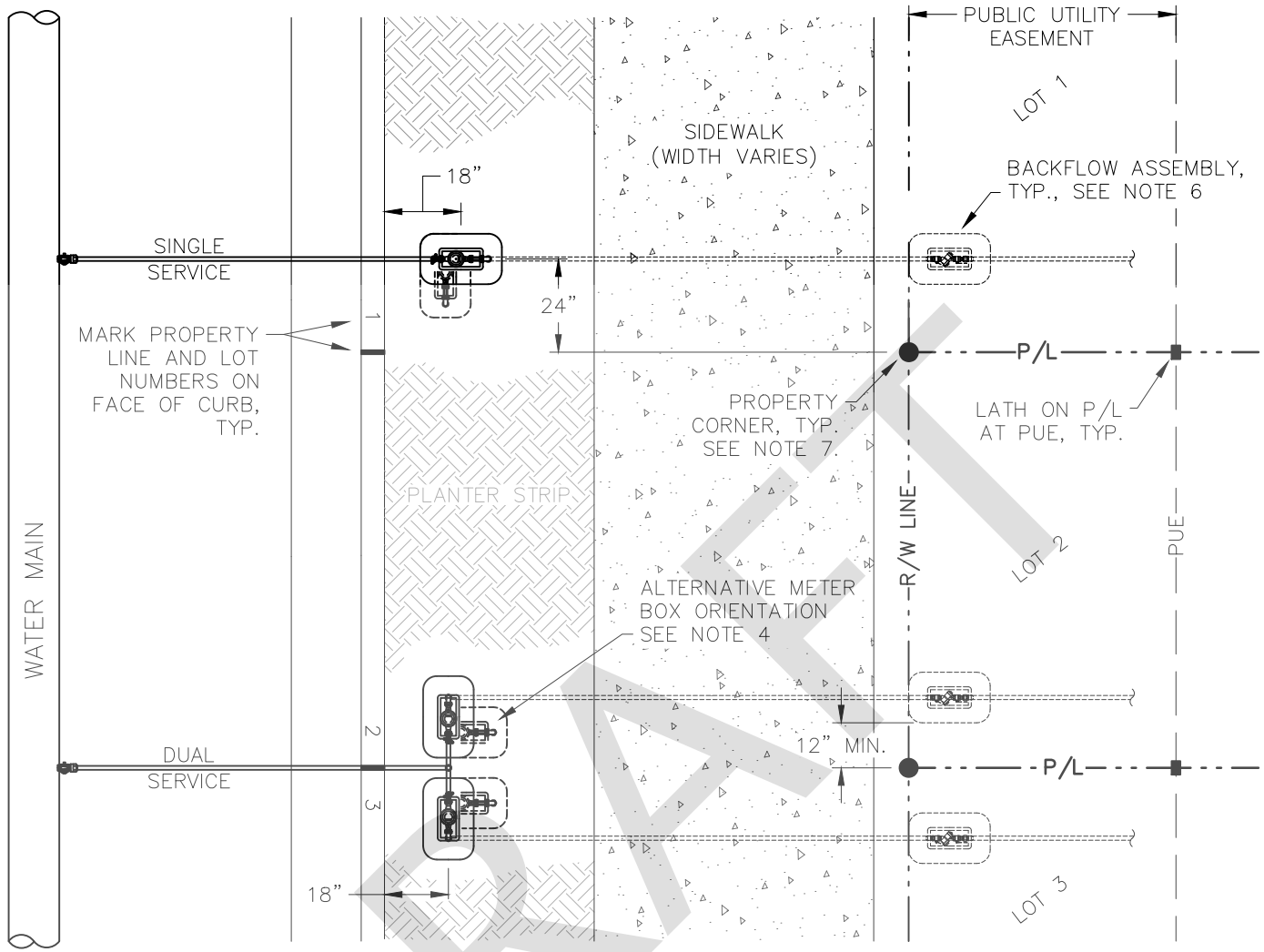

**NOTES:**

1. THIS DETAIL SHALL BE USED IN CONJUNCTION WITH 601, 602, 605A, AND 605B.
2. THIS DETAIL APPLIES ONLY TO WATER SERVICE CONNECTIONS 2" OR SMALLER.
3. NEW SERVICE LINES SHALL BE A MINIMUM 1" DIAMETER UNLESS OTHERWISE NOTED ON THE APPROVED PLANS.
4. LOCATION AND ORIENTATION OF METER BOXES SHALL BE APPROVED BY DISTRICT INSPECTOR PRIOR TO INSTALLATION.
5. DEVELOPER'S SURVEYOR SHALL:
  - 5.1. SET A LATH AT THE INTERSECTION OF THE PROPERTY LINE AND THE PUBLIC UTILITY EASEMENT.
  - 5.2. SET A LATH AT THE INTERSECTION OF THE PROPERTY CORNER AND THE RIGHT-OF-WAY LINE, IF MONUMENT HAS NOT YET BEEN SET AT THE TIME OF SERVICE INSTALLATION.
  - 5.3. MARK PROPERTY LINE AND LOT NUMBERS ON FACE OF CURB WITH WHITE PAINT.
  - 5.4. MARK METER BOX LOCATION(S) AND SET GRADE HUBS, IF CURBS ARE NOT INSTALLED AT THE TIME OF SERVICE INSTALLATION.
6. SEE SECTION 8.2. OF THE STANDARDS FOR BACKFLOW REQUIREMENTS.
7. ORS 92.044(7) PROHIBITS LOCATING ANY UTILITY INFRASTRUCTURE WITHIN 1-FT OF A SURVEY MONUMENT. DEVELOPER SHALL PAY FOR ANY RELOCATION OF SERVICES AND/OR METER BOXES FOUND TO FALL WITHIN 1-FT OF A SURVEY MONUMENT LOCATION.



**TUALATIN VALLEY**  
WATER DISTRICT

APPROVED BY  
PETER BOONE

DRAWING SCALE  
NONE

WATER SERVICE CONNECTION:  
METER BOX PLACEMENT  
IN PLANTER STRIP

EFF. DATE 07/01/24

STANDARD DETAIL

603

N:\Standards\2024\Details\DWG\604\_Water Service Connection, Meter Box Placement behind Sidewalk.dwg, 6/13/2024 10:51:07 AM

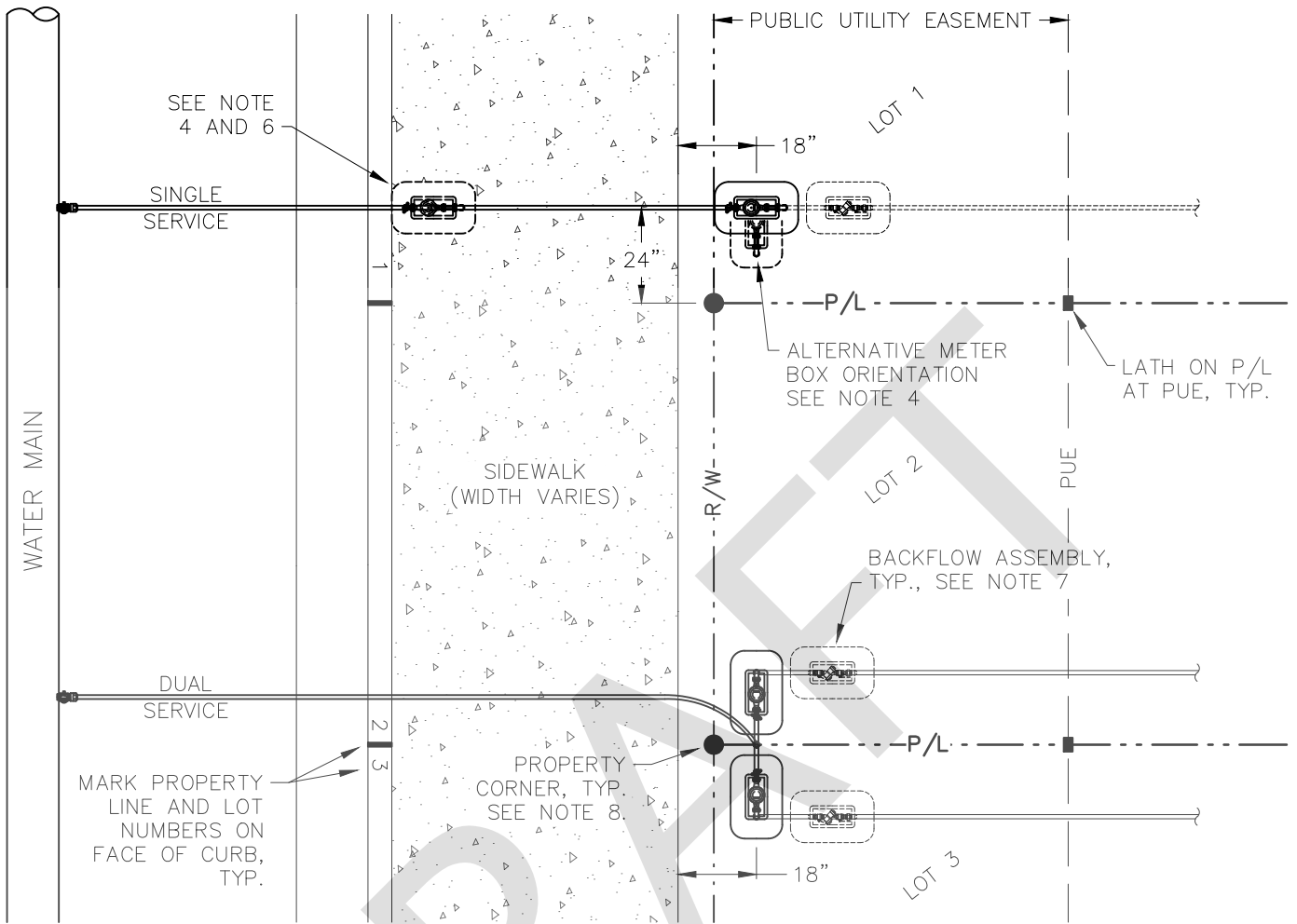

**NOTES:**

1. THIS DETAIL SHALL BE USED IN CONJUNCTION WITH 601, 602, AND 605.
2. THIS DETAIL APPLIES ONLY TO WATER SERVICE CONNECTIONS 2" OR SMALLER.
3. NEW SERVICE LINES SHALL BE A MINIMUM 1" DIAMETER UNLESS OTHERWISE NOTED ON THE APPROVED PLANS.
4. LOCATION AND ORIENTATION OF METER BOXES SHALL BE APPROVED BY DISTRICT INSPECTOR PRIOR TO INSTALLATION.
5. DEVELOPER'S SURVEYOR SHALL:
  - 5.1. SET A LATH AT THE INTERSECTION OF THE PROPERTY LINE AND THE PUBLIC UTILITY EASEMENT.
  - 5.2. SET A LATH AT THE INTERSECTION OF THE PROPERTY CORNER AND THE RIGHT-OF-WAY LINE, IF MONUMENT HAS NOT YET BEEN SET AT THE TIME OF SERVICE INSTALLATION.
  - 5.3. MARK PROPERTY LINE AND LOT NUMBERS ON FACE OF CURB WITH WHITE PAINT.
  - 5.4. MARK METER BOX LOCATION(S) AND SET GRADE HUBS, IF CURBS ARE NOT INSTALLED AT THE TIME OF SERVICE INSTALLATION.
6. SHOWN IN SIDEWALK FOR INFORMATION ONLY. SINGLE SERVICE WATER METERS SHALL ONLY BE INSTALLED IN SIDEWALK IF APPROVED BY DISTRICT ENGINEER. DUAL SERVICE WATER METERS ARE NOT PERMITTED WITHIN SIDEWALKS. METER BOXES SHALL BE INSPECTED BY DISTRICT PRIOR TO POURING CONCRETE SIDEWALK.
7. SEE SECTION 8.2. OF THE STANDARDS FOR BACKFLOW REQUIREMENTS.
8. ORS 92.044(7) PROHIBITS LOCATING ANY UTILITY INFRASTRUCTURE WITHIN 1-FT OF A SURVEY MONUMENT. DEVELOPER SHALL PAY FOR ANY RELOCATION OF SERVICES AND/OR METER BOXES FOUND TO FALL WITHIN 1-FT OF A SURVEY MONUMENT LOCATION.



**TUALATIN VALLEY**  
WATER DISTRICT

APPROVED BY  
PETER BOONE

DRAWING SCALE  
NONE

WATER SERVICE CONNECTION:  
METER BOX PLACEMENT  
BEHIND SIDEWALK

EFF. DATE 07/01/24

STANDARD DETAIL

604

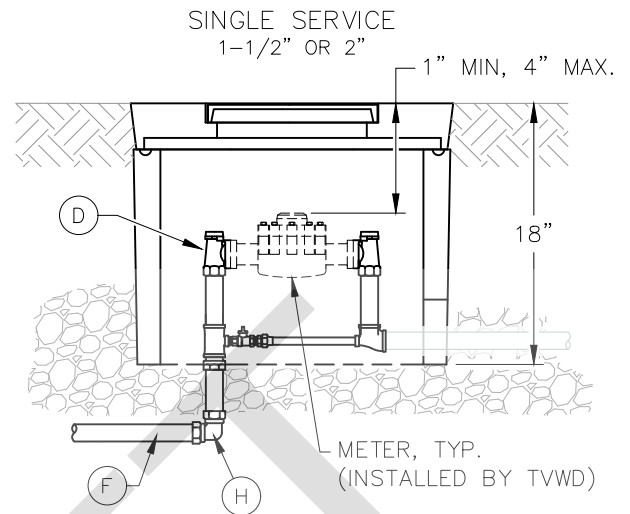
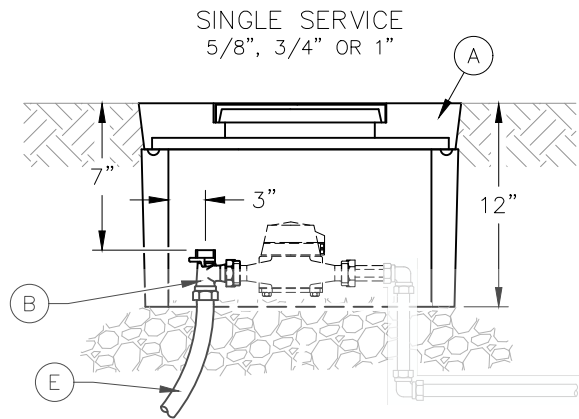

DUAL (U-BRANCH) SERVICE  
5/8", 3/4", OR 1"

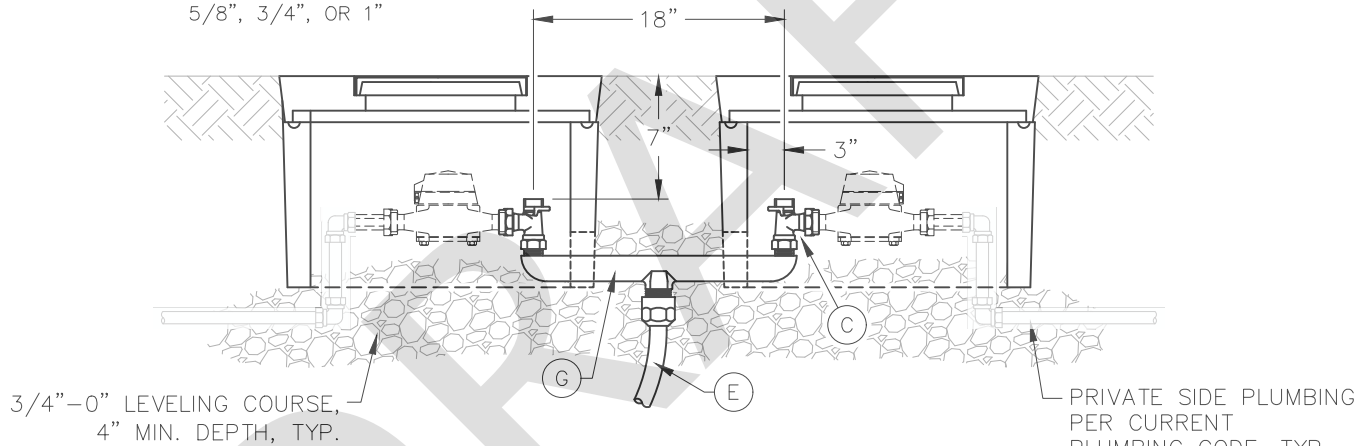

**GENERAL NOTES:**

1. REFER TO DETAIL 605B FOR ALLOWABLE METER BOX MANUFACTURERS.
2. THIS DETAIL SHALL BE USED IN CONJUNCTION WITH DETAILS 601 THROUGH 605B. REFER TO DETAIL 601 FOR ALLOWABLE HARDWARE.
3. DISTRICT SHALL INSTALL ALL METERS AFTER PROJECT ACCEPTANCE AND APPLICABLE FEES ARE PAID.
4. METER BOXES SHALL BE SET PLUMB, WITH THE TOP SET HORIZONTALLY.
5. COMMERCIAL PROPERTIES SERVED BY A 1" METER MUST BE SERVED BY A SINGLE SERVICE.

**KEYNOTES:**

- A. METER BOX, TYP.
- B. SINGLE SERVICE ANGLE METER STOP, COMP x METER SWIVEL
- C. DUAL SERVICE ANGLE METER STOP, FIPT x METER SWIVEL
- D. 1.5" OR 2" METER RESETTER
- E. 1" TYPE K SOFT COPPER TUBING. 12" MIN. BENDING RADIUS.
- F. 1.5" OR 2" TYPE K SOFT COPPER TUBING.
- G. U-BRANCH, 1" COMP x 1" MIPT.
- H. COPPER COMPRESSION OR SWEAT 90° BEND.



**TUALATIN VALLEY  
WATER DISTRICT**

APPROVED BY  
PETER BOONE

DRAWING SCALE  
NONE

WATER SERVICE CONNECTION:  
METER BOX ASSEMBLY

EFF. DATE 07/01/24

STANDARD DETAIL

605A

**GENERAL NOTES:**

1. THIS DETAIL SHALL BE USED IN CONJUNCTION WITH DETAILS 601 THROUGH 605A.
2. IT SHALL BE THE RESPONSIBILITY OF THE CONTRACTOR TO INSTALL THE CORRECT METER BOX AND COVER FOR THE CORRESPONDING USE TYPE. INCORRECTLY INSTALLED METER BOXES OR COVERS SHALL BE AT CONTRACTOR'S EXPENSE.
3. METER BOXES AND COVERS WITHIN A SUBDIVISION SHALL BE OF THE SAME MANUFACTURER.
4. STANDARD USE TYPE IS METER BOXES LOCATED WITHIN PLANTER STRIPS OR BEHIND SIDEWALKS, OUTSIDE OF HARD SURFACES.
5. TRAFFIC-RATED METER BOXES AND COVERS ARE REQUIRED WHEN LOCATED IN DRIVEWAYS, DRIVEWAY APPROACH APRONS, SIDEWALKS, OR OTHER AREAS AS DETERMINED BY THE DISTRICT ENGINEER.
6. PEDESTRIAN HARD SURFACE USE TYPE IS A PEDESTRIAN ACCESS ROUTE AS DEFINED BY PROWAG SECTION R302. EXAMPLES INCLUDE SIDEWALKS, CURB RAMP AREAS, OR OTHER TRAVELED PEDESTRIAN AREAS.
7. NON-PEDESTRIAN HARD SURFACE USE TYPE IS A NON-DRIVABLE, HARD SURFACE WHERE NO PEDESTRIAN TRAFFIC IS ANTICIPATED. EXAMPLES INCLUDE FURNITURE ZONES OR ELEVATED CONCRETE AREAS.

METER BOX AND COVER TABLE (CATEGORIZED BY METER SIZE AND USE TYPE)

METER SIZE	STANDARD	TRAFFIC <sup>1</sup> RATED	PEDESTRIAN HARD SURFACE <sup>2</sup>	NON-PEDESTRIAN HARD SURFACE
1" OR SMALLER	ARMORCAST A6000485 (BOX) A6000484RCI (LID)  BROOKS #37 (BOX) WITH READER LID	ARMORCAST A6001946PCX12 (BOX) A6001969TRCI (LID)	ARMORCAST A6001946PCX12 (BOX) A6001969T (LID)  BROOKS #38 (BOX) WITH SOLID LID  SIGMA RAVEN N1324BLKWAT	ARMORCAST A6001946PCX12 (BOX) A6001969TRCI (LID)  BROOKS #38 (BOX) WITH READER LID  DFW PLASTICS DFW1324C4-12-4CA  SIGMA RAVEN N1324BLKWAT-RTO
1-1/2" AND 2"	ARMORCAST A6001640PCX18 (BOX) A6001643RCI (LID)  BROOKS #66 (BOX) WITH READER LID  DFW PLASTICS DFW1324C-4CT<>-LID  SIGMA RAVEN N1730BLKWAT	ARMORCAST A6001640PCX18 (BOX) A6001947TRCI (LID)	ARMORCAST A6001640PCX18 (BOX) A6001947T (LID)  BROOKS #66 (BOX) WITH SOLID LID  DFW PLASTICS DFW1730C4-12-4M-NHK  SIGMA RAVEN N1730BLKWAT	ARMORCAST A6001640PCX18 (BOX) A6001947TRCI (LID)  BROOKS #66 (BOX) WITH READER LID

<sup>1</sup> TRAFFIC-RATED METER BOXES AND COVERS MUST MEET AASHTO H-20 LOADING DESIGN CRITERIA.

<sup>2</sup> PEDESTRIAN HARD SURFACE METER BOXES AND COVERS MUST MEET ALL ADA AND PROWAG REQUIREMENTS FOR LIPS AND GAPS.

N:\Standards\2024\Details\DWG\605B\_Water Service Connection, Approved Meter Boxes and Covers.dwg, 6/13/2024 10:52:35 AM



**TUALATIN VALLEY  
WATER DISTRICT**

APPROVED BY  
PETER BOONE

DRAWING SCALE  
NONE

WATER SERVICE CONNECTION:  
APPROVED METER BOXES  
AND COVERS

EFF. DATE 07/01/24

STANDARD DETAIL  
**605B**



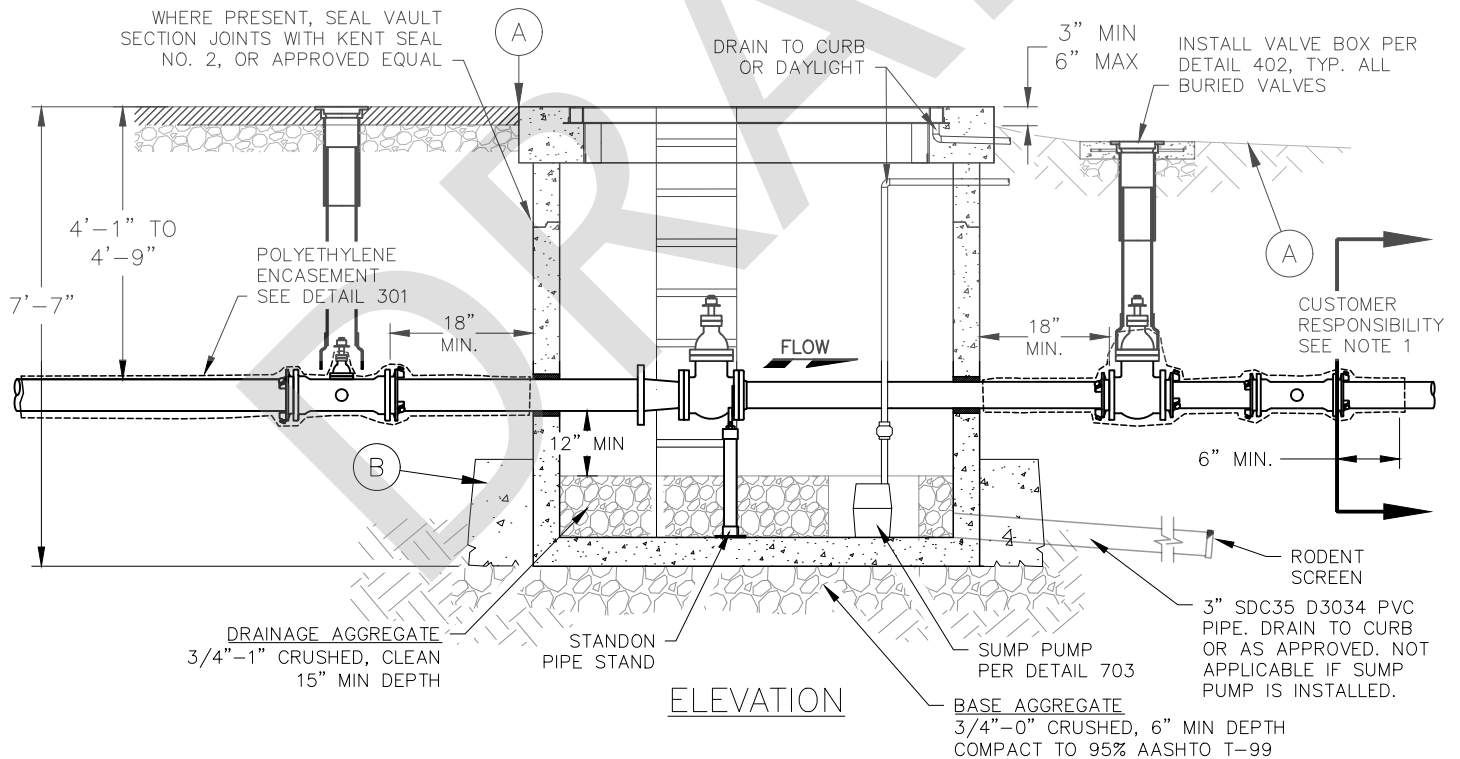
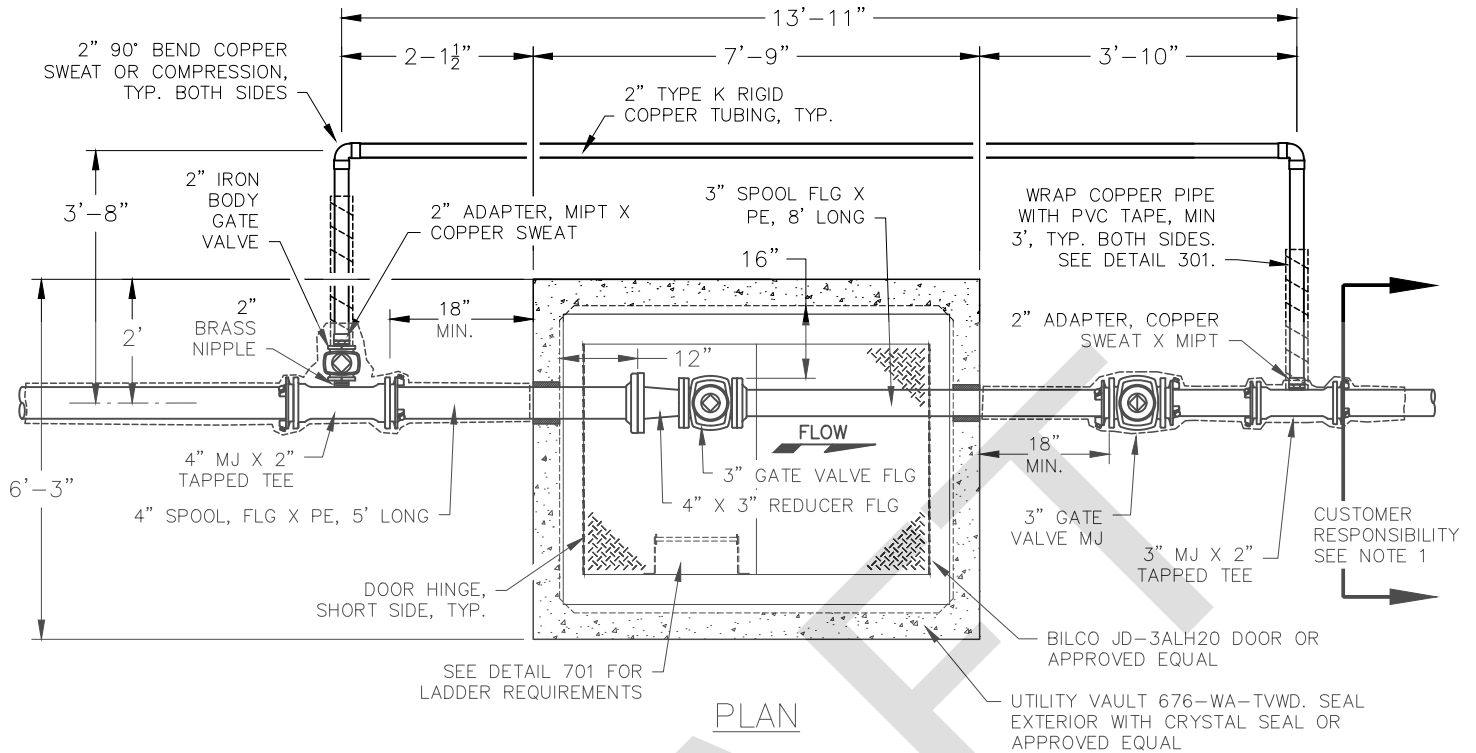

**NOTES:**

- CUSTOMER OWNERSHIP AND MAINTENANCE RESPONSIBILITY BEGINS DIRECTLY DOWNSTREAM OF 3" X 2" TEE.
- CONTRACTOR TO SEAL ALL OPENINGS IN VAULT WITH NON-SHRINK GROUT.
- ORS 92.044(7) PROHIBITS LOCATING ANY UTILITY INFRASTRUCTURE WITHIN 1-FT. OF A SURVEY MONUMENT. DEVELOPER SHALL PAY FOR ANY RELOCATION OF SERVICES AND/OR METER BOXES FOUND TO FALL WITHIN 1-FT. OF A SURVEY MONUMENT LOCATION.

**KEYNOTES:**

- IN LANDSCAPED AREAS, GRADE SHALL SLOPE AWAY FROM VAULT. IN PAVED AREAS, GRADE SHALL BE FLUSH WITH TOP OF VAULT LID.
- CONTRACTOR TO INSTALL 3 CU YD MIN CONCRETE BALLAST AROUND BASE OF VAULT IN AREAS WHERE FLOODING OR HIGH GROUND WATER EXISTS.



**TUALATIN VALLEY  
WATER DISTRICT**

APPROVED BY  
PETER BOONE

DRAWING SCALE  
NONE

3" METER INSTALLATION

EFF. DATE 07/01/24

STANDARD DETAIL

606

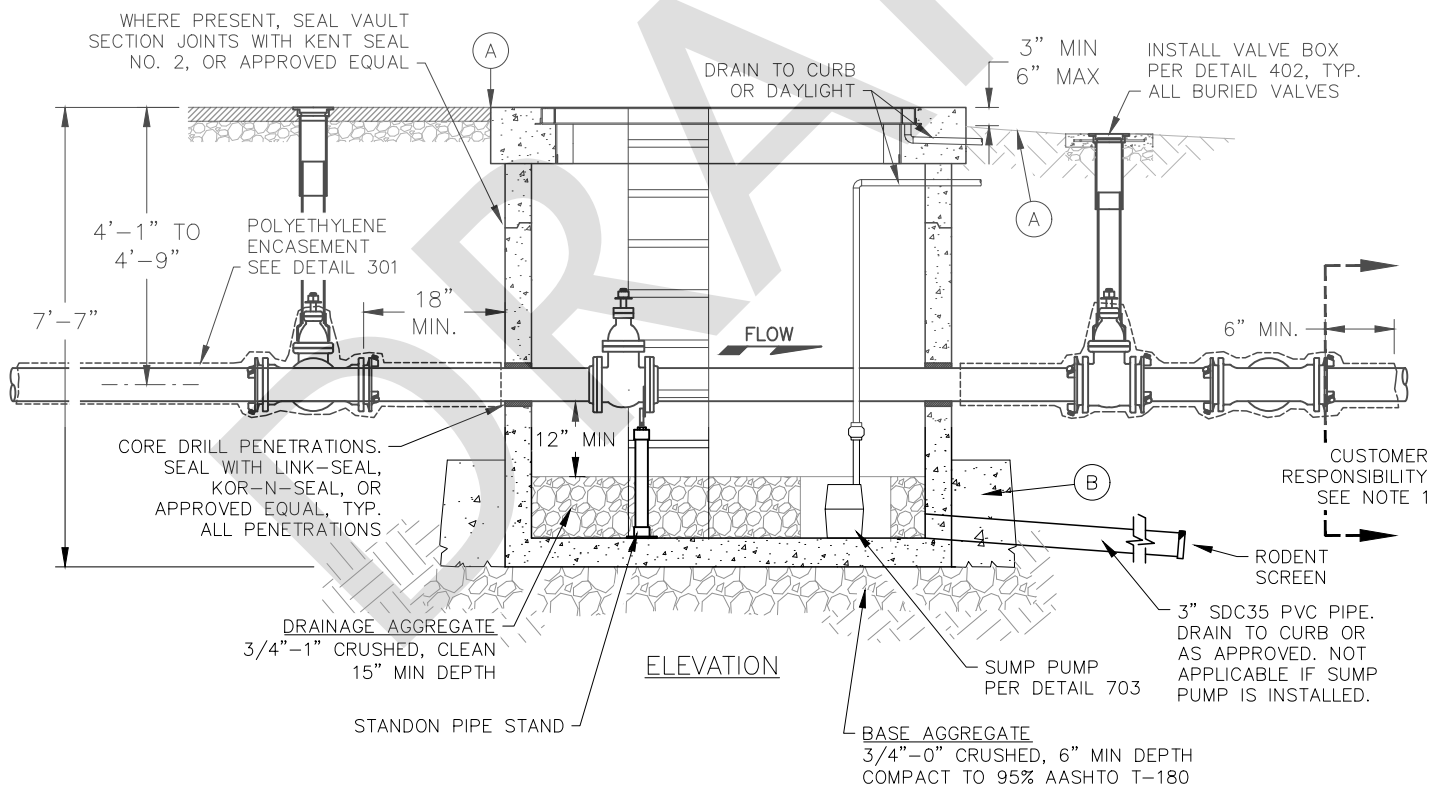
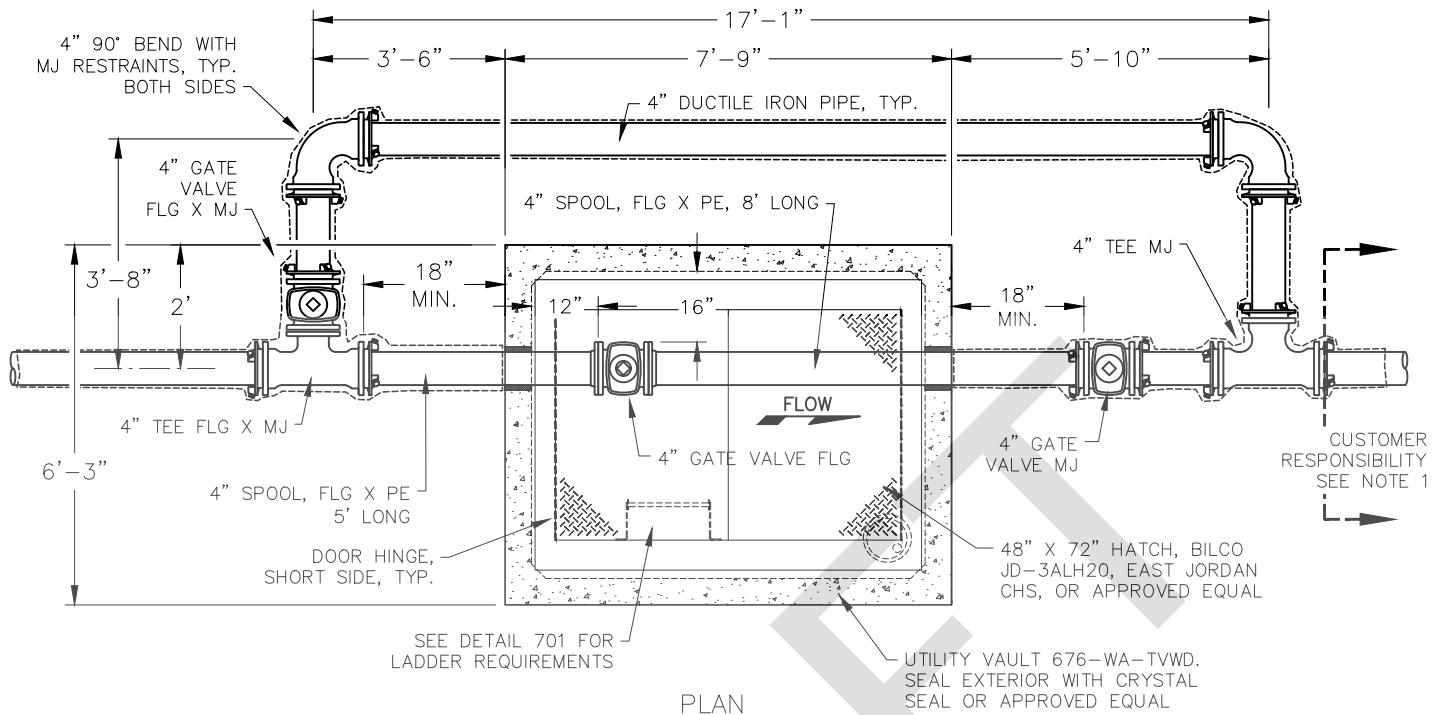

**NOTES:**

1. CUSTOMER OWNERSHIP AND MAINTENANCE RESPONSIBILITY BEGINS DIRECTLY DOWNSTREAM OF 4" TEE.
2. CONTRACTOR TO SEAL ALL OPENINGS IN VAULT WITH NON-SHRINK GROUT.
3. ORS 92.044(7) PROHIBITS LOCATING ANY UTILITY INFRASTRUCTURE WITHIN 1-FT. OF A SURVEY MONUMENT. DEVELOPER SHALL PAY FOR ANY RELOCATION OF SERVICES AND/OR METER BOXES FOUND TO FALL WITHIN 1-FT. OF A SURVEY MONUMENT LOCATION.

**KEYNOTES:**

- A. IN LANDSCAPED AREAS, GRADE SHALL SLOPE AWAY FROM VAULT. IN PAVED AREAS, GRADE SHALL BE FLUSH WITH TOP OF VAULT LID.
- B. CONTRACTOR TO INSTALL 3 CU YD MIN CONCRETE BALLAST AROUND BASE OF VAULT IN AREAS WHERE FLOODING OR HIGH GROUND WATER EXISTS.



**TUALATIN VALLEY  
WATER DISTRICT**

APPROVED BY  
PETER BOONE

DRAWING SCALE  
NONE

4" METER INSTALLATION

EFF. DATE 07/01/24

STANDARD DETAIL

607

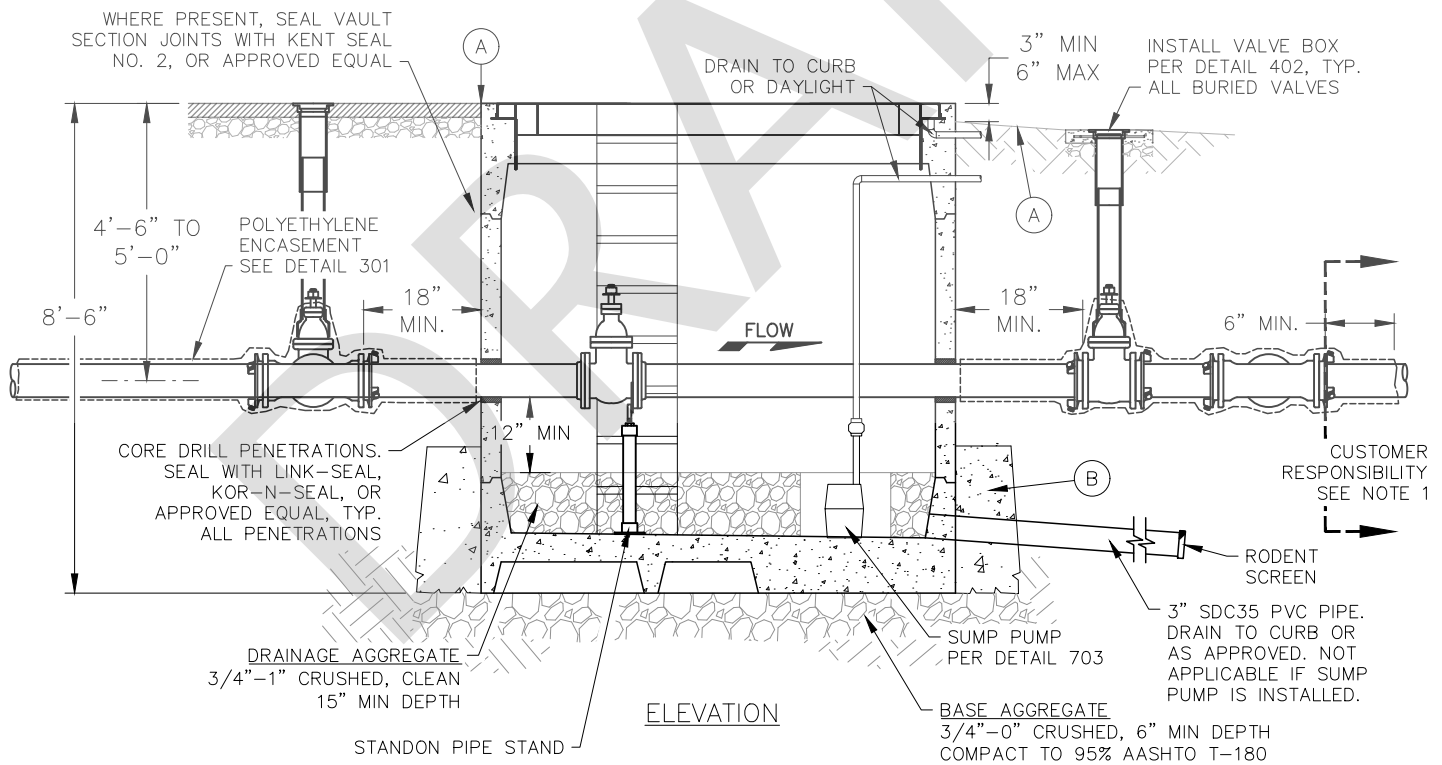
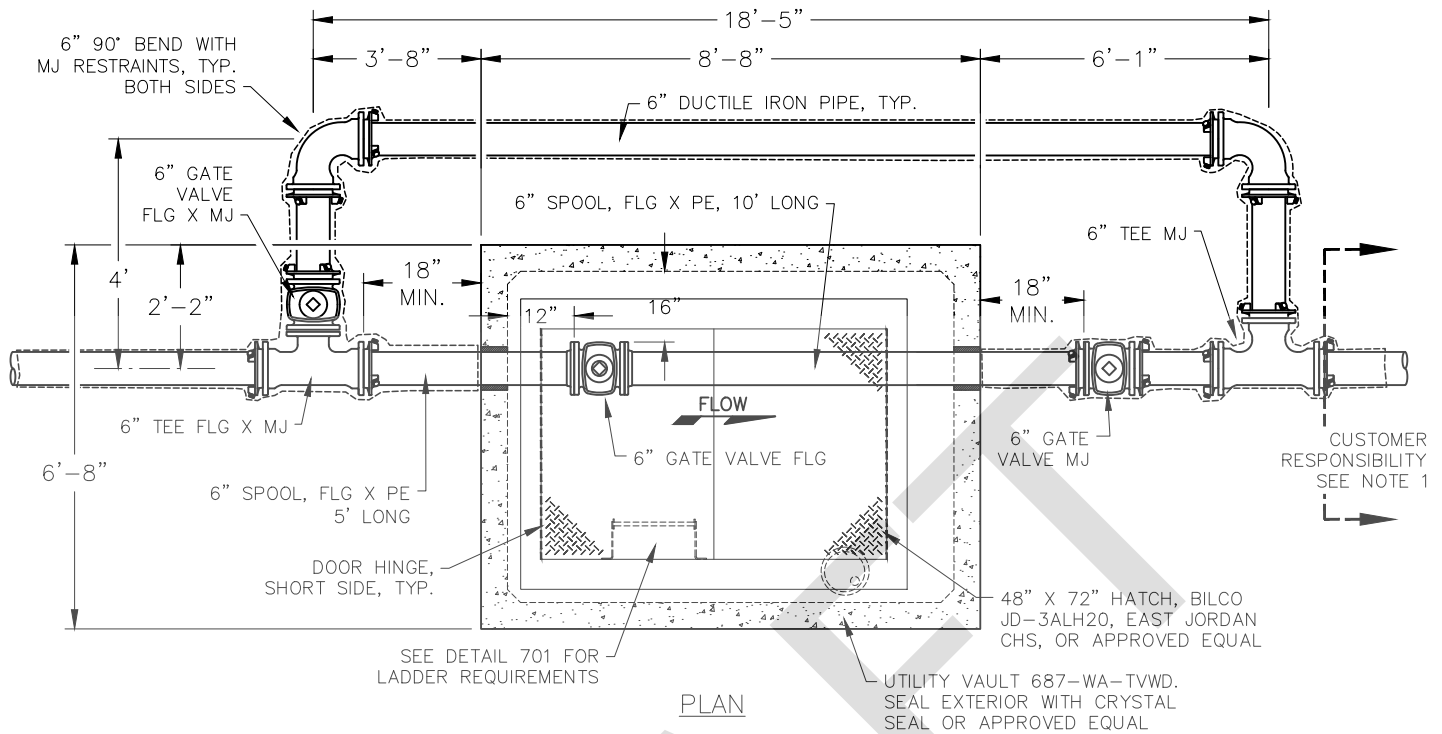

**NOTES:**

1. CUSTOMER OWNERSHIP AND MAINTENANCE RESPONSIBILITY BEGINS DIRECTLY DOWNSTREAM OF 6" TEE.
2. CONTRACTOR TO SEAL ALL OPENINGS IN VAULT WITH NON-SHRINK GROUT.
3. ORS 92.044(7) PROHIBITS LOCATING ANY UTILITY INFRASTRUCTURE WITHIN 1-FT. OF A SURVEY MONUMENT. DEVELOPER SHALL PAY FOR ANY RELOCATION OF SERVICES AND/OR METER BOXES FOUND TO FALL WITHIN 1-FT. OF A SURVEY MONUMENT LOCATION.

**KEYNOTES:**

- A. IN LANDSCAPED AREAS, GRADE SHALL SLOPE AWAY FROM VAULT. IN PAVED AREAS, GRADE SHALL BE FLUSH WITH TOP OF VAULT LID.
- B. CONTRACTOR TO INSTALL 3 CU YD MIN CONCRETE BALLAST AROUND BASE OF VAULT IN AREAS WHERE FLOODING OR HIGH GROUND WATER EXISTS.



**TUALATIN VALLEY  
WATER DISTRICT**

APPROVED BY  
PETER BOONE

DRAWING SCALE  
NONE

6" METER INSTALLATION

EFF. DATE 07/01/24

STANDARD DETAIL

608

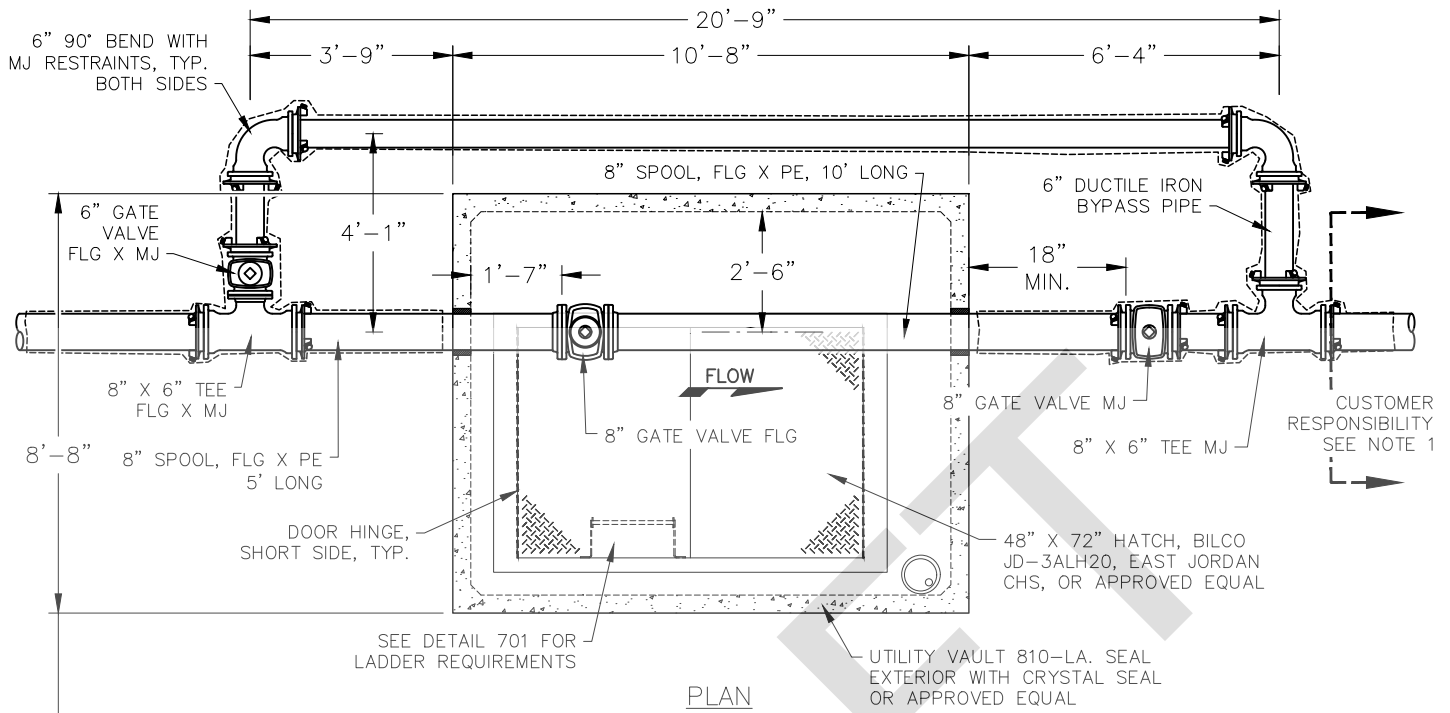

PLAN

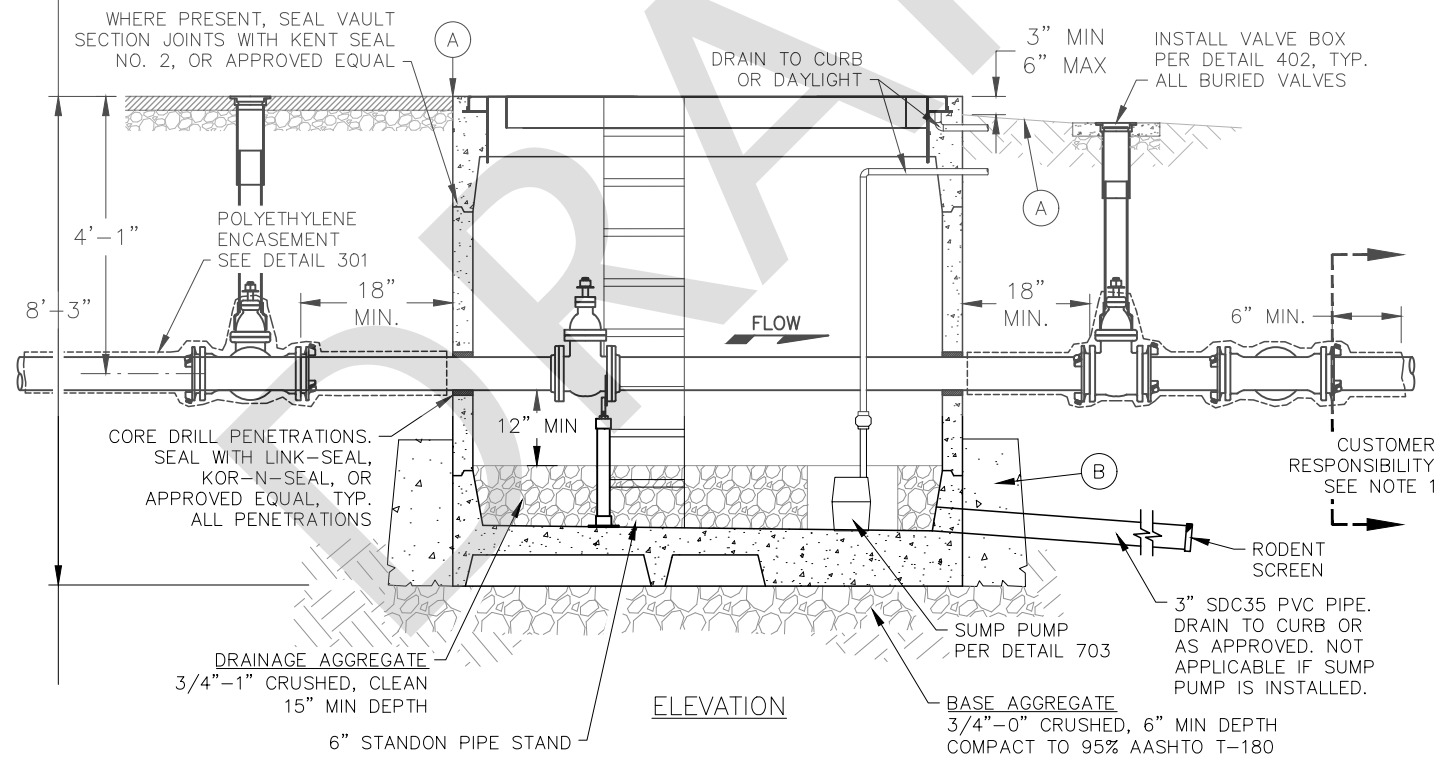

ELEVATION

**NOTES:**

1. CUSTOMER OWNERSHIP AND MAINTENANCE RESPONSIBILITY BEGINS DIRECTLY DOWNSTREAM OF 8" X 6" TEE.
2. CONTRACTOR TO SEAL ALL OPENINGS IN VAULT WITH NON-SHRINK GROUT.
3. ORS 92.044(7) PROHIBITS LOCATING ANY UTILITY INFRASTRUCTURE WITHIN 1-FT. OF A SURVEY MONUMENT. DEVELOPER SHALL PAY FOR ANY RELOCATION OF SERVICES AND/OR METER BOXES FOUND TO FALL WITHIN 1-FT. OF A SURVEY MONUMENT LOCATION.

**KEYNOTES:**

- A. IN LANDSCAPED AREAS, GRADE SHALL SLOPE AWAY FROM VAULT. IN PAVED AREAS, GRADE SHALL BE FLUSH WITH TOP OF VAULT LID.
- B. CONTRACTOR TO INSTALL 3 CU YD MIN CONCRETE BALLAST AROUND BASE OF VAULT IN AREAS WHERE FLOODING OR HIGH GROUND WATER EXISTS.

N:\Standards\2024\Details\DWG\609\_8-inch Meter Installation.dwg, 6/13/2024 10:53:31 AM



**TUALATIN VALLEY**  
WATER DISTRICT

APPROVED BY  
PETER BOONE

DRAWING SCALE  
NONE

8" METER INSTALLATION

EFF. DATE 07/01/24

STANDARD DETAIL

609

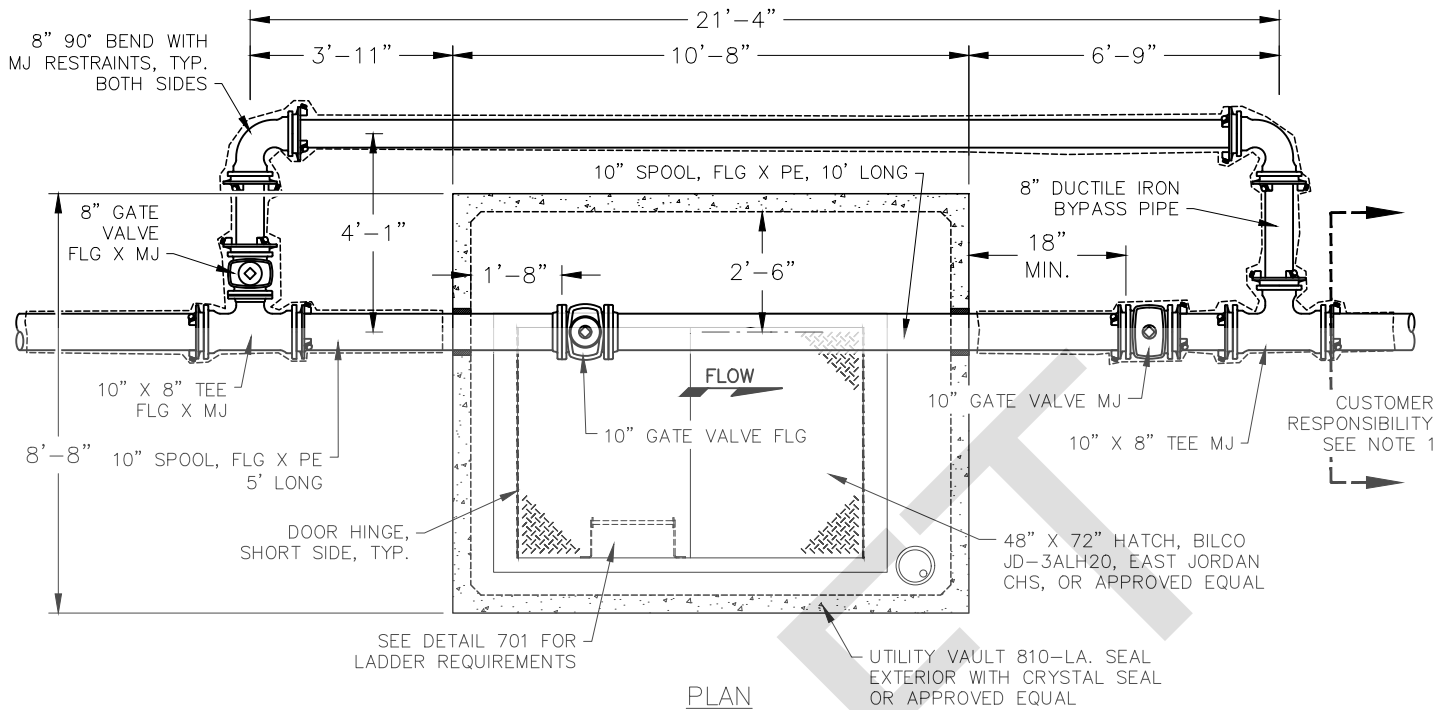

PLAN

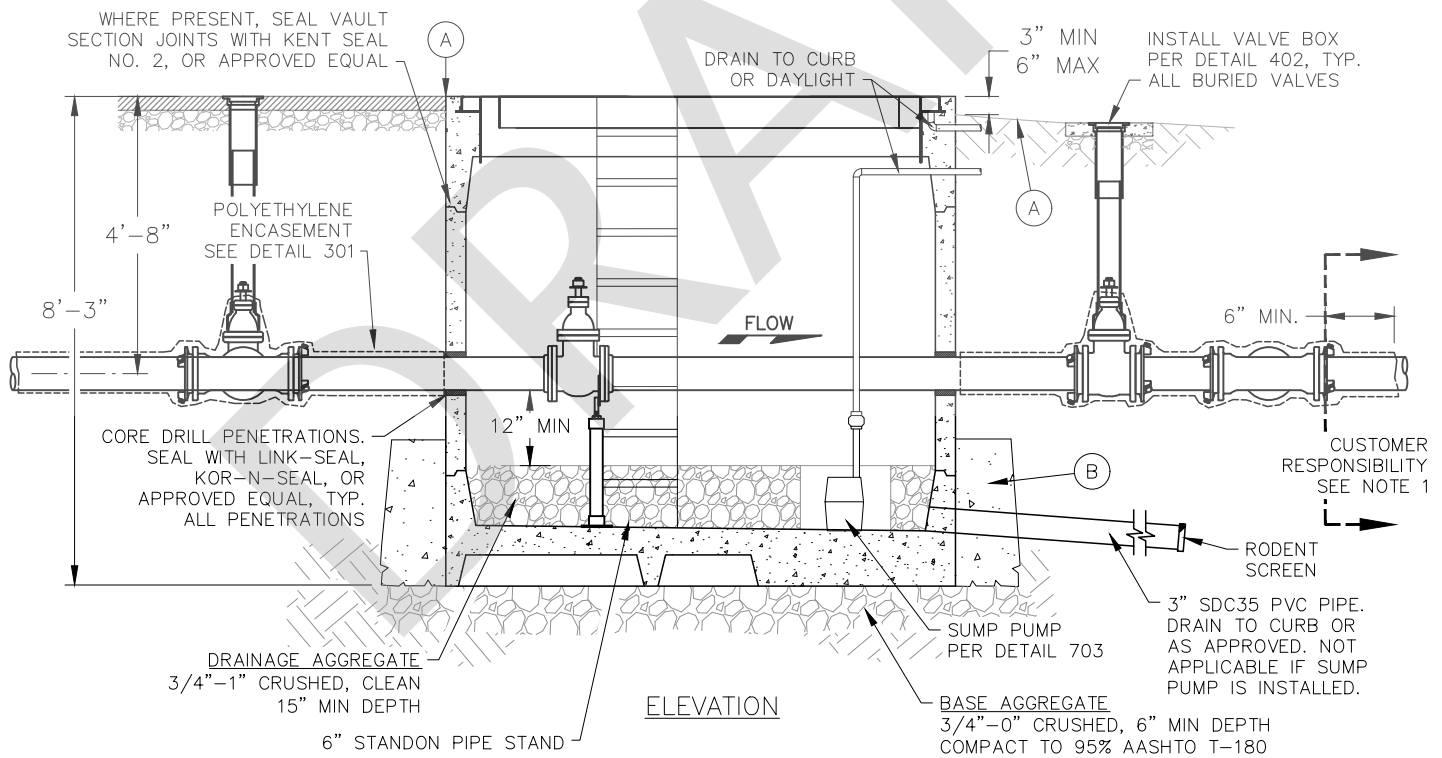

ELEVATION

**NOTES:**

1. CUSTOMER OWNERSHIP AND MAINTENANCE RESPONSIBILITY BEGINS DIRECTLY DOWNSTREAM OF 10" x 8" TEE.
2. CONTRACTOR TO SEAL ALL OPENINGS IN VAULT WITH NON-SHRINK GROUT.
3. ORS 92.044(7) PROHIBITS LOCATING ANY UTILITY INFRASTRUCTURE WITHIN 1-FEET OF A SURVEY MONUMENT. DEVELOPER SHALL PAY FOR ANY RELOCATION OF SERVICES AND/OR METER BOXES FOUND TO FALL WITHIN 1-FEET OF A SURVEY MONUMENT LOCATION.

**KEYNOTES:**

- A. IN LANDSCAPED AREAS, GRADE SHALL SLOPE AWAY FROM VAULT. IN PAVED AREAS, GRADE SHALL BE FLUSH WITH TOP OF VAULT LID.
- B. CONTRACTOR TO INSTALL 3 CU YD MIN CONCRETE BALLAST AROUND BASE OF VAULT IN AREAS WHERE FLOODING OR HIGH GROUND WATER EXISTS.

N:\Standards\2024\Details\DWG\610\_10-inch Meter Installation.dwg, 6/13/2024 10:53:45 AM



**TUALATIN VALLEY  
WATER DISTRICT**

APPROVED BY  
PETER BOONE

DRAWING SCALE  
NONE

10" METER INSTALLATION

EFF. DATE 07/01/24

STANDARD DETAIL

610

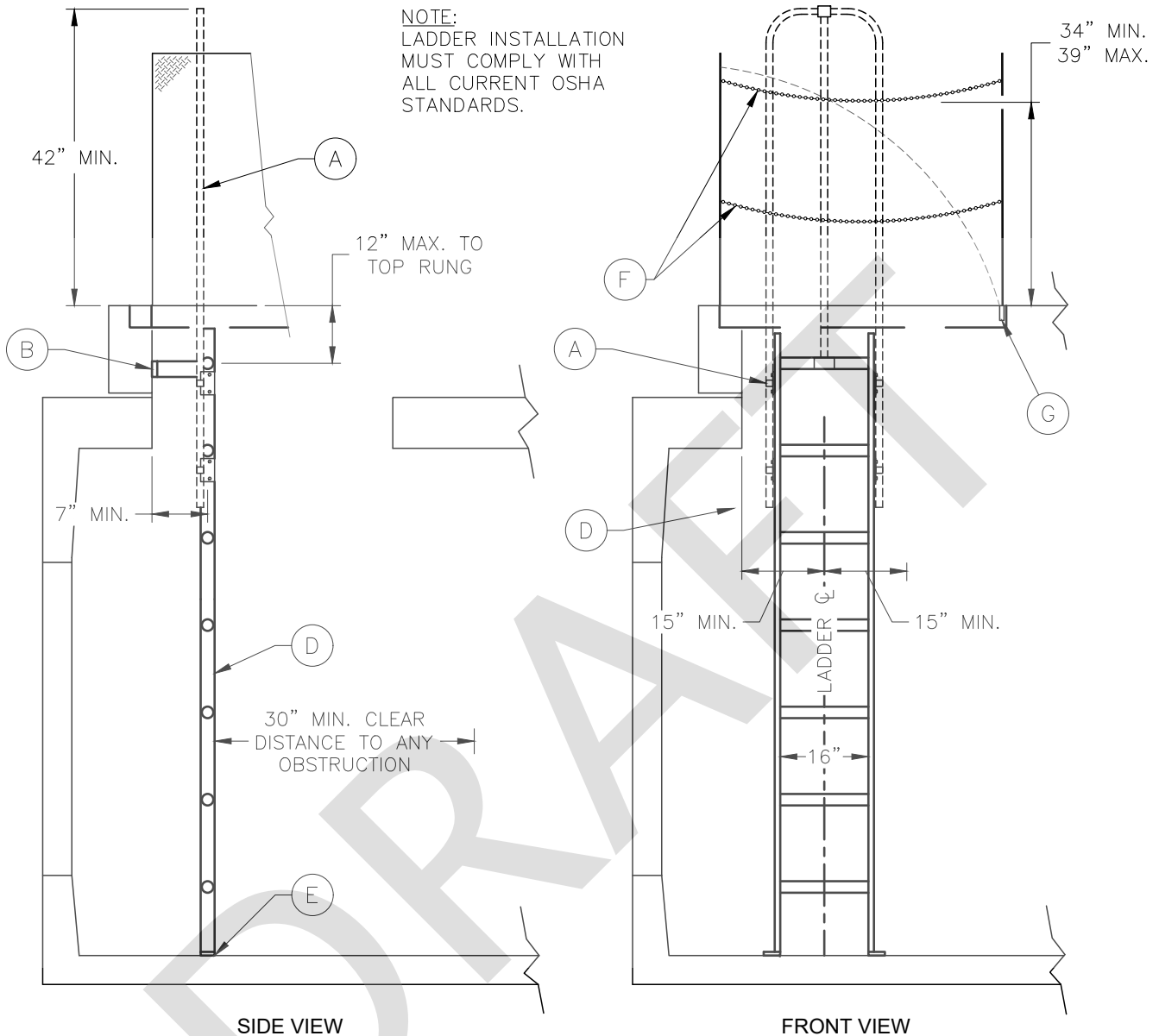

**KEYNOTES:**

- A. LADDER EXTENSION SHALL BE ALUMINUM AND EXTEND 42" ABOVE THE TOP OF THE VAULT OPENING. EXTENSION SHALL BE CPP COLUMBIA ALUMINUM LADDER EXTENSION OR APPROVED EQUAL.
- B. ATTACH LADDER SUPPORT TO INSIDE FACE OF VAULT COVER OPENING WITH STAINLESS STEEL HARDWARE AS SHOWN.  $\varnothing$  OF RUNG MUST BE SET 7" FROM FACE OF SURFACE BEHIND RUNG. LADDER SHALL BE ON THE SIDE ADJACENT TO THE DOOR HINGE.
- C. PROVIDE 15" MINIMUM LATERAL CLEARANCE ON EACH SIDE OF LADDER  $\varnothing$ .
- D. LADDER SHALL MEET THE REQUIREMENTS OF OSHA AND SHALL BE HOT-DIPPED GALVANIZED AFTER FABRICATION.
- E. LADDER SHALL BE ATTACHED TO FLOOR OF VAULT WITH STAINLESS STEEL HARDWARE PER MANUFACTURER RECOMMENDATIONS.
- F. STAINLESS STEEL SAFETY CHAINS SHALL BE ATTACHED TO LID. CHAIN POST MOUNTS ARE REQUIRED ON SINGLE DOOR VAULTS. CHAINS SHALL BE A MINIMUM OF 34" HIGH AT LOWEST POINT INCLUDING SAG, MAXIMUM OF 39", AND SHALL HAVE MID-SPAN CHAIN. CHAINS SHALL BE DETACHABLE ON LADDER SIDE OF VAULT AND POWDER COATED ORANGE FOR VISUAL AWARENESS.
- G. SINGLE DOOR VAULT FRAMES SHALL HAVE 2 POST MOUNTS ON THE INTERIOR OF THE FRAME FOR POST MOUNTED CHAINS.

N:\Standards\2024\Details\DWG\701\_Vault Ladder Installation.dwg, 6/13/2024 10:54:46 AM



**TUALATIN VALLEY  
WATER DISTRICT**

APPROVED BY  
PETER BOONE

DRAWING SCALE  
NONE

VAULT LADDER INSTALLATION

EFF. DATE 07/01/24

STANDARD DETAIL

701

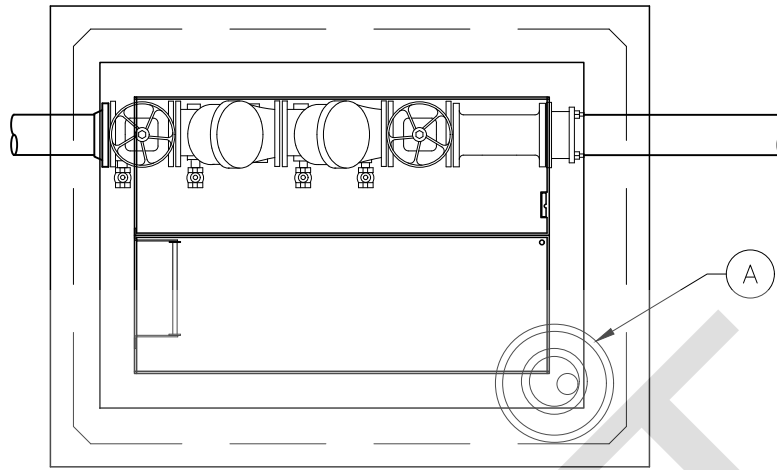

PLAN VIEW

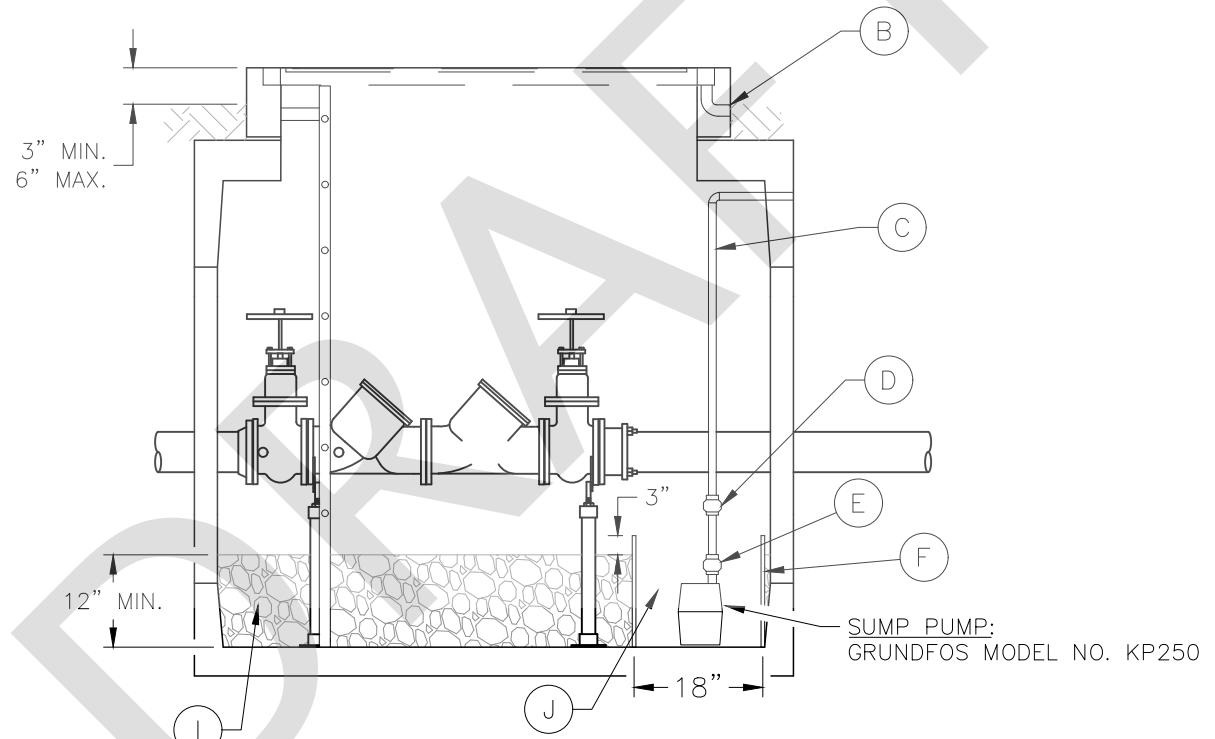

ELEVATION

SUMP PUMP:  
GRUNDFOS MODEL NO. KP250

**KEYNOTES:**

- A. LOCATE SUMP PUMP AWAY FROM PIPING AND DEVICES.
- B. DRAIN LID CHANNEL TO DAYLIGHT.
- C. 1-1/4" SCH 40 PVC SUMP PUMP DISCHARGE PIPING TO DISCHARGE LOCATION PER APPROVED DRAINAGE PLAN.
- D. ISOLATION BALL VALVE.
- E. INLINE CHECK VALVE.
- F. 18" MIN. DIAMETER PVC PIPE, PERFORATE ENTIRE PIPE AND WRAP PVC PIPE WITH MIRAFI FW402 FILTER FABRIC TO PREVENT INTRUSION OF ROCKS.
- G. 3" DRAIN TO CURB OR OTHER LOCATION WITH DISTRICT APPROVAL. NOT APPLICABLE IF SUMP PUMP IS INSTALLED.
- H. RODENT SCREEN. NOT APPLICABLE IF SUMP PUMP IS INSTALLED.
- I. 3/4"-1" CRUSHED ROCK FILL, NO FINES. CONTRACTOR SHALL PROTECT ALL PIPE, VALVES, METERS, DEVICES, ETC. WHILE PLACING ROCK.
- J. PROVIDE PERMANENT POWER SOURCE PER LOCAL ELECTRICAL CODES FOR SUMP PUMP. SECURE POWER CORD TO SUMP PUMP DISCHARGE PIPING WITH NYLON CABLE TIES.



**TUALATIN VALLEY**  
WATER DISTRICT

APPROVED BY  
PETER BOONE

DRAWING SCALE  
NONE

ELECTRIC SUMP PUMP  
INSTALLATION

EFF. DATE 07/01/24

STANDARD DETAIL

702

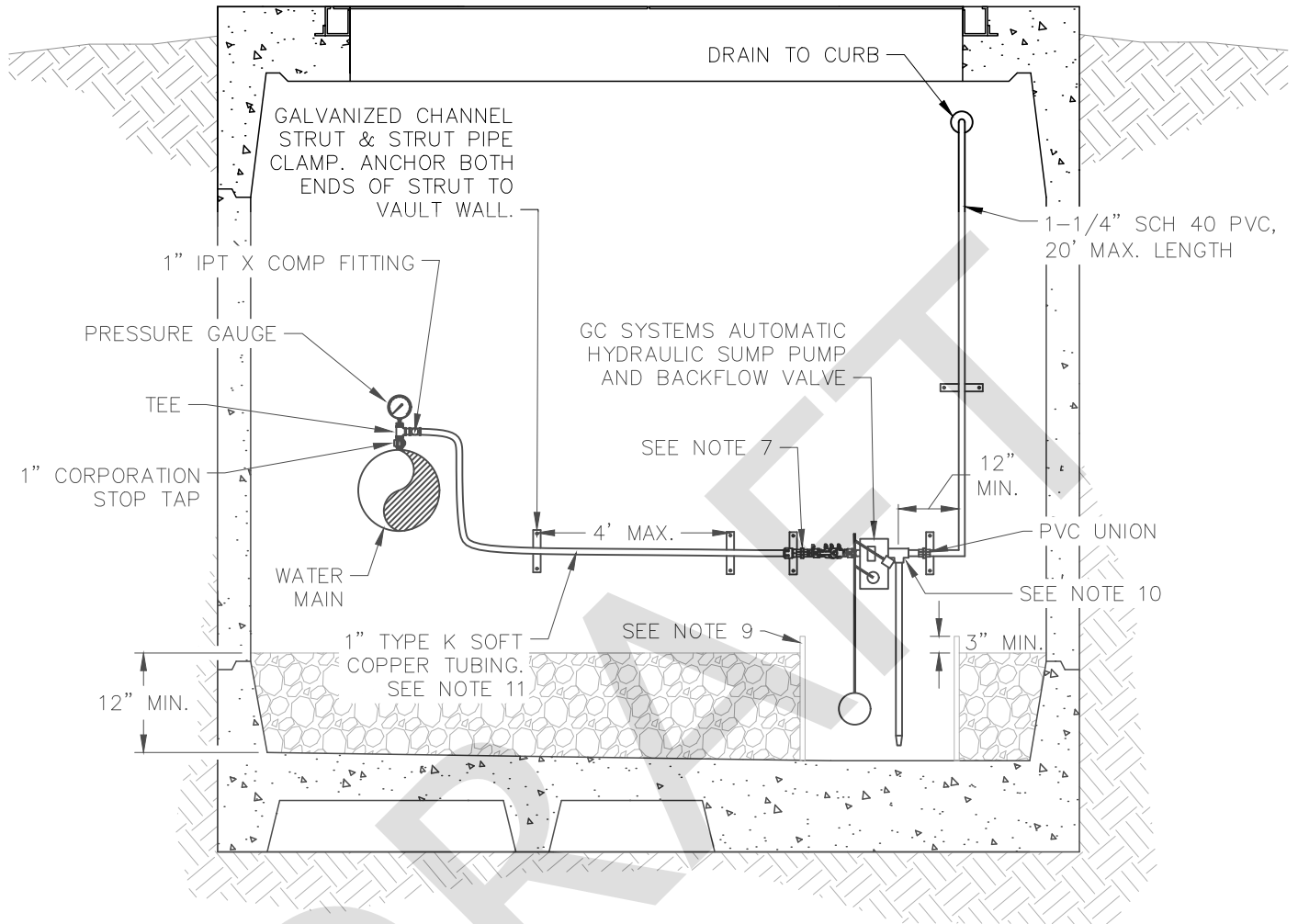

**GENERAL NOTES:**

- A. SHALL BE INSTALLED IN METER AND REGULATOR VAULTS ONLY WHERE PRESSURE IS 80 PSI OR LESS. IF PRESSURES EXCEED 80 PSI, INSTALL PRESSURE REDUCING VALVE PER PLUMBING CODE.
- B. ELECTRIC SUMP PUMPS MAY BE ALLOWED IF APPROVED BY A DISTRICT ENGINEER.

**NOTES:**

- 1. FOLLOW MANUFACTURERS INSTRUCTIONS FOR INSTALLATION OF SUMP PUMP ASSEMBLY.
- 2. INSTALL CHANNEL STRUT WITHIN 6" OF EACH END OF HYDRAULIC SUMP PUMP ASSEMBLY. STACK AND BOLT CHANNEL STRUT, PER STRUT MANUFACTURERS RECOMMENDATION, TO SPACE HYDRAULIC SUMP PUMP ASSEMBLY OFF OF VAULT WALL TO ALLOW 2" CLEARANCE IN ALL DIRECTIONS AROUND FLOAT.
- 3. LOCATE SUMP PUMP SUCTION INLET 3"-6" FROM VAULT FLOOR.
- 4. ALLOW ADEQUATE ROOM FOR TESTING OF DOUBLE CHECK VALVE ASSEMBLY.
- 5. THIS DETAIL IS SCHEMATIC IN NATURE, ACTUAL PIPING CONFIGURATION MUST BE APPROVED BY TWD INSPECTION STAFF PRIOR TO CONSTRUCTION.
- 6. TAP SHALL BE UPSTREAM OF METER.
- 7. CONNECT SUMP PUMP INSTALL 1" COPPER TO MIPT, 1" UNION, 1" X 3/4" BRASS BUSHING, AND 3/4" CLOSE BRASS NIPPLE.
- 8. REFER TO DETAIL 702 FOR ADDITIONAL INSTALLATION DETAILS NOT SHOWN.
- 9. 18" MIN. DIAMETER PVC PIPE, PERFORATE ENTIRE PIPE AND WRAP PVC PIPE WITH MIRAFI FW402 FILTER FABRIC TO PREVENT INTRUSION OF ROCKS.
- 10. PROVIDE SCHEDULE 40 PVC PIPING AND FITTINGS TO CONNECT BOTH THE SUCTION AND OUTLET OF THE SUMP PUMP.
- 11. BENDING OF COPPER TUBING IS PERMITTED, MIN. 12" RADIUS. KINKS IN TUBING ARE NOT ALLOWED.

N:\Standards\2024\Details\DWG\703\_Hydraulic Sump Pump Installation.dwg, 6/13/2024 10:55:13 AM



**TUALATIN VALLEY**  
WATER DISTRICT

APPROVED BY  
PETER BOONE

DRAWING SCALE  
NONE

HYDRAULIC SUMP PUMP  
INSTALLATION

EFF. DATE 07/01/24

STANDARD DETAIL

703



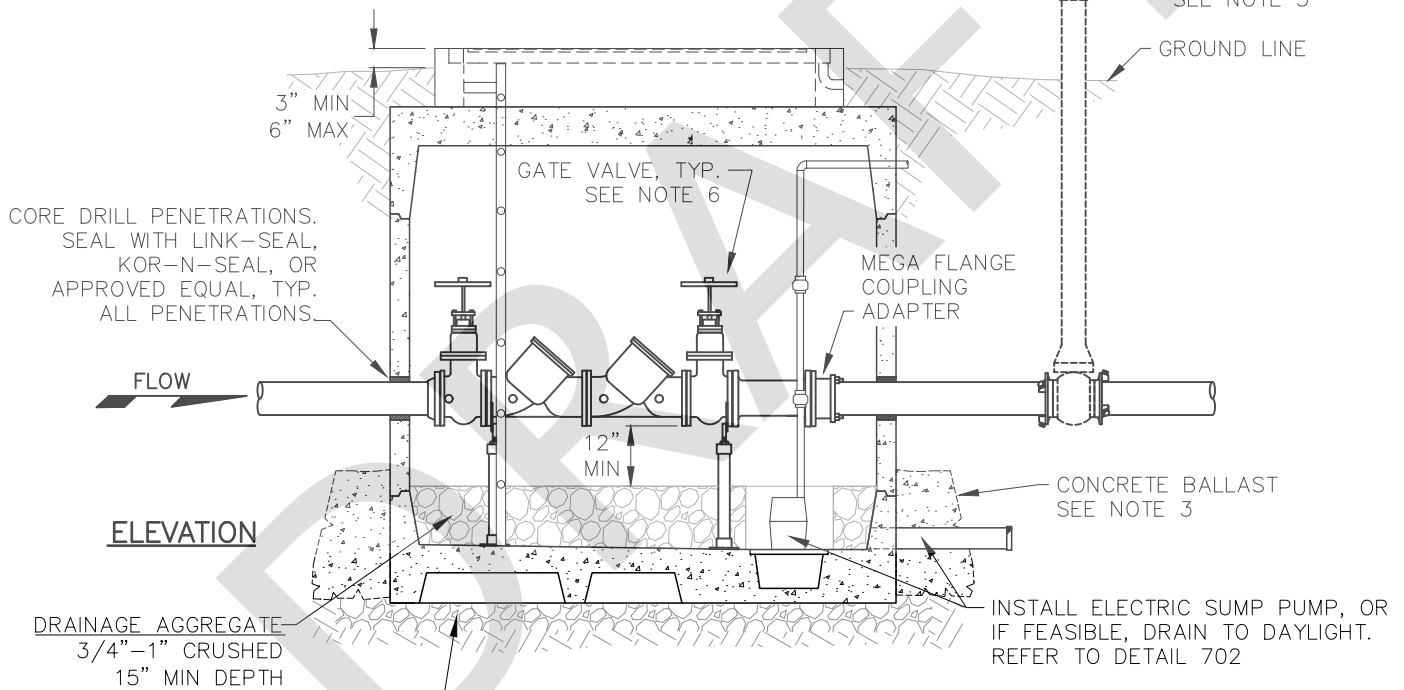
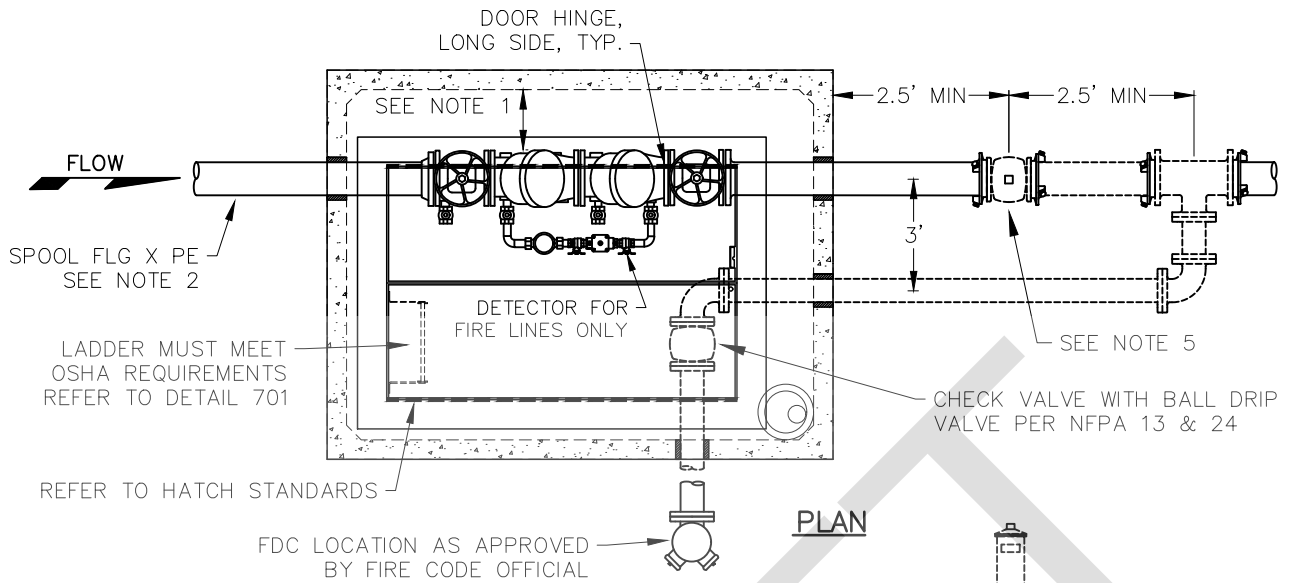

**NOTES:**

1. REFER TO OREGON ADMINISTRATIVE RULES FOR REQUIRED CLEARANCES. SEE OHA FOR LIST OF APPROVED ASSEMBLIES.
2. SEAL ALL OPENINGS IN VAULT WITH NON SHRINK GROUT.
3. INSTALL CONCRETE BALLAST 3 CU YDS MINIMUM AROUND BASE OF VAULT WHERE FLOODING OR HIGH GROUND WATER EXISTS, AS DETERMINED BY DISTRICT.
4. VAULTS AND LIDS ARE SIZED BASED ON DEVICE TEST PORTS ON LADDER SIDE OF VAULT. IF PORTS ARE ON OPPOSITE SIDE OF DEVICE, A LARGER VAULT MAY BE REQUIRED.
5. POST INDICATOR VALVE AND CHECK VALVE ARE REQUIRED ON PROJECTS WITHIN THE JURISDICTION OF HILLSBORO FIRE AND LOCATED AS APPROVED BY FIRE CODE OFFICIAL. CONSULT TVF&R FOR INSTANCES WHERE INSTALLATION IS REQUIRED WITHIN THEIR JURISDICTION.
6. FIRE LINE ASSEMBLY GATE VALVES OR OTHER ASSEMBLY APPLICATIONS MUST PROVIDE VISIBLE INDICATION OF OPEN/CLOSE. CONTRACTOR SHALL COORDINATE WITH LOCAL JURISDICTION(S) FOR REQUIREMENTS.

SIZE	UTILITY VAULT*	BILCO DOOR*
3	676-WA	JD-3ALH20 (48"X72")
4	676-WA	JD-3ALH20
6	676-WA	JD-3ALH20
8	687-WA	JD-3ALH20
10	810-LA	JD-3ALH20

\* "OR EQUAL"



**TUALATIN VALLEY  
WATER DISTRICT**

APPROVED BY  
PETER BOONE

DRAWING SCALE  
NONE

DOUBLE CHECK VALVE  
ASSEMBLY OR DOUBLE CHECK  
DETECTOR ASSEMBLY

EFF. DATE 07/01/24

STANDARD DETAIL

801

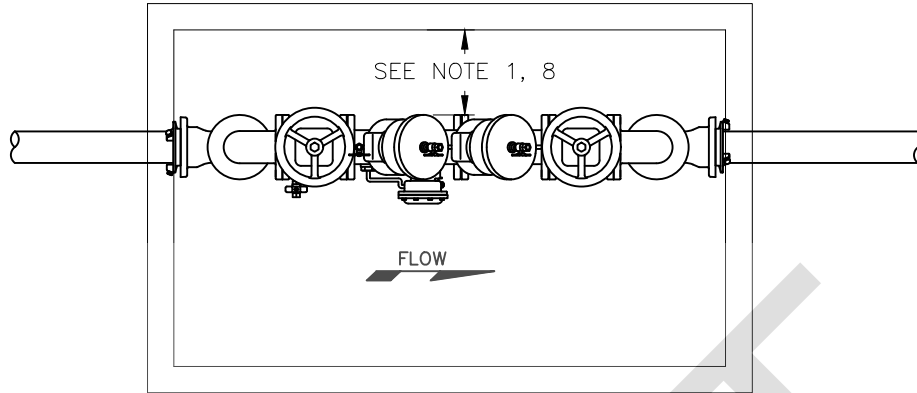

**PLAN**

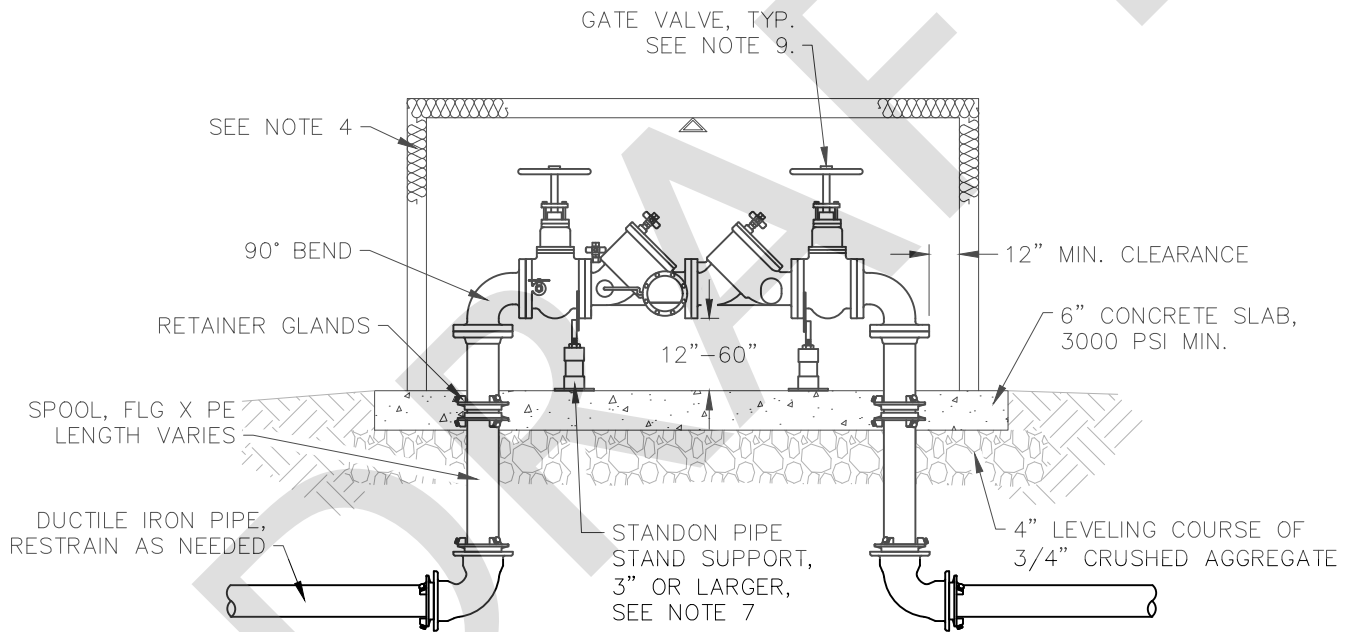

**ELEVATION**

**NOTES:**

1. REFER TO OREGON ADMINISTRATIVE RULES FOR ALL CLEARANCES AND OHA FOR LIST OF APPROVED ASSEMBLIES.
2. REDUCED PRESSURE BACKFLOW ASSEMBLY SHALL BE INSTALLED HORIZONTAL AND PLUMB. LOCATION SHALL BE APPROVED BY TVWD.
3. INSULATE BUILDING AND/OR HAVE A HEAT SOURCE TO KEEP ENCLOSURE AT 40°F (NFPA 13-4-5.4.1.1)
4. ENCLOSURE SHALL INCLUDE A BORE DRAIN TO DAYLIGHT CAPABLE OF DRAINING A FULL RELIEF VALVE DISCHARGE.
5. A DOOR OR OTHER APPROVED ACCESS SHALL BE PROVIDED.
6. ALL ASSEMBLIES 2-1/2" AND LARGER SHALL BE FLANGED.
7. ALL STRUCTURES TO COMPLY WITH LOCAL BUILDING CODES.
8. A REDUCED PRESSURE DETECTOR ASSEMBLY MAY REQUIRE ADDITIONAL CLEARANCES.
9. FIRE LINE ASSEMBLY GATE VALVES AND OTHER ASSEMBLY APPLICATIONS MUST PROVIDE VISIBLE INDICATION OF OPEN/CLOSE. CONTRACTOR SHALL COORDINATE WITH LOCAL JURISDICTION(S) FOR REQUIREMENTS.

N:\Standards\2024\Details\DWG\802\_Reduced Pressure Backflow Assembly (Above Ground).dwg, 6/13/2024 10:55:36 AM



**TUALATIN VALLEY  
WATER DISTRICT**

APPROVED BY  
PETER BOONE

DRAWING SCALE  
NONE

REDUCED PRESSURE BACKFLOW  
ASSEMBLY (ABOVE GROUND)

EFF. DATE 07/01/24

STANDARD DETAIL

802

N:\Standards\2024\Details\DWG\803\_Reduced Pressure Backflow Assembly (Vault).dwg, 6/13/2024 10:55:44 AM

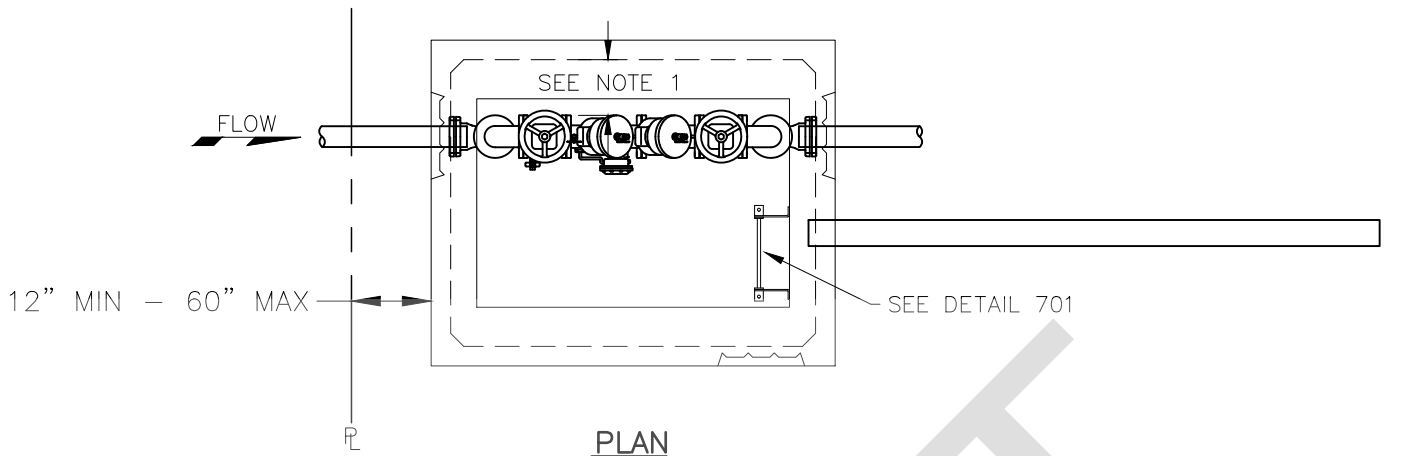

**PLAN**

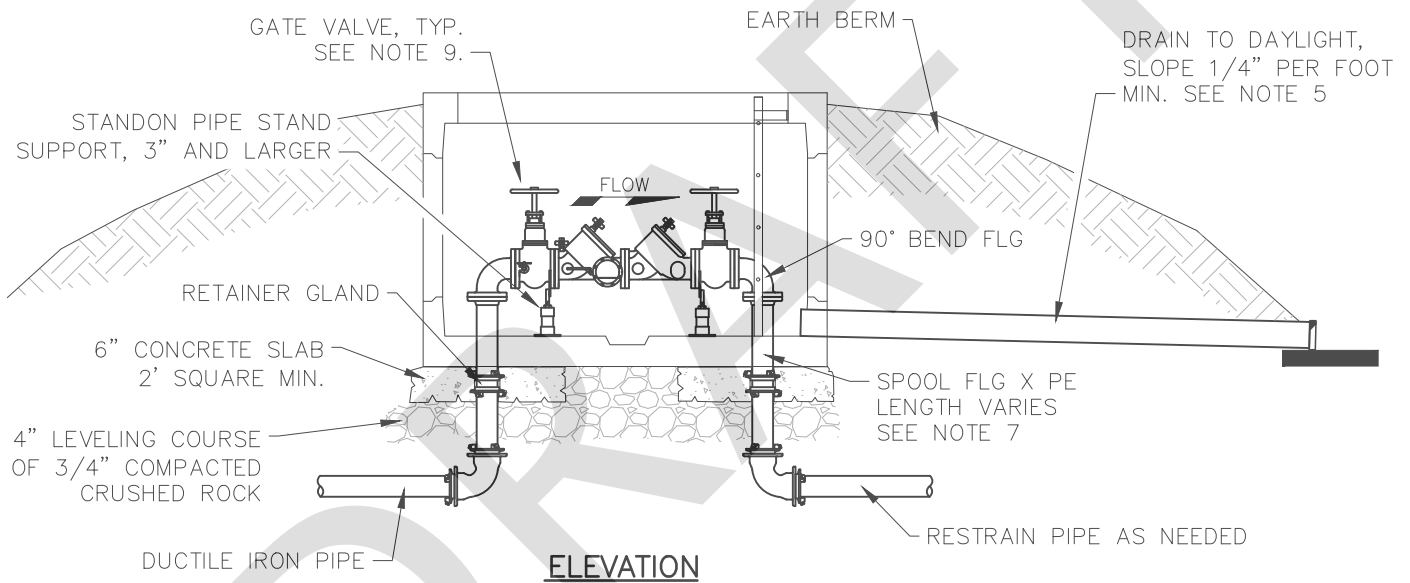

**ELEVATION**

**NOTES:**

1. REFER TO OREGON ADMINISTRATIVE RULES FOR REQUIRED CLEARANCES AND OHA FOR LIST OF APPROVED ASSEMBLIES.
2. REDUCED PRESSURE BACKFLOW ASSEMBLY SHALL BE INSTALLED IN A LOCATION APPROVED BY TVWD.
3. REDUCED PRESSURE BACKFLOW ASSEMBLY SHALL BE INSTALLED HORIZONTAL AND PLUMB.
4. VAULT TO BE INSULATED AND/OR HAVE A HEAT SOURCE TO KEEP ENCLOSURE AT 40°F MINIMUM (NFPA 13-4-5.4.1.1)
5. ENCLOSURE SHALL INCLUDE A BORE SIGHTED DRAIN TO DAYLIGHT CAPABLE OF DRAINING A FULL RELIEF VALVE DISCHARGE WITH RODENT SCREEN
6. ALL ASSEMBLIES 3" AND LARGER SHALL BE FLANGED.
7. ALL STRUCTURES TO COMPLY WITH LOCAL BUILDING CODES.
8. OPENINGS IN BOTTOM OF VAULT TO BE PRE-FORMED KNOCKOUTS.
9. FIRE LINE ASSEMBLY GATE VALVES AND OTHER ASSEMBLY APPLICATIONS MUST PROVIDE VISIBLE INDICATION OF OPEN/CLOSE. CONTRACTOR SHALL COORDINATE WITH LOCAL JURISDICTION(S) FOR REQUIREMENTS.

SIZE	UTILITY VAULT*	BILCO DOOR*
3	676-WA	JD-3ALH20 (48"X72")
4	676-WA	JD-3ALH20
6	676-WA	JD-3ALH20
8	687-WA	JD-3ALH20
10	810-LA	JD-3ALH20

\* "OR EQUAL"



**TUALATIN VALLEY  
WATER DISTRICT**

APPROVED BY  
PETER BOONE

DRAWING SCALE  
NONE

REDUCED PRESSURE  
BACKFLOW ASSEMBLY  
(IN VAULT)

EFF. DATE 07/01/24

STANDARD DETAIL

803

N:\Standards\2024\Details\DWG\804\_Minimum Protection for Filling Tanker Trucks.dwg, 6/13/2024 10:55:54 AM

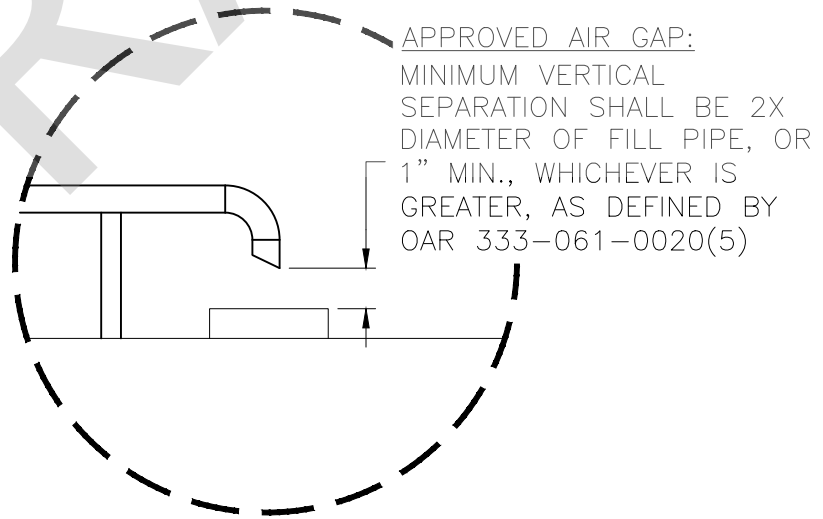
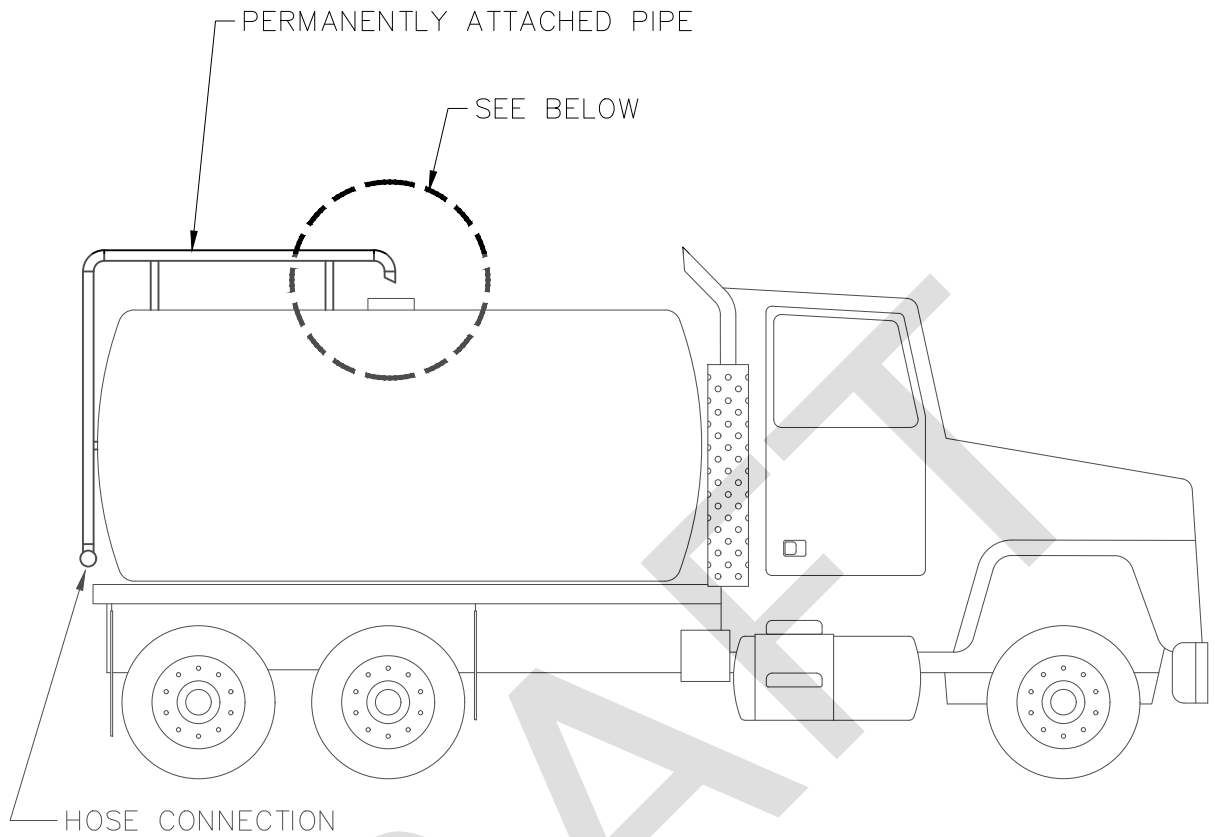

NOTES:

- 1. ALL BULK WATER ACCESS MUST BE INSPECTED, APPROVED, AND PERMITTED BY THE DISTRICT.



**TUALATIN VALLEY**  
WATER DISTRICT

APPROVED BY  
PETER BOONE

DRAWING SCALE  
NONE

MINIMUM PROTECTION FOR  
FILLING TANKER TRUCKS

EFF. DATE 07/01/24

STANDARD DETAIL

804